

BH LINE

ED. 16



Alusic

ALUMINIUM PROFILES AND ACCESSORIES

PROFILI IN ALLUMINIO E ACCESSORI
PERFILES DE ALUMINIO Y ACCESORIOS
PROFILÉS ET ACCESSOIRES EN ALUMINIUM
ALUMINIUM PROFILE UND ZUBEHÖR

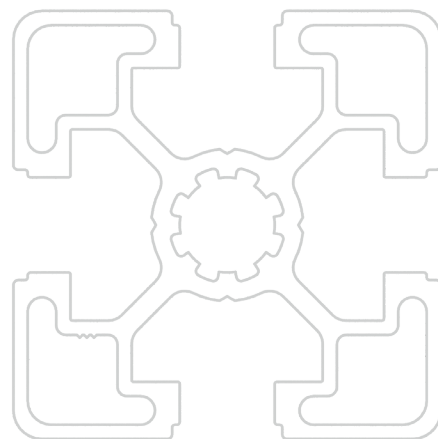



BH LINE



















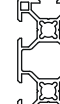





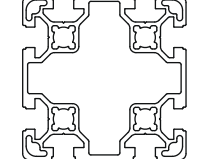







Alusic





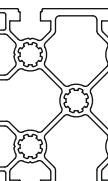
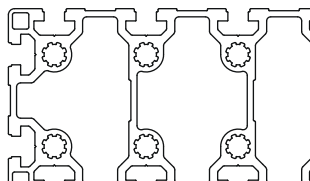
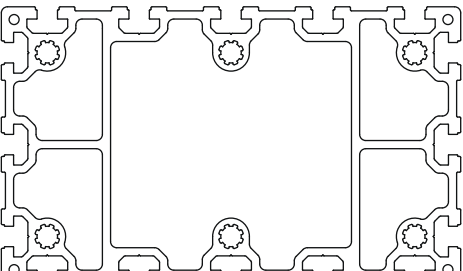

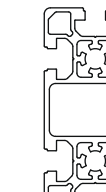
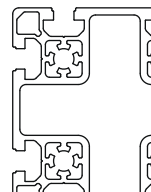
ALUMINIUM PROFILES AND ACCESSORIES

PROFILI IN ALLUMINIO E ACCESSORI
PERFILES DE ALUMINIO Y ACCESORIOS
PROFILÉS ET ACCESSOIRES EN ALUMINIUM
ALUMINIUM PROFILE UND ZUBEHÖR

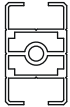
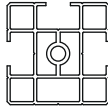
PROFILES / PROFILI / PERFILES / PROFILÉS / PROFILE

<p>BH 6 20</p>	 084.111.001 pag.17	 084.111.004 pag.17	 084.111.002 pag.18						
<p>BH 8 30</p>	 084.107.002 pag.23	 084.107.006 pag.23	 084.107.005 pag.25	 NEW 084.107.008 pag.24	 NEW 084.107.009 pag.24	 084.107.003 pag.25	 NEW 084.107.010 pag.26	 084.107.004 pag.26	 NEW 084.107.007 pag.27
<p>BH 10 40</p>	 084.113.001 pag.31	 084.113.002 pag.31	 084.113.003 pag.32						
<p>BH 10 45</p>	 084.105.004 pag.37	 084.105.015 pag.38	 084.105.010 pag.37	 084.105.011 pag.38	 084.105.012 pag.39	 084.105.018 pag.39	 084.105.007 pag.40	 084.105.008 pag.41	
<p>BH 10 45</p>	 084.105.006 pag.40	 084.105.019 pag.41	 084.105.005 pag.42	 084.105.017 pag.44	 084.105.016 pag.43	 084.105.014 pag.42			
<p>BH 10 45</p>	 084.105.009 pag.43	 084.105.013 pag.44	 084.105.020 pag.45						
<p>BH 10 50</p>	 084.109.001 pag.49	 084.109.002 pag.49	 084.109.003 pag.50						

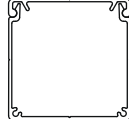
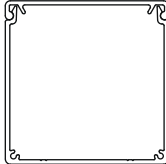
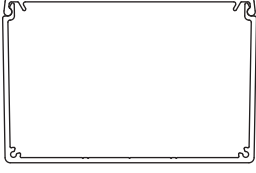
PROFILES / PROFILI / PERFILES / PROFILÉS / PROFILE

<p>FENCES Recinzioni Cerchiamientos Grilles Umzäunungen</p>	 084.104.003 pag.55	 084.112.001 pag.55	 084.112.002 pag.56			
<p>SPECIALS Speciali Especiales Grilles Besondere</p>	 084.101.092 084.101.093 pag.59	 084.101.097 084.101.098 pag.59	 084.101.053 084.101.054 pag.60	 084.101.078 084.101.075 pag.60	 084.101.055 084.101.056 pag.61	 084.101.099 084.101.100 pag.61
 084.101.065 pag.62						

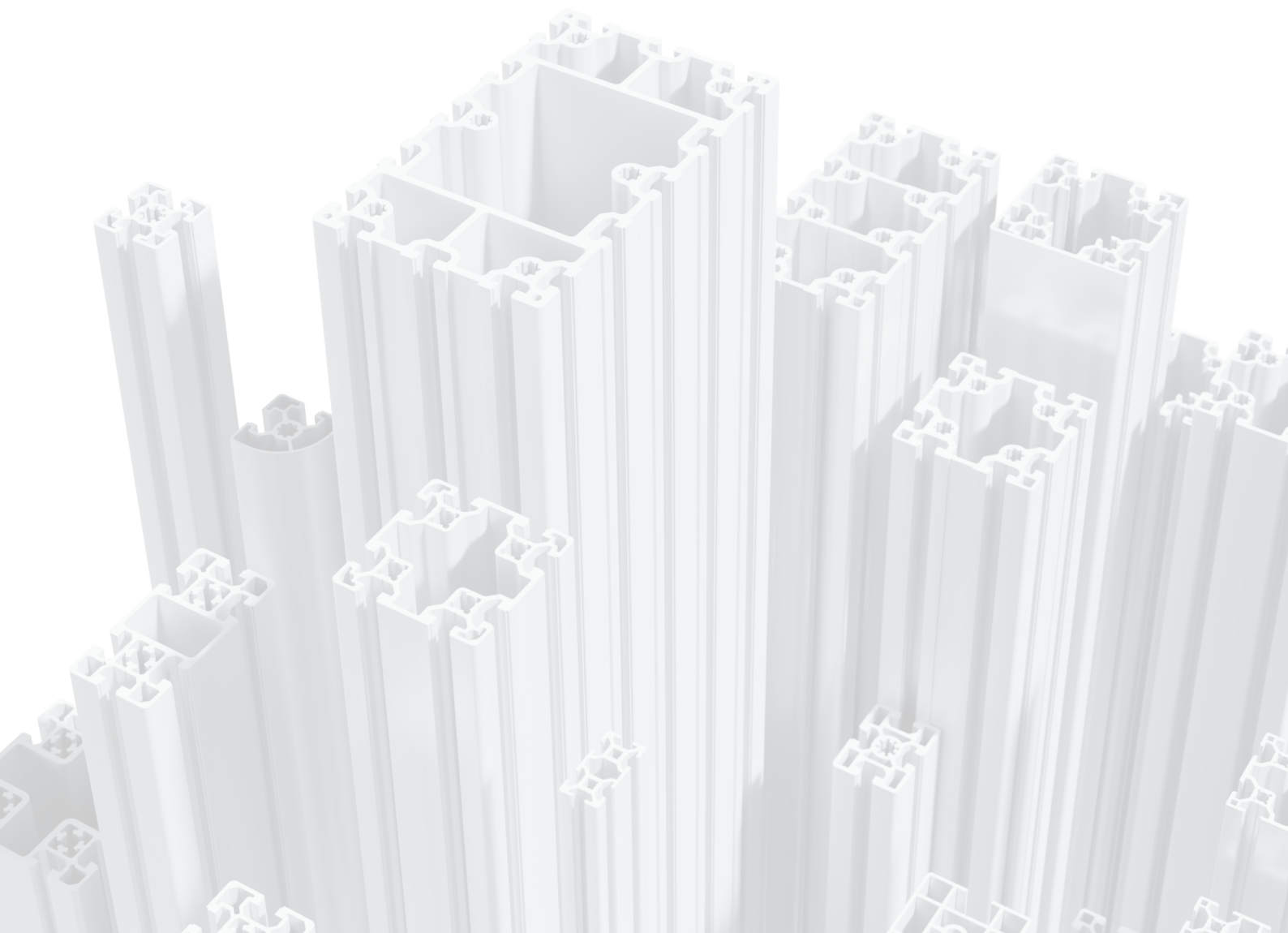

ACCESSORIES / ACCESSORI / ACCESORIOS / ACCESSOIRES / ZUBEHÖR

COVER PROFILES / CHIUDICAVA / PERFILES DE RECUBRIMIENTO / PROFILÉS DE FERMETURE / ABDECKPROFILE

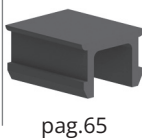

SCREWS / VITERIA / TORNILLOS / VIS / SCHRAUBEN

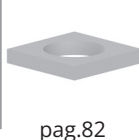

CONNECTORS / GIUNTI / JUNTAS / ÉLÉMENTS DE LIAISON / BEFESTIGUNGSELEMENTE

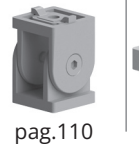

ANGLES / ANGOLARI / ANGULARES / EQUERRES DE FIXACION / WINKEL



FEET/ PIEDI / PIES / PIEDS / STELLFÜSSE

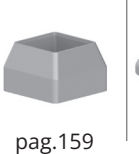

CASTORS / RUOTE / RUEDAS / ROULETTES / ROLLEN



PANELS / PANNELLI / PANELES / PANNEAUX / PLATTEN

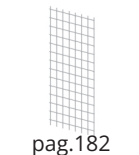
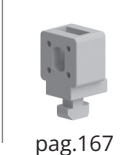

ACCESSORIES / ACCESSORI / ACCESORIOS / ACCESSOIRES / ZUBEHÖR

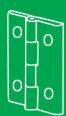
HINGES / CERNIERE / BISAGRAS / CHARNIÈRES / SCHARNIERE

pag.183



pag.193



pag.195

HANDLES / MANIGLIE / MANIJAS / POIGNÉES / GRIFFE

pag.200



pag.203

ACCESSORIES FOR DOORS / ACCESSORI PER SPORTELLI / ACCESORIOS PARA PUERTAS / ACCESSOIRES POUR PORTES / ZUBEHÖR FÜR TORE

pag.210



pag.222



pag.225

LED LIGHTING DEVICES / SISTEMI LED / SISTEMAS DE ILUMINACIÓN POR LED / APPAREILS D'ÉCLAIRAGE À LED / LED-LEISTEN



pag.231



pag.226

TOOLS / UTENSILI / HERRAMIENTAS / OUTILS / WERKZEUGE

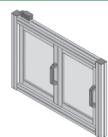
pag.236

ASSEMBLY SYSTEMS / SISTEMI DI MONTAGGIO / SISTEMAS DE MONTAJE / SISTÈMES DE MONTAGE / MONTAGESYSTEME

pag.242

EN

Alusic is synonymous with a huge range of accessories for extruded aluminium profiles. The company uses cutting-edge technology, both for 2D/3D modeling and rapid prototyping using FDM (Fused Deposition Modeling).

The company's continual expansion of its product range means that our catalogue contains components produced using a wide range of technologies. Our website, www.alusic.com, is updated on a daily basis in order to keep our customers informed on all our news and innovations.

Alusic is ISO 9001:2008 and EN1090 certified: these strict certifications are a testament to our continuous commitment to guaranteeing our customers the highest standards of quality.

IT

Alusic significa una vasta gamma di accessori per profili in alluminio estruso. L'azienda si avvale di software all'avanguardia sia per quanto riguarda la modellazione 2D/3D che per la prototipazione rapida con tecnologia FDM (Fused Deposition Modeling).

Il continuo ampliamento della gamma di prodotti fa sì che all'interno del catalogo vi siano i componenti realizzati attraverso le più disparate tecnologie. Al fine di mantenere il cliente sempre informato sulle novità il sito www.alusic.com viene aggiornato quotidianamente.

Alusic inoltre dispone della certificazione ISO9001:2008 e della severa EN1090 a testimonianza del continuo impegno per garantire ai suoi clienti un elevato standard di qualità.

ES

Alusic ofrece una extensa gama de accesorios para perfiles de aluminio extruido. La empresa utiliza softwares de vanguardia tanto para el modelado 2D/3D como para la creación rápida de prototipos con tecnología FDM (Fused Deposition Modeling).

La continua ampliación de la gama de productos hace que en el catálogo puedan encontrarse componentes fabricados con las más diversas tecnologías. Para mantener a los clientes siempre informados acerca de las novedades, la página Web www.alusic.com se actualiza diariamente.

Además, Alusic dispone de la certificación ISO 9001:2008 y de la estricta EN 1090, lo que demuestra el continuo esfuerzo para garantizar a sus clientes un elevado estándar de calidad.

FR

Alusic est synonyme de vaste gamme d'accessoires pour profilés en aluminium extrudé. L'entreprise dispose d'un logiciel d'avant-garde utilisé pour la modélisation 2D/3D et pour la réalisation rapide de prototypes à l'aide de la technologie FDM (Fused Deposition Modeling).

La constante extension de la gamme de produits est telle que le catalogue contient des composants réalisés en recourant aux technologies les plus diverses. Pour que le client soit toujours informé des nouveautés, le site www.alusic.com est quotidiennement actualisé.

De plus, Alusic dispose de la certification ISO 9001:2008 et respecte la très sévère norme EN 1090, attestant ainsi les constants efforts déployés afin de garantir aux clients de hauts standards de qualité.

DE

Alusic bietet eine große Auswahl an Zubehör für stranggepresste Aluminiumprofile. Das Unternehmen nutzt hochmoderne Software – sowohl für die 2D-/3D-Modellierung als auch für das Rapid Prototyping mit FDM-Technologie (Fused Deposition Modeling).

Dank der kontinuierlichen Erweiterung der Produktpalette finden sich im Katalog Komponenten, die durch unterschiedlichste Technologien geschaffen werden. Damit der Kunde stets über alle Neuigkeiten informiert ist, wird die Website www.alusic.com täglich aktualisiert.

Des Weiteren verfügt Alusic über eine Zertifizierung nach ISO 9001:2008 und nach der strengen EN 1090 – Zeugnis des stetigen Einsatzes des Unternehmens, um seinen Kunden einen hohen Qualitätsstandard zu garantieren.

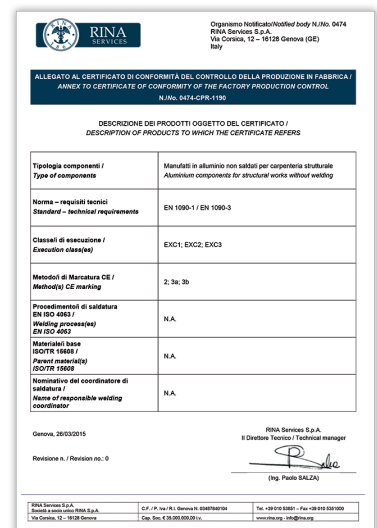

PROFILE FASTENING

FISSAGGIO DEI PROFILI / FIJACIÓN DE LOS PERFILES / FIXATION DES PROFILÉS / BEFESTIGUNG DER PROFILE

The choice of fasteners for the various profiles is very important, and there are numerous different types:

La scelta del fissaggio tra i vari profili è molto importante e ne esistono di diversi tipi:

La elección de la fijación entre los distintos perfiles es muy importante y existen diferentes tipos:

Le choix des fixations entre les différents profilés revêt une grande importance; il en existe de différents types:

Die Wahl der Befestigungsart zwischen den unterschiedlichen Profilen ist äußerst wichtig und es gibt verschiedene Möglichkeiten:

1

Fastening with screw in slot. Quick, simple installation.

Fissaggio con vite in cava. Installazione semplice e veloce.

Fijación con tornillo en la ranura. Instalación sencilla y rápida.

Fixation à vis dans la rainure. Installation simple et rapide.

Befestigung mit Schraube in Nut. Einfache und schnelle Installation.

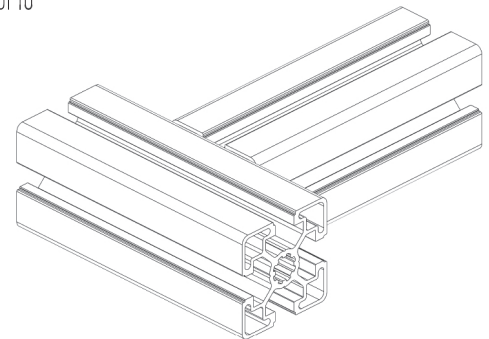
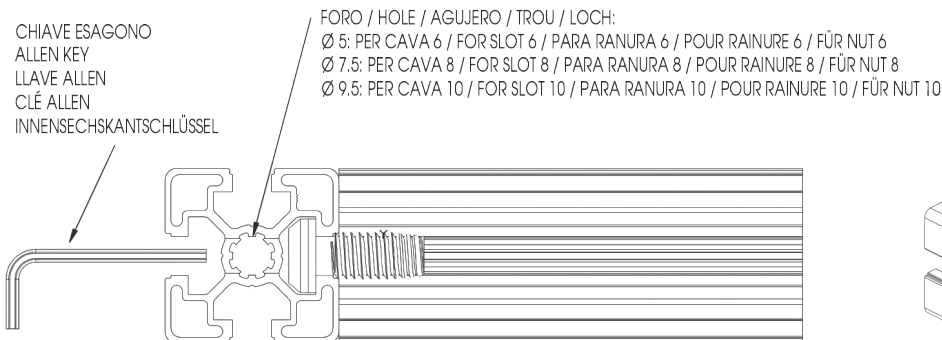

2

Fastening with through screw or counterbore.

Secure and simple, this solution ensures that parts will not slip if the screws come loose.

Fissaggio con vite passante o lamatura.

Semplice e sicuro, garantisce l'antiscivolo dei particolari in caso di allentamento delle viti.

Fijación con tornillo pasante o avellanado.

Sencillo y seguro, garantiza que los componentes no se desacoplen en caso de aflojamiento de los tornillos.

Fixation à vis traversante ou lamage.

Simple et sûre, cette fixation prévient le déboîtement des pièces en cas de desserrage des vis.

Befestigung mit Durchsteckschraube oder Senkung.

Einfach und sicher, garantiert die Sicherung der Teile im Falle eines Lösens der Schrauben.

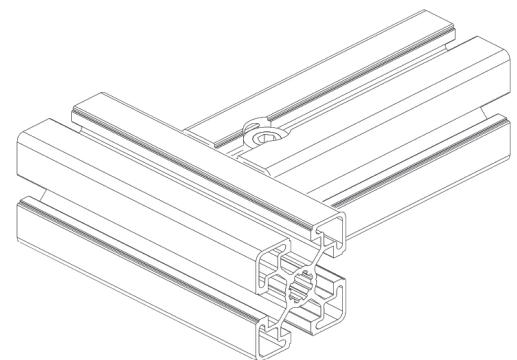
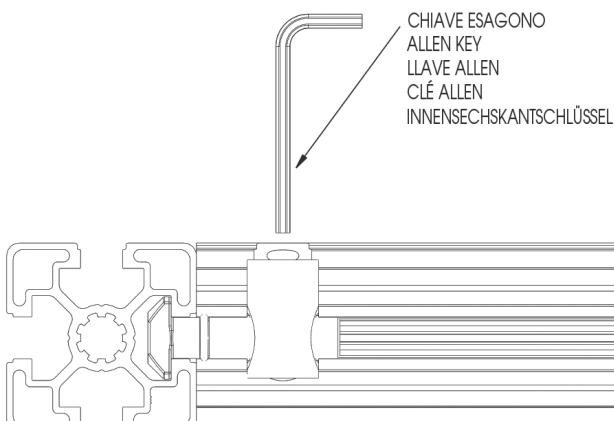

3

Fastening with angles or connectors. Wide possibility for adjustment and ease of installation.

Fissaggio con angolari o connettori. Grande possibilità di regolazione e facilità di montaggio.

Fijación con escuadras o acopladores. Gran posibilidad de ajuste y facilidad de montaje.

Fixation à cornières ou connecteurs. Grande possibilité de réglage et facilité de montage.

Befestigung mit Winkelverbindern oder Verbindungsstücken. Zahlreiche Einstellmöglichkeiten und einfache Montage.

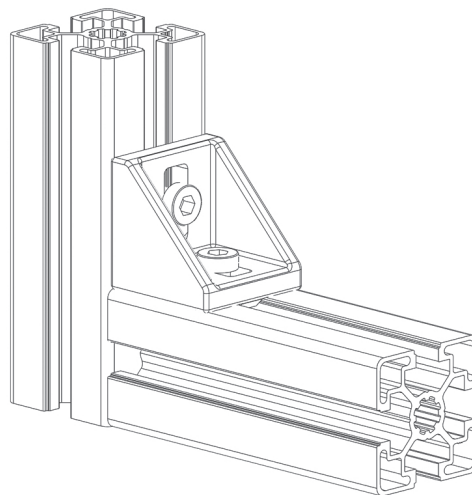
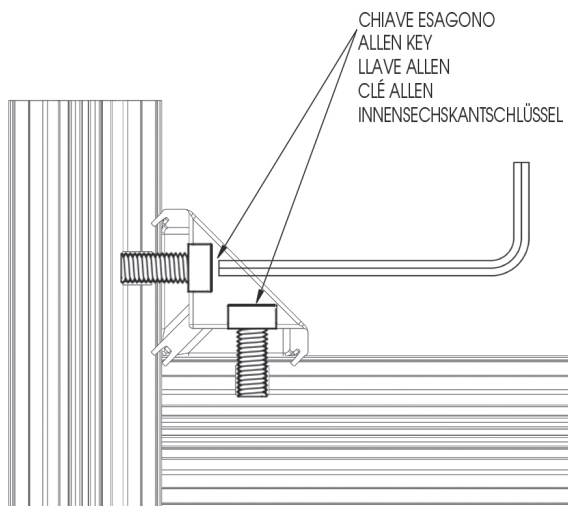

THREADING OF PROFILES

FILETTATURA DEI PROFILI / ROSCADO DE LOS PERFILES / FILETAGE DES PROFILÉS / GEWINDE DER PROFILE

When making the threads, we recommend that you follow the depths (L [mm]) given in the following table:

Nella realizzazione delle filettature si consiglia di rispettare le profondità (L [mm]) riportate nella tabella seguente:

A la hora de realizar los roscados, se aconseja respetar las profundidades (L [mm]) indicadas en la siguiente tabla:

Pour la réalisation des filetages, il est recommandé de respecter les profondeurs (L (mm)) indiquées dans le tableau ci-après:

Bei der Ausführung der Gewinde sollten die in der folgenden Tabelle angegebenen Tiefen (L [mm]) eingehalten werden:

Slot / Cava / Ranura / Rainure / Nut	M	L (mm)
6	6	15
8	8	25
10	12	30

The maximum screw tightening torque (C MAX) suggested for the assembly of Alusic components (unless otherwise specified or particular applications to be assessed on a case-by-case basis) is as follows:

Le coppie massime di serraggio (C MAX) consigliate per le viti per i vari componenti del catalogo Alusic (salvo diverse specifiche o applicazioni particolari valutabili caso per caso) sono le seguenti:

Los pares de apriete máximos (C MAX) recomendados para los tornillos destinados al montaje de los distintos componentes del catálogo Alusic (salvo que se especifique otra cosa o para aplicaciones especiales, que deben evaluarse caso por caso) son los siguientes:

Les couples de serrage maximal des vis (C MAX) recommandés pour les vis des différents composants du catalogue Alusic (sauf indication contraire ou applications particulières à évaluer au cas par cas) sont les suivants:

Die maximalen Anzugsmomente (C MAX), die für die Schrauben für die verschiedenen Komponenten des Alusic-Katalogs empfohlen werden (sofern nicht anders angegeben oder bei besonderen Anwendungen, die für den jeweiligen Fall zu bewerten sind), sind folgende:

Slot / Cava / Ranura / Rainure / Nut	M	C MAX (N/m)
6	6	10
8	8	20
10	12	35

LOAD/BENDING DIAGRAM

DIAGRAMMA CARICO/INFLESSIONE / DIAGRAMA CARGA/INFLEXIÓN / DIAGRAMME CHARGE/FLEXION / LAST-/BIEGEDIAGRAMM

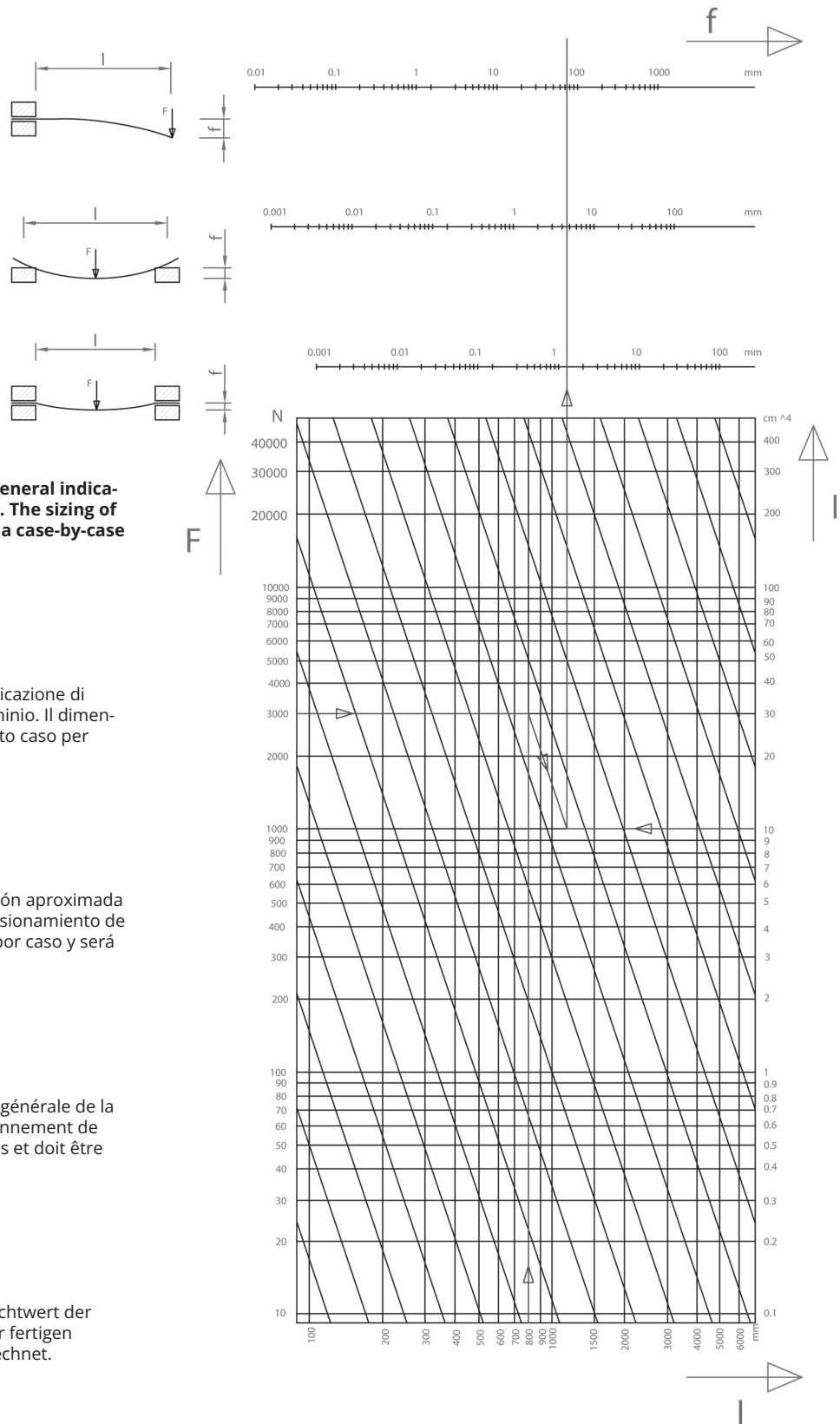

The diagram shown to the side provides a general indication of the bending of an aluminium profile. The sizing of the finished structure will be calculated on a case-by-case basis, and is the customer's responsibility.

Example:

Load: 3000 N

Moment of inertia: 10 cm^4

Distance between supports: 800 mm

Il diagramma riportato a fianco fornisce un'indicazione di massima della flessione di un profilato in alluminio. Il dimensionamento della struttura finita andrà calcolato caso per caso e sarà a cura del cliente.

Esempio:

Carico: 3000N

Momento di inerzia: 10 cm^4

Distanza appoggi: 800 mm

El diagrama contiguo proporciona una indicación aproximada de la flexión de un perfil de aluminio. El dimensionamiento de la estructura acabada deberá calcularse caso por caso y será a cargo del cliente.

Ejemplo:

Carga: 3000 N

Momento de inerzia: 10 cm^4

Distancia apoyos: 800 mm

Le diagramme ci-contre fournit une indication générale de la flexion d'un profilé en aluminium. Le dimensionnement de la structure finie doit être calculé au cas par cas et doit être fourni par le client.

Exemple:

Charge: 3000 N

Moment d'inertie: 10 cm^4

Espacement des supports: 800 mm

Das nebenstehende Diagramm liefert einen Richtwert der Biegung eines Aluminiumprofils. Die Größe der fertigen Struktur wird von Fall zu Fall vom Kunden berechnet.

Beispiel:

Last: 3000 N

Trägheitsmoment: 10 cm^4

Abstand zwischen den Stützen: 800 mm

SYMBOLS / SIMBOLI / SÍMBOLOS / SYMBOLES / SYMBOLE



Product for series 20 6 BH slot profiles

Prodotto per profili serie 20 cava 6 BH
 Producto para perfiles con ranura 6 BH serie 20
 Produit pour profilés rainure 6 BH série 20
 Produkt für Profile 6 BH Nut Reihe 20



Product for series 30 8 BH slot profiles

Prodotto per profili serie 30 cava 8 BH
 Producto para perfiles con ranura 8 BH serie 30
 Produit pour profilés rainure 8 BH série 30
 Produkt für Profile 8 BH Nut 8 Reihe 30



Product for series 40 10 BH slot profiles

Prodotto per profili serie 40 cava 10 BH
 Producto para perfiles con ranura 10 BH serie 40
 Produit pour profilés rainure 10 BH série 40
 Produkt für Profile 10 BH Nut Reihe 40



Product for series 45 10 BH slot profiles

Prodotto per profili serie 45 cava 10 BH
 Producto para perfiles ranura 10 BH serie 45
 Produit pour profilés rainure 10 BH série 45
 Produkt für Profile 10 BH Nut Reihe 45



Product for series 50 10 BH slot profiles

Prodotto per profili serie 50 cava 10 BH
 Producto para perfiles ranura 10 BH serie 50
 Produit pour profilés rainure 10 BH série 50
 Produkt für Profile 10 BH Nut Reihe 50



Box

Scatola
 Caja
 Boîte
 Schachtel



Load

Portata
 Carga
 Charge
 Tragkraft

STAINLESS STEEL

Stainless steel product

Prodotto in inox
 Producto de acero inoxidable
 Produit en acier inoxydad
 Produkt aus rostfreiem Stahl

ITALIAN PATENT

Patented product

Prodotto brevettato
 Producto patentado
 Produit breveté
 Patentiertes Produkt

PATENT

NEW

New product

Prodotto nuovo
 Nuevo producto
 Nouveau produit
 Neues Produkt

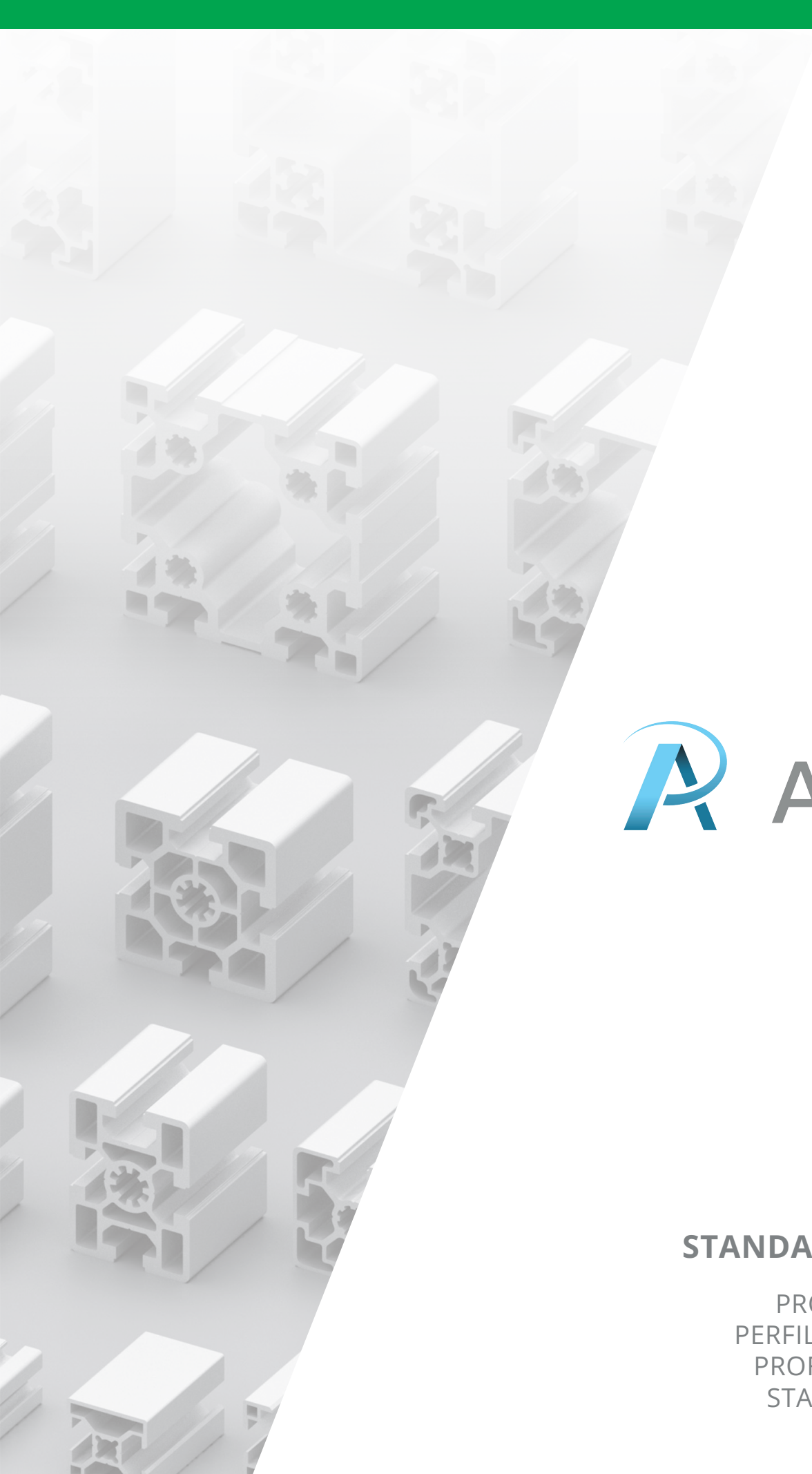

Alusic

STANDARD PROFILES

PROFILI STANDARD
PERFILES ESTÁNDARES
PROFILÉS STANDARD
STANDARD-PROFILE

ALUSIC STRUCTURAL PROFILES

PROFILI STRUTTURALI ALUSIC / PERFILES ESTRUCTURALES ALUSIC / PROFILÉS STRUCTURELS ALUSIC / KONSTRUKTIONSPROFILE ALUSIC

EN

All profiles in the Alusic catalog are made through the extrusion of aluminum alloy, 60% of which comes from recycled sources. The aluminium used is supplied as T5/T6 temper (cooled from hot working/solution heat treated and artificially aged). The bars are normally supplied with a 12 µm anodising treatment (on request, most profiles can also be supplied as mill finish). The tolerances applied when extruding the profiles follow EN 12020-2.

IT

Tutti i profili del catalogo Alusic sono realizzati per estrusione di lega di alluminio proveniente al 60% da fonti riciclate. Lo stato metallurgico di fornitura è T5/T6 (solubilizzato, temprato e invecchiato artificialmente). Le barre sono normalmente fornite anodizzate con profondità di trattamento in classe 12 µm (a richiesta la maggior parte dei profili può essere fornita grezza). Le tolleranze generali seguite per l'estrusione dei profili seguono la norma UNI-EN 12020-2.

ES

Todos los perfiles del catálogo de Alusic se fabrican mediante la extrusión de aleación de aluminio, el 60% de la cual proviene de fuentes recicladas. El estado metalúrgico en que se suministran es T5/T6 (solubilizado, templado y envejecido artificialmente). Las barras normalmente se suministran anodizadas, con una profundidad de tratamiento de 12 µm (bajo solicitud, la mayor parte de los perfiles puede suministrarse en bruto). Las tolerancias generales conseguidas mediante la extrusión de los perfiles son acordes a la norma UNI-EN 12020-2.

FR

Tous les profils du catalogue Alusic sont réalisés par extrusion d'alliage d'aluminium provenant à 60% de sources recyclées. L'état métallurgique de fourniture est l'état T5/T6 (solubilisé, trempé et vieilli artificiellement). Les barres sont fournies anodisées avec une profondeur de traitement en classe 12 µm (sur demande, la plupart des profilés peuvent être fournis bruts). Les tolérances générales appliquées à l'extrusion des profilés respectent la norme UNI-EN 12020-2.

DE

Alle Profile im Alusic-Katalog werden durch Extrusion von Aluminiumlegierungen hergestellt, wobei 60% aus recycelten Quellen stammen. Der metallurgische Lieferzustand ist T5/T6 (lösungsgeglüht, abgeschreckt aus der Warmumformungstemperatur und warmausgehärtet). Normalerweise werden die Stangen dem Eloxalverfahren unterzogen und haben eine 12 µm dicke Schutzschicht (auf Anfrage sind die meisten der Profile auch ohne Eloxierung erhältlich). Für die Strangpressung der Profile wurden die allgemeinen Toleranzen der Norm UNI EN 12020-2 eingehalten.

CHEMICAL COMPOSITION OF ALLOYS

COMPOSIZIONE DELLE LEGHE / COMPOSICIÓN QUÍMICA DE LAS ALEACIONES

COMPOSITION CHIMIQUE DES ALLIAGES / CHEMISCHE ZUSAMMENSETZUNG DER LEGIERUNGEN

EN-AW	Cu	Fe	Mn	Mg	Si	Zn	Cr	Ti	Al
6060	0.10	0.1 - 0.3	0.10	0.35 - 0.6	0.3 - 0.6	0.15	0.05	0.10	dal 98% al 99%
6063	0.10	0.35	0.10	0.45 - 0.9	0.2 - 0.6	0.10	0.10	0.10	dal 97,5% al 98,5%

MECHANICAL PROPERTIES

CARATTERISTICHE MECCANICHE / CARACTERÍSTICAS MECÁNICAS

CARACTÉRISTIQUES MÉCANIQUES / MECHANISCHE EIGENSCHAFTEN

EN-AW	Rm (N/mm ²)	Rp0,2 (N/mm ²)	A (%)	HB
6060	190	150	8	70
6063	215	170	8	75

PHYSICAL PROPERTIES

CARATTERISTICHE FISICHE / CARACTERÍSTICAS FÍSICAS

CARACTÉRISTIQUES PHYSIQUES / PHYSIKALISCHE EIGENSCHAFTEN

E [N/mm ²]	69000
ρ [Ω mm/m]	0.033
λ W/mK	210
T _m (C°)	615 - 655
α (K ⁻¹)	25X10 ⁻⁶



Alusic

PROFILES SERIES 20 SLOT 6 BH

PROFILI SERIE 20 CAVA 6 BH
PERFILES SERIE 20 RANURA 6 BH
PROFILÉS SÉRIE 20 RAINURE 6 BH
PROFILE REIHE 20 NUT 6 BH

EN Alusic series 20 profiles, featuring a 6 mm fastening T-slot, are one of the lightest ranges in the Alusic catalogue.

This range can be fastened with M6 hardware using suitable accessories, or by M6 threading at the ends of the bars. Nuts are available with M4 and M5 threads; they can be inserted at any point in the slot, even following initial assembly of the structure.

IT I profili Alusic serie 20, dotati di una cava di fissaggio da 6 mm a "T", rappresentano una delle linee più leggere del catalogo.

La serie permette il fissaggio con viti M6 tramite gli opportuni accessori di fissaggio o tramite filettatura M6 alle estremità delle barre. Per quanto riguarda i dadi sono disponibili con filetti M4 e M5; possono essere inseriti in qualunque punto della cava anche successivamente al primo montaggio della struttura.

ES Los perfiles Alusic serie 20, dotados de una ranura de fijación de 6 mm en "T", conforman una de las líneas más ligeras del catálogo.

La serie permite la fijación con tornillos M6 mediante los correspondientes accesorios de fijación o mediante roscado M6 en los extremos de las barras. En lo que respecta a las tuercas, están disponibles con roscas M4 y M5; pueden insertarse en cualquier punto de la ranura, incluso con posterioridad al primer montaje de la estructura.

FR Les profilés Alusic série 20, dotés d'une rainure de fixation de 6 mm en « T », constituent une des lignes les plus légères du catalogue.

La série permet la fixation à l'aide de vis M6, au moyen des accessoires de fixation appropriés ou par filetage M6 à l'extrémité des barres. Concernant les écrous, ils sont disponibles avec filetages M4 et M5 ; ils peuvent être introduits à hauteur de tout point de la rainure, y compris après le premier montage de la structure.

DE Die Alusic-Profilen der Reihe 20 mit T-förmiger Befestigungsnut zu 6 mm stellen eine der leichtesten Produktlinien des Katalogs dar.

Die Reihe ermöglicht die Befestigung mit Schrauben M6 durch das geeignete Befestigungszubehör oder durch Gewinde M6 an den Stangenenden. Die Muttern sind mit Gewinden M4 und M5 erhältlich; sie können an jeder Stelle der Nut eingesetzt werden, auch nach der Erstmontage der Struktur.

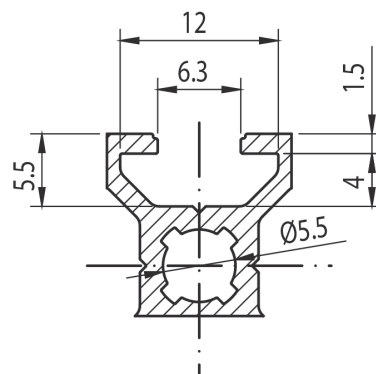

20x20

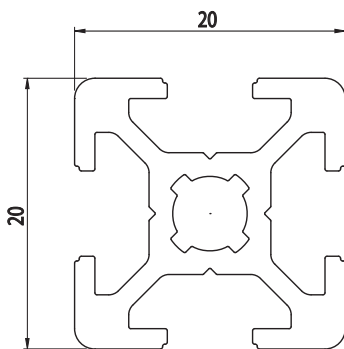

Cod	lx cm ⁴	ly cm ⁴	wx cm ³	wy cm ³	mm ²	Kg/m
084.111.001	0,67	0,67	0,67	0,67	164,83	0,45

Anodised aluminium
 Alluminio anodizzato
 Aluminio anodizado
 Aluminium anodisé
 Eloxiertes Aluminium
L=6040 mm

Natural colour
 Colore naturale
 Color natural
 Couleur naturelle
 Natürliche Farbe

Tappo - Cap - Tapòn - Embout - Abdeckkappe			
Cod	Mat	g	Col
084.201.061	PA	2	■
084.201.061G	PA	2	■

20x20

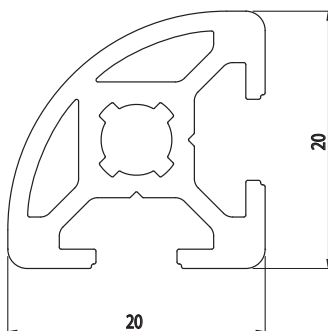
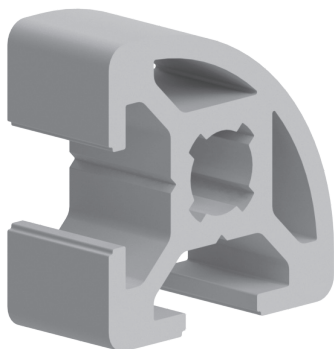

Cod	lx cm ⁴	ly cm ⁴	wx cm ³	wy cm ³	mm ²	Kg/m
084.111.004	0,44	0,73	0,42	0,69	163,58	0,44

Anodised aluminium
 Alluminio anodizzato
 Aluminio anodizado
 Aluminium anodisé
 Eloxiertes Aluminium
L=6040 mm

Natural colour
 Colore naturale
 Color natural
 Couleur naturelle
 Natürliche Farbe

Tappo - Cap - Tapòn - Embout - Abdeckkappe			
Cod	Mat	g	Col
084.201.075	PA	3	■
084.201.075G	PA	3	■

20x40

BH
20

Cod	lx cm ⁴	ly cm ⁴	wx cm ³	wy cm ³	mm ²	Kg/m
084.111.002	4,64	1,20	1,32	1,20	289,70	0,78

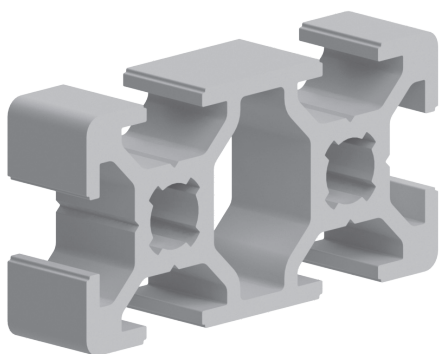

Anodised aluminium



Alluminio anodizzato
Aluminio anodizado
Aluminium anodisé
Eloxiertes Aluminium

L=6040 mm

Natural colour

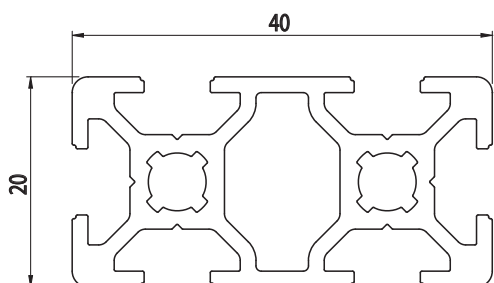
Colore naturale
Color natural
Couleur naturelle
Natürliche Farbe

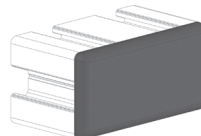

Tappo - Cap - Tapón - Embout - Abdeckkappe			
			
Cod	Mat	g	Col
084.201.062	PA	3	■
084.201.062G	PA	3	■

ASSEMBLY SYSTEMS
SISTEMI DI MONTAGGIO
SISTEMAS DE MONTAJE
SISTÈMES DE MONTAGE
MONTAGESYSTEME

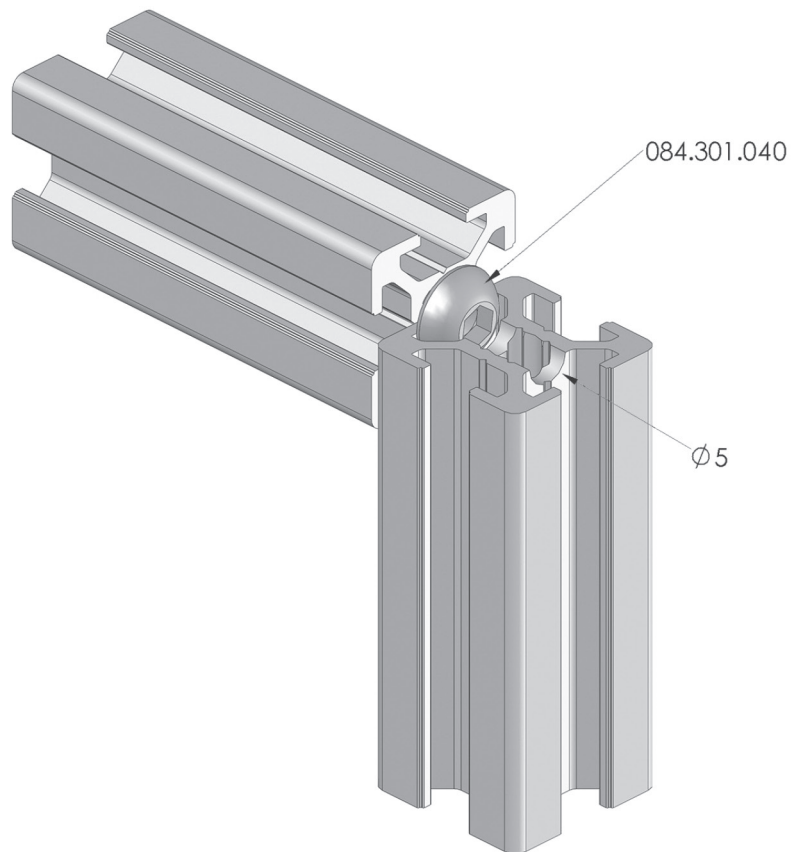





PROFILES SERIES 30 SLOT 8 BH

PROFILI SERIE 30 CAVA 8 BH
PERFILES SERIE 30 RANURA 8 BH
PROFILÉS SÉRIE 30 RAINURE 8 BH
PROFILE REIHE 30 NUT 8 BH

EN

Alusic series 30 profiles, featuring an 8 mm fastening T-slot, are one of the ranges with the best strength-weight ratios. This range can be fastened with M8 hardware using suitable accessories, or by M8 threading at the ends of the bars. Nuts are available with M4, M5 and M6 threads; they can be inserted at any point in the slot, even following initial assembly of the structure.

IT

I profili Alusic serie 30, dotati di una cava di fissaggio da 8 mm a "T", rappresentano una delle linee con il migliore rapporto peso/resistenza meccanica. La serie permette il fissaggio con viti M8 tramite gli opportuni accessori di fissaggio o tramite filettatura M8 alle estremità delle barre. Per quanto riguarda i dadi sono disponibili con filetti M4, M5 e M6; possono essere inseriti in qualunque punto della cava anche successivamente al primo montaggio della struttura.

ES

Los perfiles Alusic serie 30, dotados de una ranura de fijación de 8 mm en "T", conforman una de las líneas con la mejor relación peso-resistencia mecánica. La serie permite la fijación con tornillos M8 mediante los correspondientes accesorios de fijación o mediante roscado M8 en los extremos de las barras. En lo que respecta a las tuercas, están disponibles con roscas M4, M5 y M6; pueden insertarse en cualquier punto de la ranura, incluso con posterioridad al primer montaje de la estructura.

FR

Les profilés Alusic série 30, dotés d'une rainure de fixation de 8 mm en « T », représentent l'une des lignes offrant le meilleur rapport poids/résistance mécanique. La série permet la fixation à l'aide de vis M8, au moyen des accessoires de fixation appropriés ou par filetage M8 à l'extrémité des barres. Concernant les écrous, ils sont disponibles avec filetages M4, M5 et M6 ; ils peuvent être introduits à hauteur de tout point de la rainure, y compris après le premier montage de la structure.

DE

Die Alusic-Profile der Reihe 30 mit T-förmiger Befestigungsnut zu 8 mm stellen eine der Produktlinien mit dem besten Verhältnis zwischen Gewicht und mechanischer Festigkeit dar. Die Reihe ermöglicht die Befestigung mit Schrauben M8 durch das geeignete Befestigungszubehör oder durch Gewinde M8 an den Stangenenden. Die Muttern sind mit Gewinden M4, M5 und M6 erhältlich; sie können an jeder Stelle der Nut auch nach der Erstmontage der Struktur eingesetzt werden.

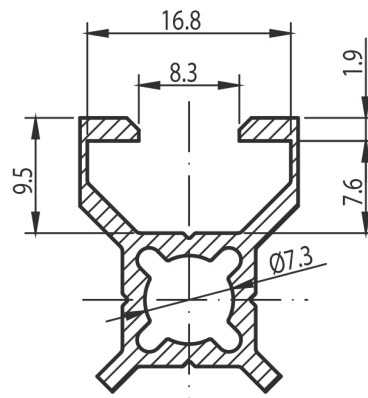

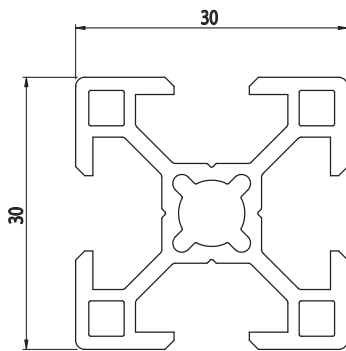
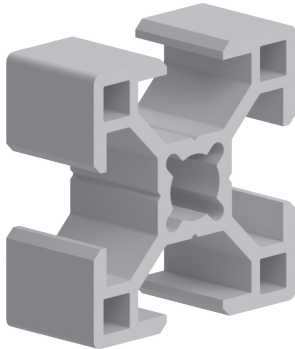

30x30BH
8
30

Cod	lx cm ⁴	ly cm ⁴	wx cm ³	wy cm ³	mm ²	Kg/m
084.107.002	2,60	2,60	1,73	1,73	273	0,74

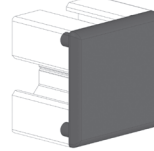

Anodised aluminium
 Alluminio anodizzato
 Aluminio anodizado
 Aluminium anodisé
 Eloxiertes Aluminium
L=6040 mm

Natural colour
 Colore naturale
 Color natural
 Couleur naturelle
 Natürliche Farbe

Tappo - Cap - Tapón - Embout - Abdeckkappe			
			
Cod	Mat	g	Col
084.201.041	PA	3	■
084.201.041G	PA	3	■

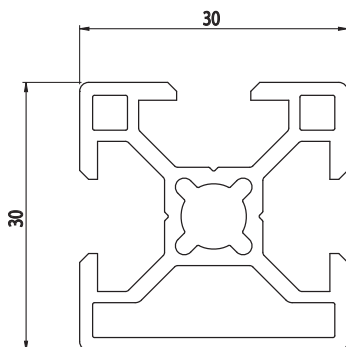
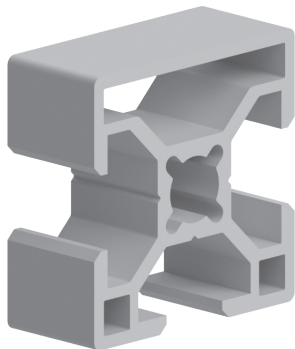

30x30BH
8
30

Cod	lx cm ⁴	ly cm ⁴	wx cm ³	wy cm ³	mm ²	Kg/m
084.107.006	2,54	2,68	1,70	1,77	275	0,74

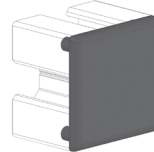

Anodised aluminium
 Alluminio anodizzato
 Aluminio anodizado
 Aluminium anodisé
 Eloxiertes Aluminium
L=6040 mm

Natural colour
 Colore naturale
 Color natural
 Couleur naturelle
 Natürliche Farbe

Tappo - Cap - Tapón - Embout - Abdeckkappe			
			
Cod	Mat	g	Col
084.201.041	PA	3	■
084.201.041G	PA	3	■

30x30

NEW

BH
30

Cod	lx cm ⁴	ly cm ⁴	wx cm ³	wy cm ³	mm2	Kg/m
084.107.008	2,73	2,63	1,82	1,75	282	0,76

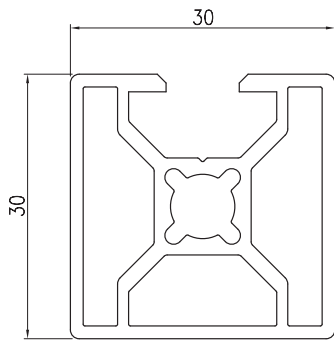
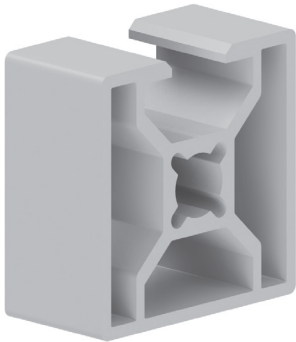

Anodised aluminium
Alluminio anodizzato
Aluminio anodizado
Aluminium anodisé
Eloxiertes Aluminium
L=6040 mm

Natural colour
Colore naturale
Color natural
Couleur naturelle
Natürliche Farbe

Tappo - Cap - Tapón - Embout - Abdeckkappe			
Cod	Mat	g	Col
084.201.041	PA	3	■
084.201.041G	PA	3	■

30x30

NEW

BH
30

Cod	lx cm ⁴	ly cm ⁴	wx cm ³	wy cm ³	mm2	Kg/m
084.107.009	2,54	2,54	1,69	1,69	262	0,71

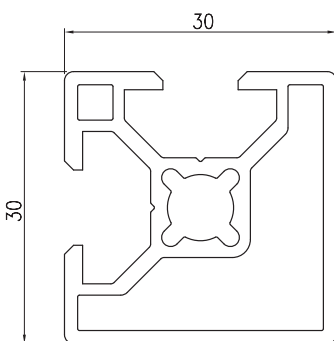
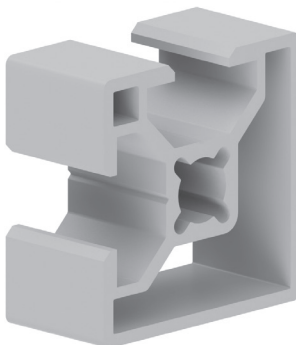

Anodised aluminium
Alluminio anodizzato
Aluminio anodizado
Aluminium anodisé
Eloxiertes Aluminium
L=6040 mm

Natural colour
Colore naturale
Color natural
Couleur naturelle
Natürliche Farbe

Tappo - Cap - Tapón - Embout - Abdeckkappe			
Cod	Mat	g	Col
084.201.041	PA	3	■
084.201.041G	PA	3	■

30x30

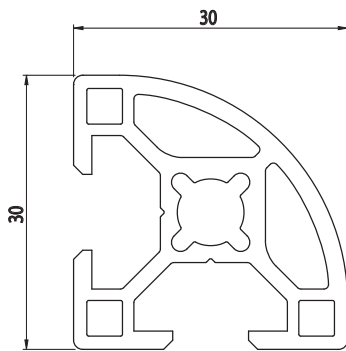
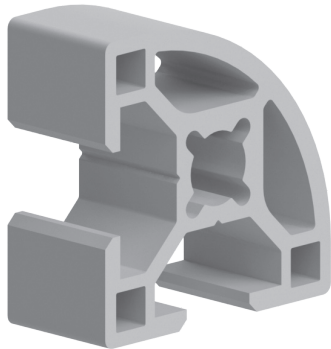

Cod	lx cm ⁴	ly cm ⁴	wx cm ³	wy cm ³	mm ²	Kg/m
084.107.005	1,84	2,88	1,23	1,92	289,13	0,78

Anodised aluminium
 Alluminio anodizzato
 Aluminio anodizado
 Aluminium anodisé
 Eloxiertes Aluminium
L=6040 mm

Natural colour
 Colore naturale
 Color natural
 Couleur naturelle
 Natürliche Farbe

Tappo - Cap - Tapón - Embout - Abdeckkappe			
Cod	Mat	g	Col
084.201.063	PA	3	■
084.201.063G	PA	3	■

30x60

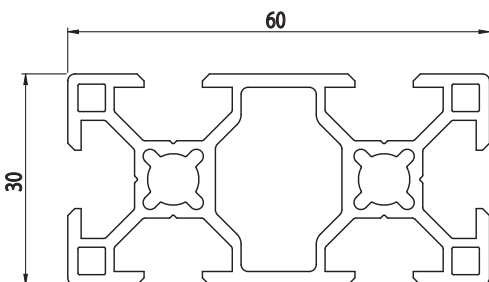
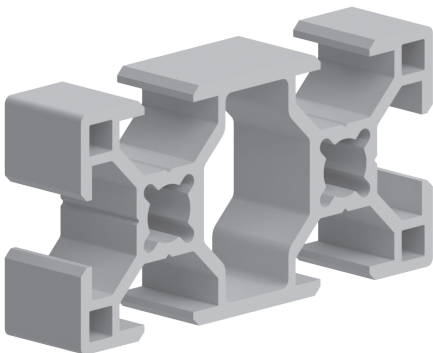

Cod	lx cm ⁴	ly cm ⁴	wx cm ³	wy cm ³	mm ²	Kg/m
084.107.003	17,54	4,57	5,85	3,05	487	1,32

Anodised aluminium
 Alluminio anodizzato
 Aluminio anodizado
 Aluminium anodisé
 Eloxiertes Aluminium
L=6040 mm

Natural colour
 Colore naturale
 Color natural
 Couleur naturelle
 Natürliche Farbe

Tappo - Cap - Tapón - Embout - Abdeckkappe			
Cod	Mat	g	Col
084.201.042	PA	6	■
084.201.042G	PA	6	■

30x60

NEW

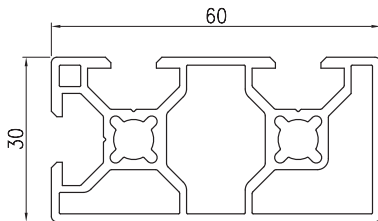
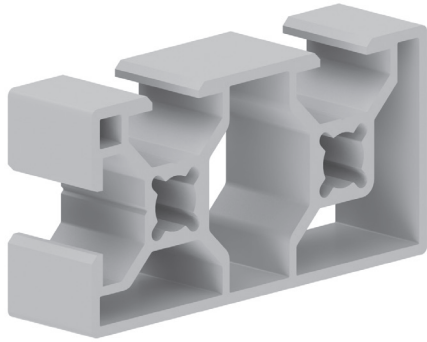

BH
8 5
30



Cod	lx cm ⁴	ly cm ⁴	wx cm ³	wy cm ³	mm ²	Kg/m
084.107.010	17,03	4,72	5,68	3,15	476	1,29

Anodised aluminium
Alluminio anodizzato
Aluminio anodizado
Aluminium anodisé
Eloxiertes Aluminium
L=6040 mm

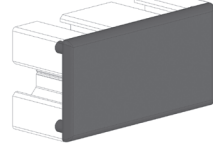
Natural colour
Colore naturale
Color natural
Couleur naturelle
Natürliche Farbe

Tappo - Cap - Tapòn - Embout - Abdeckkappe			
			
Cod	Mat	g	Col
084.201.042	PA	6	■
084.201.042G	PA	6	■

60x60

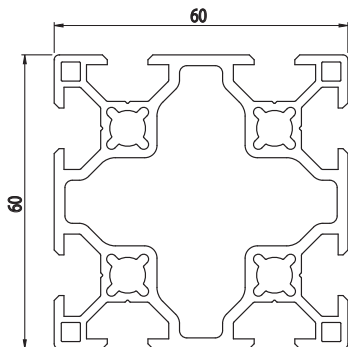
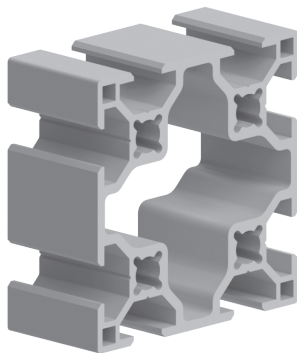

BH
8 5
30



Cod	lx cm ⁴	ly cm ⁴	wx cm ³	wy cm ³	mm ²	Kg/m
084.107.004	33,79	33,79	11,26	11,26	856,60	2,30

Anodised aluminium
Alluminio anodizzato
Aluminio anodizado
Aluminium anodisé
Eloxiertes Aluminium
L=6040 mm

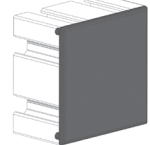
Natural colour
Colore naturale
Color natural
Couleur naturelle
Natürliche Farbe

Tappo - Cap - Tapòn - Embout - Abdeckkappe			
			
Cod	Mat	g	Col
084.201.057	PA	12	■
084.201.057G	PA	12	■

60x60**NEW**

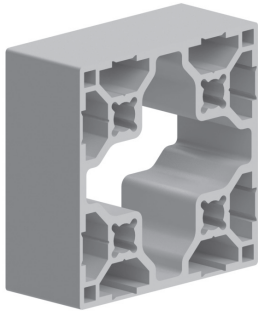

Cod	lx cm ⁴	ly cm ⁴	wx cm ³	wy cm ³	mm ²	Kg/m
084.107.007	37,49	37,49	12,49	12,49	923,6	2,5

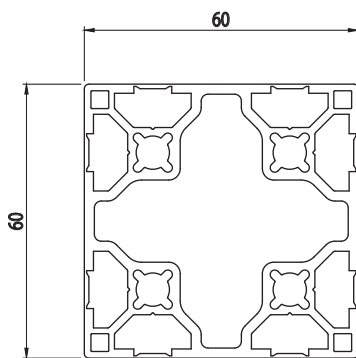

Anodised aluminium
 Alluminio anodizzato
 Aluminio anodizado
 Aluminium anodisé
 Eloxiertes Aluminium
L=6040 mm

Natural colour
 Colore naturale
 Color natural
 Couleur naturelle
 Natürliche Farbe

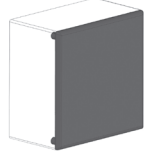

Tappo - Cap - Tapón - Embout - Abdeckkappe			
			
Cod	Mat	g	Col
084.201.057	PA	12	■
084.201.057G	PA	12	■

ASSEMBLY SYSTEMS
SISTEMI DI MONTAGGIO
SISTEMAS DE MONTAJE
SISTÈMES DE MONTAGE
MONTAGESYSTEME

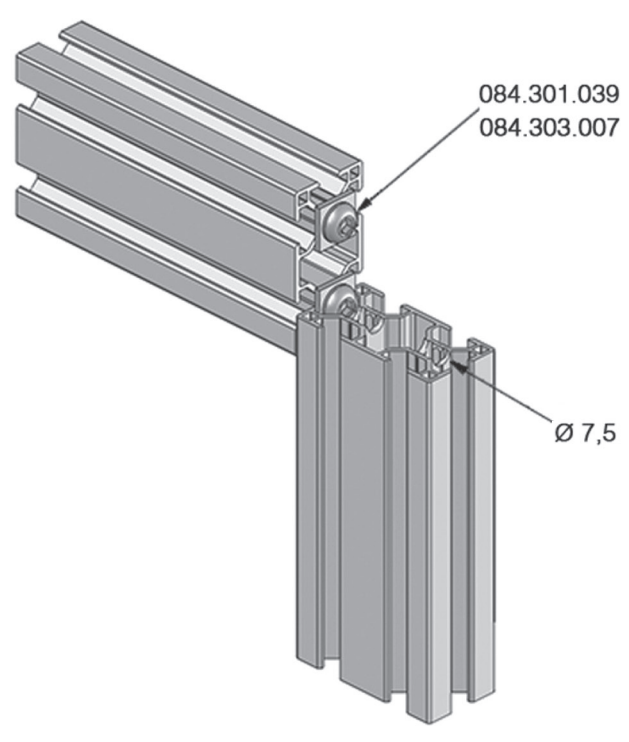
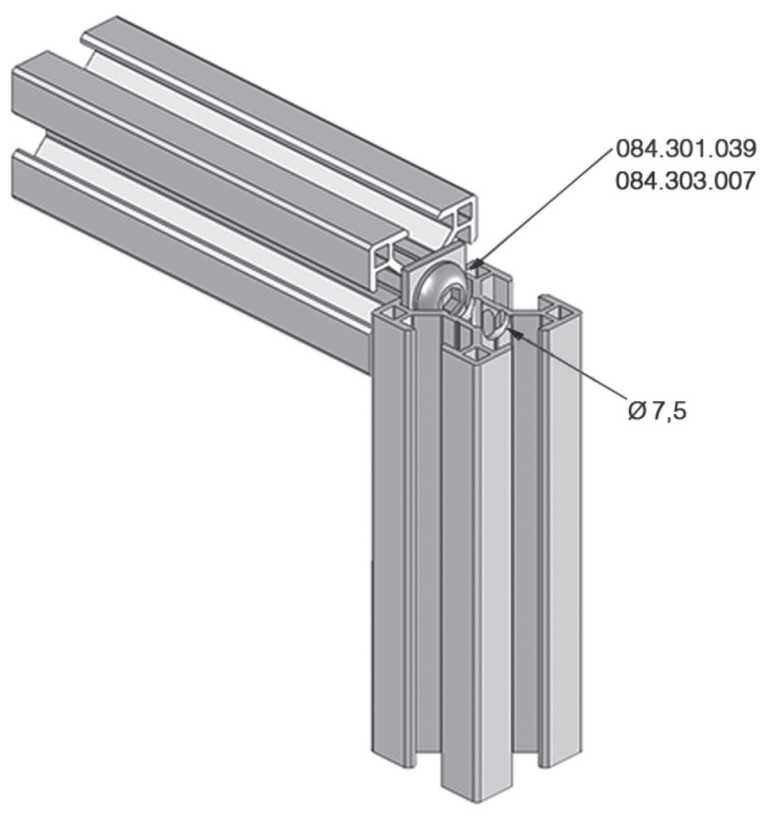



Alusic

PROFILES SERIES 40 SLOT 10 BH

PROFILI SERIE 40 CAVA 10 BH
PERFILES SERIE 40 RANURA 10 BH
PROFILÉS SÉRIE 40 RAINURE 10 BH
PROFILE REIHE 40 NUT 10 BH

EN

Alusic series 40 profiles, featuring a 10 mm fastening T-slot, represent the perfect compromise between lightness and solidity.

This range can be fastened with M8 hardware using suitable accessories, or by M12 threading at the ends of the bars. Nuts are available with M4, M5, M6 and M8 threads; they can be inserted at any point in the slot, even following initial assembly of the structure.

IT

I profili Alusic serie 40, dotati di una cava di fissaggio da 10 mm a "T", rappresentano il giusto compromesso tra leggerezza e robustezza.

La serie permette il fissaggio con viti M8 tramite gli opportuni accessori di fissaggio o tramite filettatura M12 alle estremità delle barre. Per quanto riguarda i dadi sono disponibili con filetti M4, M5, M6 e M8; possono essere inseriti in qualunque punto della cava anche successivamente al primo montaggio della struttura.

ES

Los perfiles Alusic serie 40, dotados de una ranura de fijación de 10 mm en "T", ofrecen un equilibrio perfecto entre ligereza y robustez.

La serie permite la fijación con tornillos M8 mediante los correspondientes accesorios de fijación o mediante roscado M12 en los extremos de las barras. En lo que respecta a las tuercas, están disponibles con roscas M4, M5, M6 y M8; pueden insertarse en cualquier punto de la ranura, incluso con posterioridad al primer montaje de la estructura.

FR

Les profilés Alusic série 40, dotés d'une rainure de fixation de 10 mm en « T », représentent le juste compromis entre légèreté et robustesse.

La série permet la fixation à l'aide de vis M8, au moyen des accessoires de fixation appropriés ou par filetage M12 à l'extrémité des barres. Concernant les écrous, ils sont disponibles avec filetages M4, M5, M6 et M8 ; ils peuvent être introduits à hauteur de tout point de la rainure, y compris après le premier montage de la structure.

DE

Die Alusic-Profilе der Reihe 40 mit T-förmiger Befestigungsnut zu 10 mm stellen die richtige Mischung zwischen Leichtigkeit und Robustheit dar.

Die Reihe ermöglicht die Befestigung mit Schrauben M8 durch das geeignete Befestigungszubehör oder durch Gewinde M12 an den Stangenenden. Die Muttern sind mit Gewinden M4, M5, M6 und M8 erhältlich; sie können an jeder Stelle der Nut auch nach der Erstmontage der Struktur eingesetzt werden.

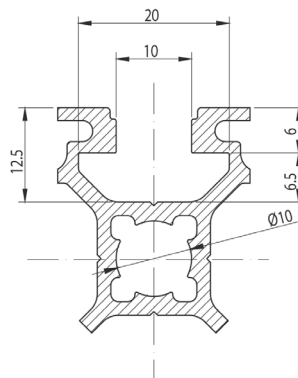

40x40

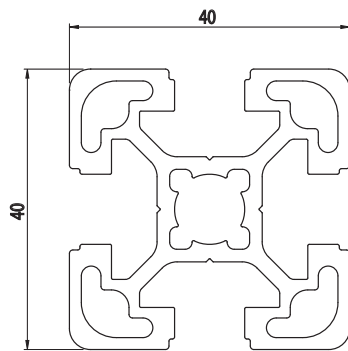
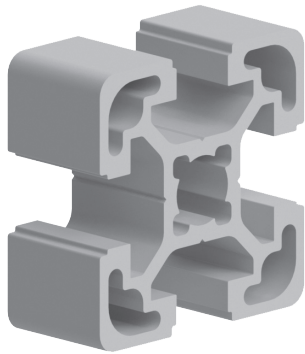

Cod	lx cm ⁴	ly cm ⁴	wx cm ³	wy cm ³	mm ²	Kg/m
084.113.001	8,89	8,89	4,45	4,45	553,50	1,49

Anodised aluminium

Alluminio anodizzato
Aluminio anodizado
Aluminium anodisé
Eloxiertes Aluminium
L=6040 mm

Natural colour

Colore naturale
Color natural
Couleur naturelle
Natürliche Farbe

Tappo - Cap - Tapòn - Embout - Abdeckkappe			
Cod	Mat	g	Col
084.201.064	PA	5	■
084.201.064G	PA	5	■

40x80

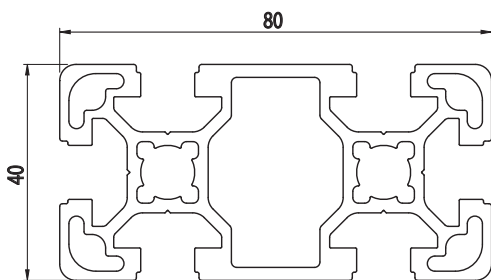
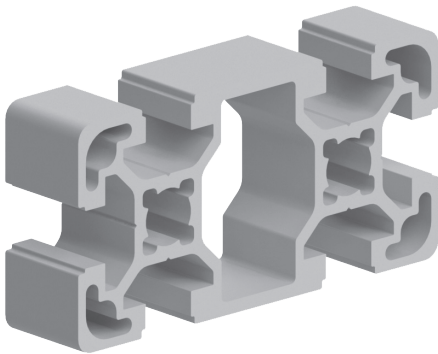

Cod	lx cm ⁴	ly cm ⁴	wx cm ³	wy cm ³	mm ²	Kg/m
084.113.002	62,26	17,35	15,57	8,68	979,60	2,64

Anodised aluminium

Alluminio anodizzato
Aluminio anodizado
Aluminium anodisé
Eloxiertes Aluminium
L=6040 mm

Natural colour

Colore naturale
Color natural
Couleur naturelle
Natürliche Farbe

Tappo - Cap - Tapòn - Embout - Abdeckkappe			
Cod	Mat	g	Col
084.201.065	PA	10	■
084.201.065G	PA	10	■

80x80

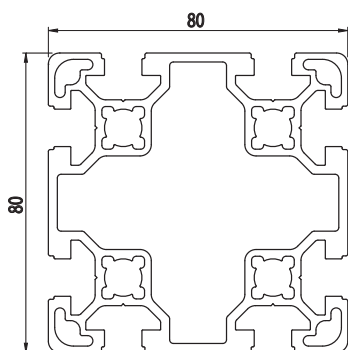
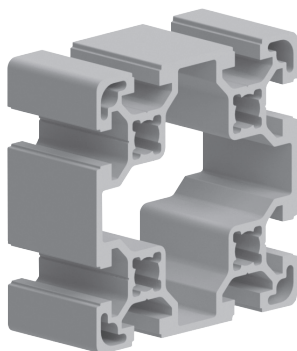

BH
105
40

Cod	lx cm ⁴	ly cm ⁴	wx cm ³	wy cm ³	mm ²	Kg/m
084.113.003	114,55	114,55	28,64	28,64	1554,20	4,20

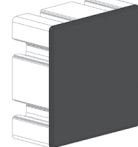

Anodised aluminium
Alluminio anodizzato
Aluminio anodizado
Aluminium anodisé
Eloxiertes Aluminium
L=6040 mm

Natural colour
Colore naturale
Color natural
Couleur naturelle
Natürliche Farbe

Tappo - Cap - Tapón - Embout - Abdeckkappe			
			
Cod	Mat	g	Col
084.201.066	PA	18	■
084.201.066G	PA	18	■

ASSEMBLY SYSTEMS
SISTEMI DI MONTAGGIO
SISTEMAS DE MONTAJE
SISTÈMES DE MONTAGE
MONTAGESYSTEME

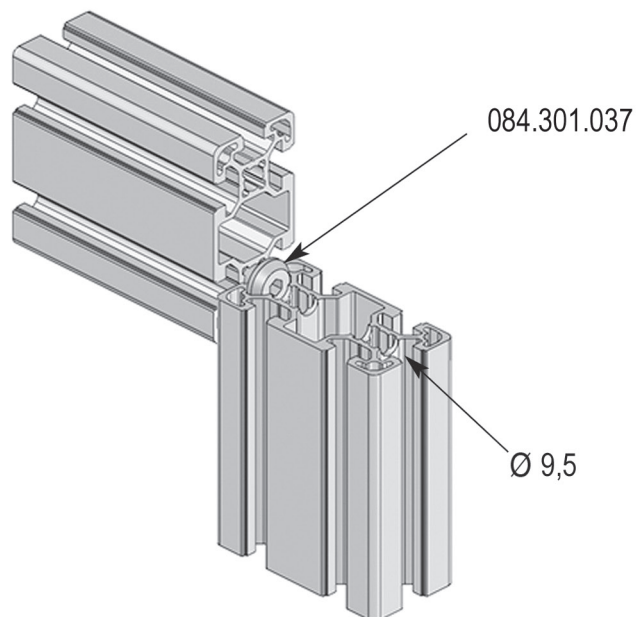
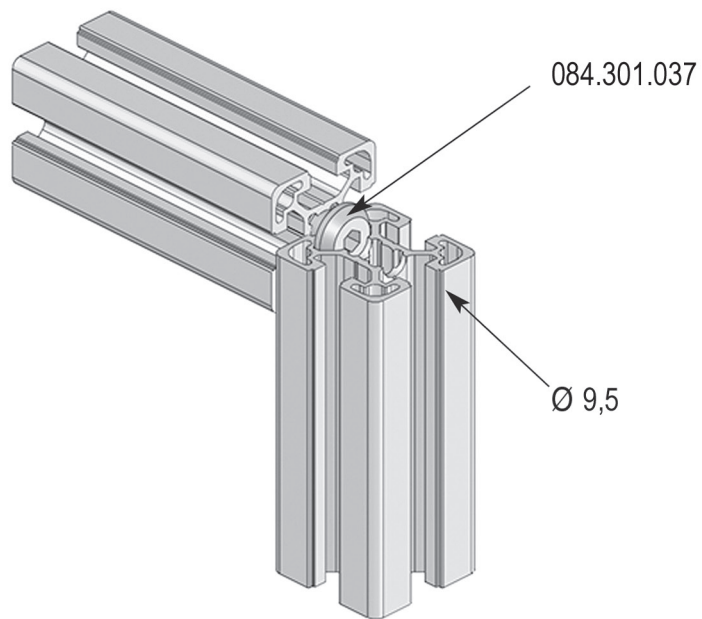





Alusic

PROFILES SERIES 45 SLOT 10 BH

PROFILI SERIE 45 CAVA 10 BH
PERFILES SERIE 45 RANURA 10 BH
PROFILÉS SÉRIE 45 RAINURE 10 BH
PROFILE REIHE 45 NUT 10 BH

EN Alusic series 45 profiles, featuring a 10 mm fastening T-slot, are one of the most popular ranges in the Alusic catalogue.

The range is completed by profiles with closed or tear-off slots, ideal for the food sector; it is also the base for our "FC Heavy" model range.

This range can be fastened with M8 hardware using suitable accessories, or by M12 threading at the ends of the bars. Nuts, also available in spring channel version, are available with M4, M5, M6 and M8 threads; they can be inserted at any point in the slot, even following initial assembly of the structure.

IT I profili Alusic serie 45, dotati di una cava di fissaggio da 10 mm a "T", rappresentano una delle gamme più utilizzate del catalogo Alusic.

La gamma è completa di profili con cave chiuse o pelabili ideali per il settore alimentare ed è inoltre la base per i modelli della linea "FC Heavy".

La serie permette il fissaggio con viti M8 tramite gli opportuni accessori di fissaggio o tramite filettatura M12 alle estremità delle barre. Per quanto riguarda i dadi, presenti anche nella versione a molla, sono disponibili con filetti M4, M5, M6 e M8; possono essere inseriti in qualunque punto della cava anche successivamente al primo montaggio della struttura.

ES Los perfiles Alusic serie 45, dotados de una ranura de fijación de 10 mm en "T", conforman una de las gamas más utilizadas del catálogo de Alusic.

La gama ofrece perfiles con ranuras cerradas o desgarrables, ideales para el sector alimentario, y además sirve de base para los modelos de la línea "FC Heavy".

La serie permite la fijación con tornillos M8 mediante los correspondientes accesorios de fijación o mediante roscado M12 en los extremos de las barras. En lo que respecta a las tuercas, también presentes en la versión con muelle, están disponibles con roscas M4, M5, M6 y M8; pueden insertarse en cualquier punto de la ranura, incluso con posterioridad al primer montaje de la estructura.

FR Les profilés Alusic série 45, dotés d'une rainure de fixation de 10 mm en « T », constituent l'une des gammes les plus utilisées du catalogue Alusic.

La gamme comprend des profilés à rainures fermées ou pelables, idéals pour le secteur alimentaire ; de plus, elle constitue la base des modèles de la ligne « FC Heavy ».

La série permet la fixation à l'aide de vis M8, au moyen des accessoires de fixation appropriés ou par filetage M12 à l'extrémité des barres. Concernant les écrous, également présents dans la version à ressort, ils sont disponibles avec filetages M4, M5, M6 et M8 ; ils peuvent être introduits à hauteur de tout point de la rainure, y compris après le premier montage de la structure.

DE Die Alusic-Profilreihe der Reihe 45 mit T-förmiger Befestigungsnut zu 10 mm stellen eine der meist verwendeten Produktreihen des Alusic-Katalogs dar.

Die Produktreihe wird durch Profile mit geschlossenen oder schälbaren Nuten vervollständigt, die ideal für die Lebensmittelbranche sind; außerdem ist sie die Grundlage für die Modelle der Produktreihe „FC Heavy“.

Die Reihe ermöglicht die Befestigung mit Schrauben M8 durch das geeignete Befestigungszubehör oder durch Gewinde M12 an den Stangenenden. Die Muttern, die auch in der Ausführung mit Feder vorhanden sind, sind mit Gewinden M4, M5, M6 und M8 erhältlich; sie können an jeder Stelle der Nut auch nach der Erstmontage der Struktur eingesetzt werden.

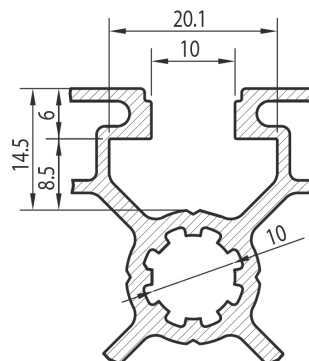

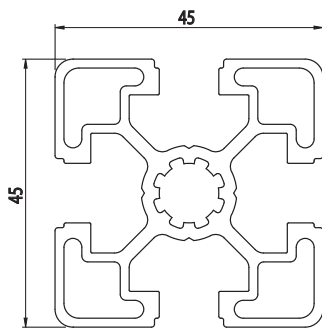
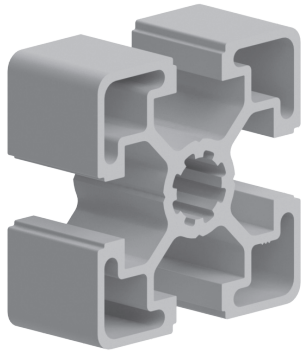

45x45

Cod	lx cm ⁴	ly cm ⁴	wx cm ³	wy cm ³	mm ²	Kg/m
084.105.004	11,33	11,33	5,04	5,04	573	1,56

Anodised aluminium
 Alluminio anodizzato
 Aluminio anodizado
 Aluminium anodisé
 Eloxiertes Aluminium
L=6040 mm

Natural colour
 Colore naturale
 Color natural
 Couleur naturelle
 Natürliche Farbe

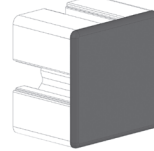
Tappo - Cap - Tapòn - Embout - Abdeckkappe			
			
Cod	Mat	g	Col
084.201.038	PA	7	■
084.201.038G	PA	7	■

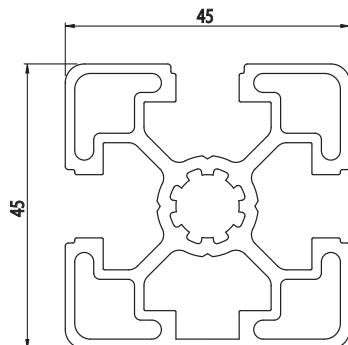
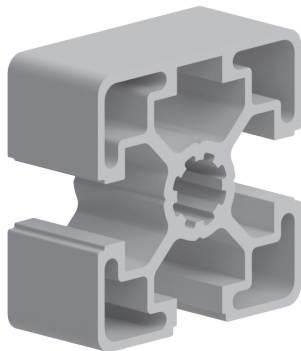

45x45

Cod	lx cm ⁴	ly cm ⁴	wx cm ³	wy cm ³	mm ²	Kg/m
084.105.010	10,89	11,68	4,75	5,07	582,70	1,57

Anodised aluminium
 Alluminio anodizzato
 Aluminio anodizado
 Aluminium anodisé
 Eloxiertes Aluminium
L=6040 mm

Natural colour
 Colore naturale
 Color natural
 Couleur naturelle
 Natürliche Farbe

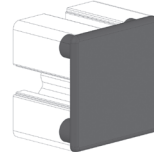
Tappo - Cap - Tapòn - Embout - Abdeckkappe			
			
Cod	Mat	g	Col
084.201.038	PA	7	■
084.201.038G	PA	7	■

45x45



Cod	lx cm ⁴	ly cm ⁴	wx cm ³	wy cm ³	mm2	Kg/m
084.105.011	11,70	11,70	5,10	5,10	600	1,62

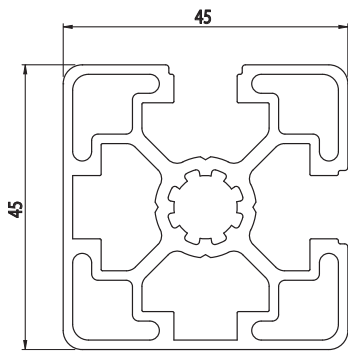
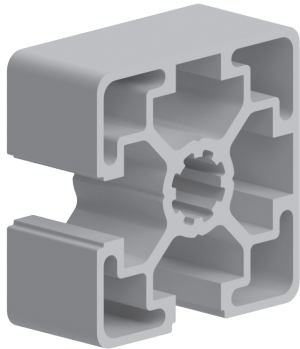

Anodised aluminium
Alluminio anodizzato
Aluminio anodizado
Aluminium anodisé
Eloxiertes Aluminium
L=6040 mm

Natural colour
Colore naturale
Color natural
Couleur naturelle
Natürliche Farbe

Tappo - Cap - Tapón - Embout - Abdeckkappe			
Cod	Mat	g	Col
084.201.038	PA	7	■
084.201.038G	PA	7	■

45x45



Cod	lx cm ⁴	ly cm ⁴	wx cm ³	wy cm ³	mm2	Kg/m
084.105.015	11,00	11,20	4,90	4,98	555,94	1,50

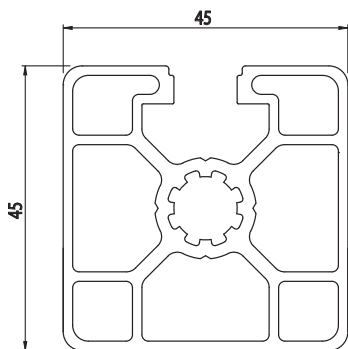
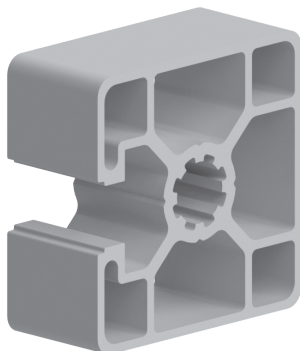

Anodised aluminium
Alluminio anodizzato
Aluminio anodizado
Aluminium anodisé
Eloxiertes Aluminium
L=6040 mm

Natural colour
Colore naturale
Color natural
Couleur naturelle
Natürliche Farbe

Tappo - Cap - Tapón - Embout - Abdeckkappe			
Cod	Mat	g	Col
084.201.038	PA	7	■
084.201.038G	PA	7	■

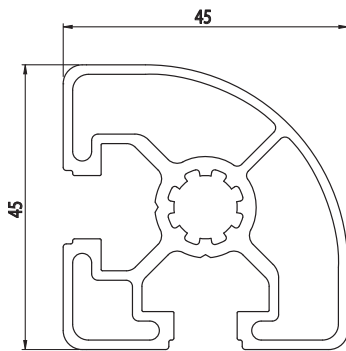
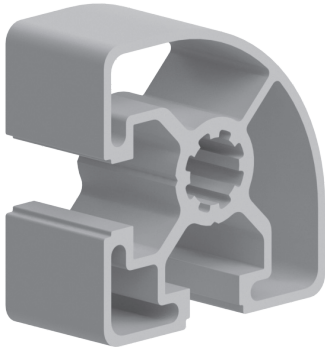

45x45

Cod	lx cm ⁴	ly cm ⁴	wx cm ³	wy cm ³	mm ²	Kg/m
084.105.012	8,37	8,37	3,35	3,35	476	1,29

Anodised aluminium
 Alluminio anodizzato
 Aluminio anodizado
 Aluminium anodisé
 Eloxiertes Aluminium
L=6040 mm

Natural colour
 Colore naturale
 Color natural
 Couleur naturelle
 Natürliche Farbe

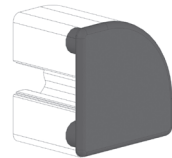
Tappo - Cap - Tapón - Embout - Abdeckkappe			
			
Cod	Mat	g	Col
084.201.071	PA	7	■
084.201.071G	PA	7	■

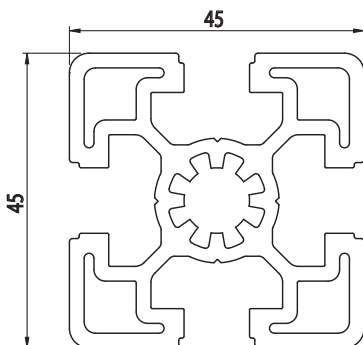
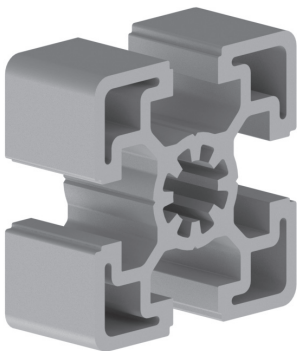

45x45

Cod	lx cm ⁴	ly cm ⁴	wx cm ³	wy cm ³	mm ²	Kg/m
084.105.018	14,82	14,82	6,59	6,59	750,45	2,03

Anodised aluminium
 Alluminio anodizzato
 Aluminio anodizado
 Aluminium anodisé
 Eloxiertes Aluminium
L=6040 mm

Natural colour
 Colore naturale
 Color natural
 Couleur naturelle
 Natürliche Farbe

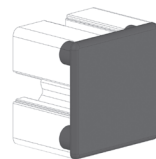
Tappo - Cap - Tapón - Embout - Abdeckkappe			
			
Cod	Mat	g	Col
084.201.038	PA	7	■
084.201.038G	PA	7	■

45x60



Cod	lx cm ⁴	ly cm ⁴	wx cm ³	wy cm ³	mm ²	Kg/m
084.105.007	35,00	20,90	11,70	9,30	1038	2,80

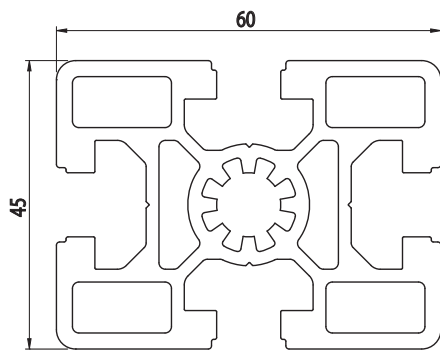

Anodised aluminium
Alluminio anodizzato
Aluminio anodizado
Aluminium anodisé
Eloxiertes Aluminium
L=6040 mm

Natural colour
Colore naturale
Color natural
Couleur naturelle
Natürliche Farbe

Tappo - Cap - Tapón - Embout - Abdeckkappe			
Cod	Mat	g	Col
084.201.052	PA	11	■
084.201.052G	PA	11	■

45x90



Cod	lx cm ⁴	ly cm ⁴	wx cm ³	wy cm ³	mm ²	Kg/m
084.105.006	82,27	23,49	18,28	10,44	1132	2,86

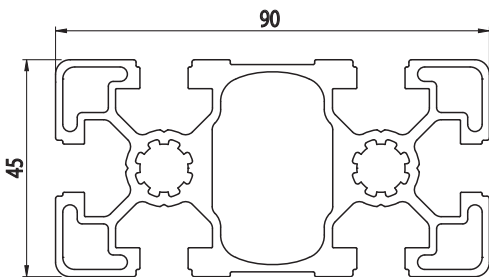
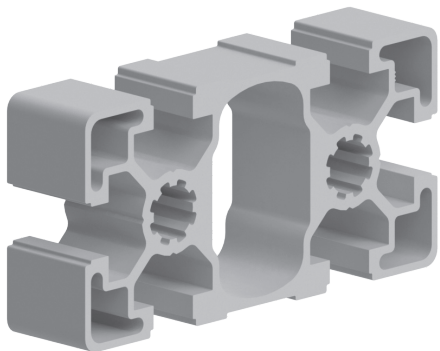

Anodised aluminium
Alluminio anodizzato
Aluminio anodizado
Aluminium anodisé
Eloxiertes Aluminium
L=6040 mm

Natural colour
Colore naturale
Color natural
Couleur naturelle
Natürliche Farbe

Tappo - Cap - Tapón - Embout - Abdeckkappe			
Cod	Mat	g	Col
084.201.039	PA	12	■
084.201.039G	PA	12	■

45x90



Cod	lx cm ⁴	ly cm ⁴	wx cm ³	wy cm ³	mm ²	Kg/m
084.105.019	125,7	32,9	27,95	14,65	1519,1	4,12

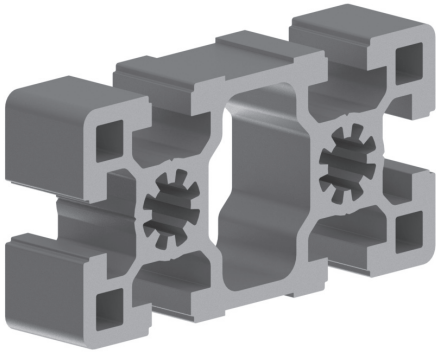

**Anodised aluminium**

Alluminio anodizzato
Aluminio anodizado
Aluminium anodisé
Eloxiertes Aluminium
L=6040 mm

Natural colour

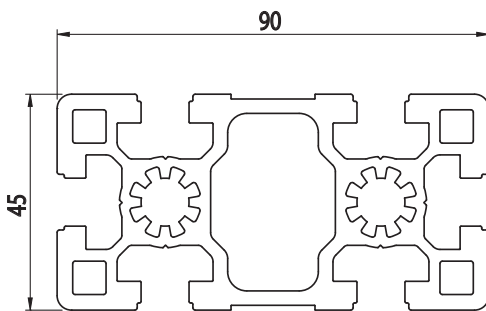
Colore naturale
Color natural
Couleur naturelle
Natürliche Farbe

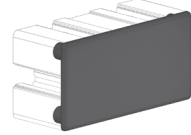

Tappo - Cap - Tapon - Embout - Abdeckkappe			
			
Cod	Mat	g	Col
084.201.039	PA	12	■
084.201.039G	PA	12	■

60x60



Cod	lx cm ⁴	ly cm ⁴	wx cm ³	wy cm ³	mm ²	Kg/m
084.105.008	52,57	52,57	17,52	17,52	1416	3,82

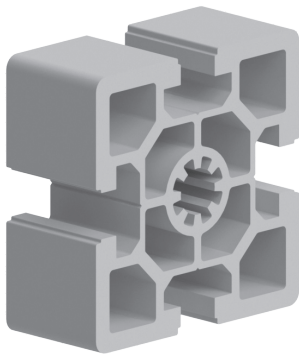

**Anodised aluminium**

Alluminio anodizzato
Aluminio anodizado
Aluminium anodisé
Eloxiertes Aluminium
L=6040 mm

Natural colour

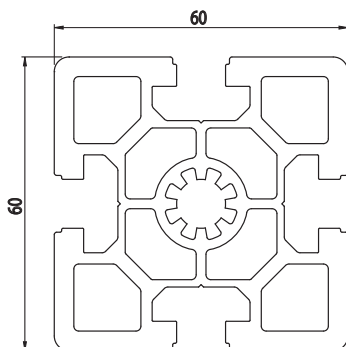
Colore naturale
Color natural
Couleur naturelle
Natürliche Farbe



Tappo - Cap - Tapon - Embout - Abdeckkappe			
			
Cod	Mat	g	Col
084.201.067	PA	18	■
084.201.067G	PA	18	■

90x90

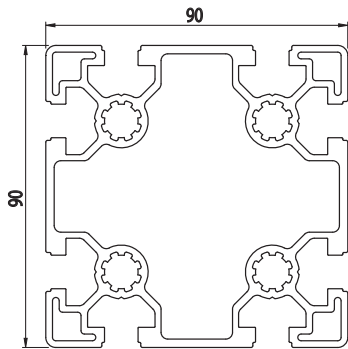
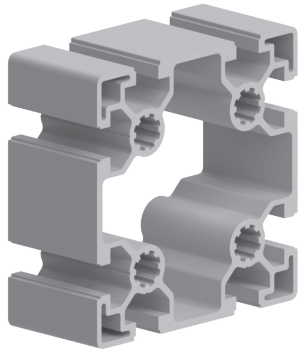

Cod	lx cm ⁴	ly cm ⁴	wx cm ³	wy cm ³	mm ²	Kg/m
084.105.005	174,93	174,93	38,97	38,97	1796	4,86

Anodised aluminium
Alluminio anodizzato
Aluminio anodizado
Aluminium anodisé
Eloxiertes Aluminium
L=6040 mm

Natural colour
Colore naturale
Color natural
Couleur naturelle
Natürliche Farbe

Tappo - Cap - Tapòn - Embout - Abdeckkappe			
Cod	Mat	g	Col
084.201.040	PA	22	■
084.201.040G	PA	22	■

90x90

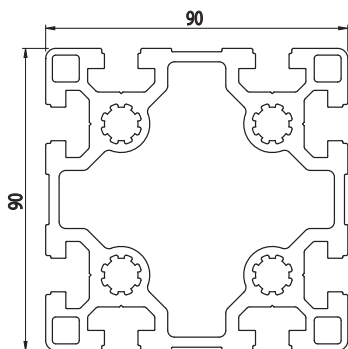
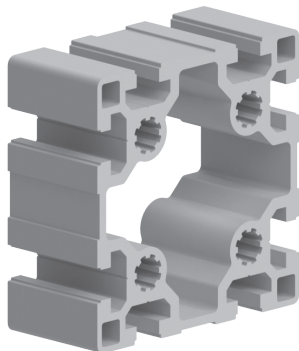

Cod	lx cm ⁴	ly cm ⁴	wx cm ³	wy cm ³	mm ²	Kg/m
084.105.014	219,32	219,32	48,74	48,74	2406	6,50

Anodised aluminium
Alluminio anodizzato
Aluminio anodizado
Aluminium anodisé
Eloxiertes Aluminium
L=6040 mm

Natural colour
Colore naturale
Color natural
Couleur naturelle
Natürliche Farbe

Tappo - Cap - Tapòn - Embout - Abdeckkappe			
Cod	Mat	g	Col
084.201.040	PA	22	■
084.201.040G	PA	22	■

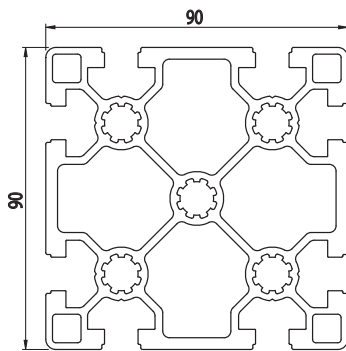
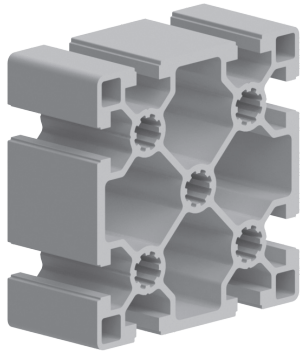

90x90

Cod	lx cm ⁴	ly cm ⁴	wx cm ³	wy cm ³	mm ²	Kg/m
084.105.009	187,50	187,50	41,67	41,67	2170,20	5,86

Anodised aluminium
 Alluminio anodizzato
 Aluminio anodizado
 Aluminium anodisé
 Eloxiertes Aluminium
L=6040 mm

Natural colour
 Colore naturale
 Color natural
 Couleur naturelle
 Natürliche Farbe

Tappo - Cap - Tapòn - Embout - Abdeckkappe			
			
Cod	Mat	g	Col
084.201.040	PA	22	■
084.201.040G	PA	22	■

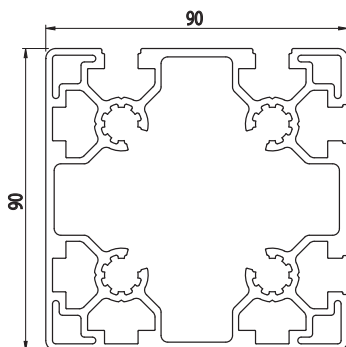
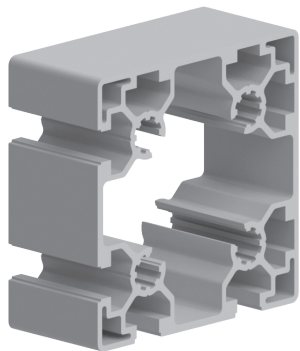

90x90

Cod	lx cm ⁴	ly cm ⁴	wx cm ³	wy cm ³	mm ²	Kg/m
084.105.016	173,53	173,53	38,56	38,56	1749	4,72

Anodised aluminium
 Alluminio anodizzato
 Aluminio anodizado
 Aluminium anodisé
 Eloxiertes Aluminium
L=6040 mm

Natural colour
 Colore naturale
 Color natural
 Couleur naturelle
 Natürliche Farbe

Tappo - Cap - Tapòn - Embout - Abdeckkappe			
			
Cod	Mat	g	Col
084.201.040	PA	22	■
084.201.040G	PA	22	■

90x90



Cod	lx cm ⁴	ly cm ⁴	wx cm ³	wy cm ³	mm ²	Kg/m
084.105.017	165,24	171,42	36,72	38	1705	4,60

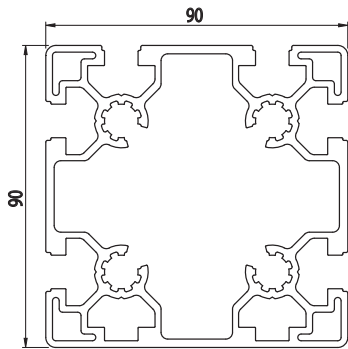
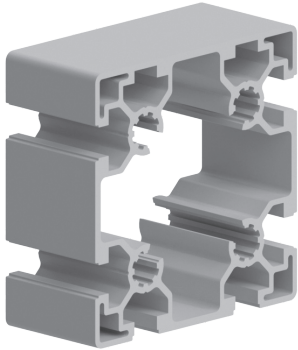

Anodised aluminium
Alluminio anodizzato
Aluminio anodizado
Aluminium anodisé
Eloxiertes Aluminium
L=6040 mm

Natural colour
Colore naturale
Color natural
Couleur naturelle
Natürliche Farbe

Tappo - Cap - Tapòn - Embout - Abdeckkappe			
Cod	Mat	g	Col
084.201.040	PA	22	■
084.201.040G	PA	22	■

90x180



Cod	lx cm ⁴	ly cm ⁴	wx cm ³	wy cm ³	mm ²	Kg/m
084.105.013	1430,10	418,90	158,33	93,09	4323	11,67

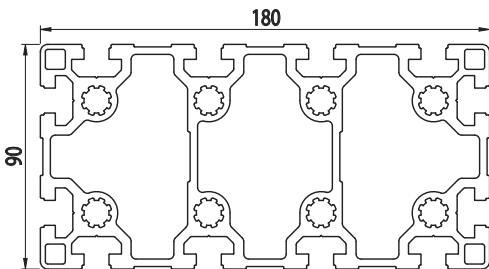
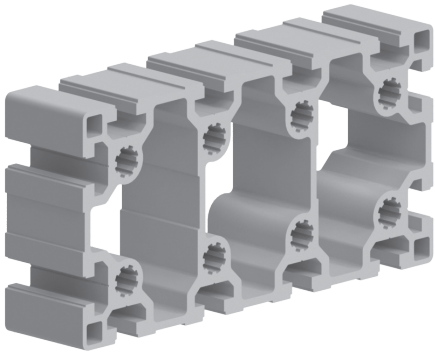

Anodised aluminium
Alluminio anodizzato
Aluminio anodizado
Aluminium anodisé
Eloxiertes Aluminium
L=6040 mm

Natural colour
Colore naturale
Color natural
Couleur naturelle
Natürliche Farbe

Tappo - Cap - Tapòn - Embout - Abdeckkappe			
Cod	Mat	g	Col
084.201.074	PA	18	■
084.201.074G	PA	18	■

135x225

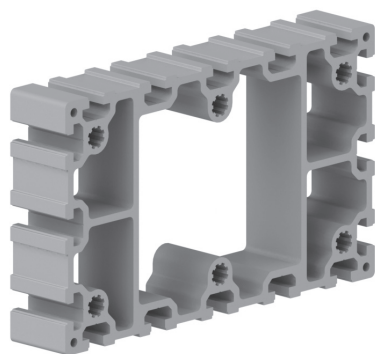

Cod	Ix cm ⁴	Iy cm ⁴	wx cm ³	wy cm ³	mm ²	Kg/m
084.105.020	4074	1632	603,5	145	6882	18,58

**Anodised aluminium**

Alluminio anodizzato
 Aluminio anodizado
 Aluminium anodisé
 Eloxiertes Aluminium

L=6040 mm**Natural colour**

Colore naturale
 Color natural
 Couleur naturelle
 Natürliche Farbe

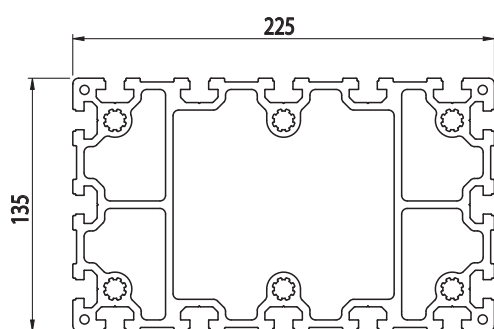

ASSEMBLY SYSTEMS

SISTEMI DI MONTAGGIO
SISTEMAS DE MONTAJE
SISTÈMES DE MONTAGE
MONTAGESYSTEME

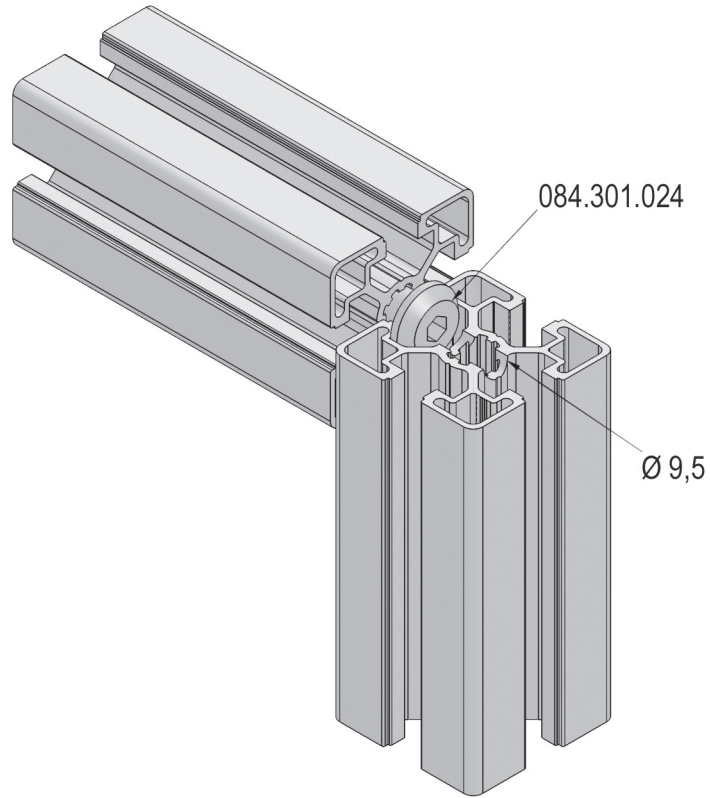



Alusic

PROFILES SERIES 50 SLOT 10 BH

PROFILI SERIE 50 CAVA 10 BH
PERFILES SERIE 50 RANURA 10 BH
PROFILÉS SÉRIE 50 RAINURE 10 BH
PROFILE REIHE 50 NUT 10 BH

EN Alusic series 50 profiles, featuring a 10 mm fastening T-slot, are one of the strongest ranges in the Alusic catalogue.

This range can be fastened with M8 hardware using suitable accessories, or by M12 threading at the ends of the bars. Nuts, also available in spring channel version, are available with M4, M5, M6 and M8 threads; they can be inserted at any point in the slot, even following initial assembly of the structure.

IT I profili Alusic serie 50, dotati di una cava di fissaggio da 10 mm a "T", rappresentano una delle gamme più robuste del catalogo Alusic.

La serie permette il fissaggio con viti M8 tramite gli opportuni accessori di fissaggio o tramite filettatura M12 alle estremità delle barre. Per quanto riguarda i dadi, presenti anche nella versione a molla, sono disponibili con filetti M4, M5, M6 e M8; possono essere inseriti in qualunque punto della cava anche successivamente al primo montaggio della struttura.

ES Los perfiles Alusic serie 50, dotados de una ranura de fijación de 10 mm en "T", conforman una de las gamas más robustas del catálogo de Alusic.

La serie permite la fijación con tornillos M8 mediante los correspondientes accesorios de fijación o mediante roscado M12 en los extremos de las barras. En lo que respecta a las tuercas, también presentes en la versión con muelle, están disponibles con roscas M4, M5, M6 y M8; pueden insertarse en cualquier punto de la ranura, incluso con posterioridad al primer montaje de la estructura.

FR Les profilés Alusic série 50, dotés d'une rainure de fixation de 10 mm en « T », constituent une des gammes les plus robustes du catalogue Alusic.

La série permet la fixation à l'aide de vis M8, au moyen des accessoires de fixation appropriés ou par filetage M12 à l'extrémité des barres. Concernant les écrous, également présents dans la version à ressort, ils sont disponibles avec filetages M4, M5, M6 et M8 ; ils peuvent être introduits à hauteur de tout point de la rainure, y compris après le premier montage de la structure.

DE Die Alusic-Profilen der Reihe 50 mit T-förmiger Befestigungsnut zu 10 mm stellen eine der robustesten Produktreihen des Alusic-Katalogs dar.

Die Reihe ermöglicht die Befestigung mit Schrauben M8 durch das geeignete Befestigungszubehör oder durch Gewinde M12 an den Stangenenden. Die Muttern, die auch in der Ausführung mit Feder vorhanden sind, sind mit Gewinden M4, M5, M6 und M8 erhältlich; sie können an jeder Stelle der Nut auch nach der Erstmontage der Struktur eingesetzt werden.

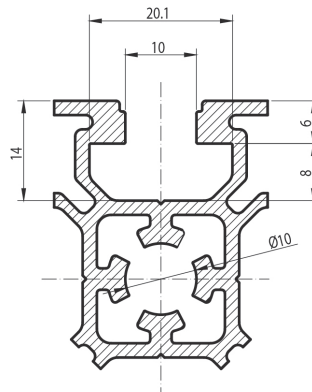

50x50

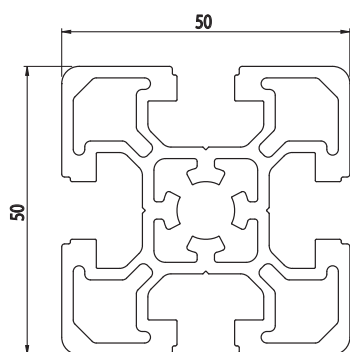
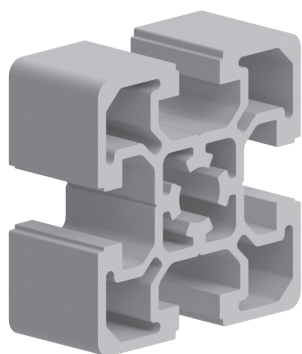

Cod	lx cm ⁴	ly cm ⁴	wx cm ³	wy cm ³	mm ²	Kg/m
084.109.001	21,04	21,04	8,42	8,42	865,00	2,34

Anodised aluminium

Alluminio anodizzato
Aluminio anodizado
Aluminium anodisé
Eloxiertes Aluminium
L=6040 mm

Natural colour

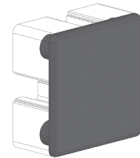
Colore naturale
Color natural
Couleur naturelle
Natürliche Farbe

Tappo - Cap - Tapòn - Embout - Abdeckkappe			
			
Cod	Mat	g	Col
084.201.055	PA	10	■
084.201.055G	PA	10	■

50x100

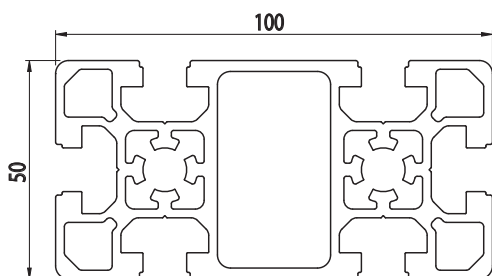
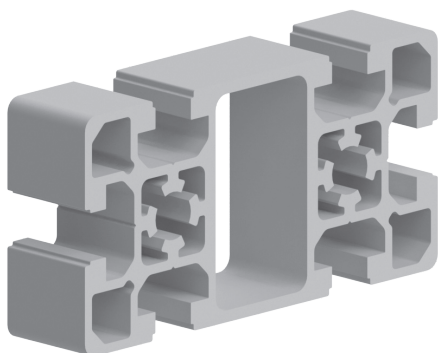

Cod	lx cm ⁴	ly cm ⁴	wx cm ³	wy cm ³	mm ²	Kg/m
084.109.002	161,80	41,40	32,40	16,56	1606	4,34

Anodised aluminium

Alluminio anodizzato
Aluminio anodizado
Aluminium anodisé
Eloxiertes Aluminium
L=6040 mm

Natural colour

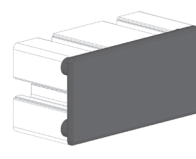
Colore naturale
Color natural
Couleur naturelle
Natürliche Farbe

Tappo - Cap - Tapòn - Embout - Abdeckkappe			
			
Cod	Mat	g	Col
084.201.056	PA	20	■
084.201.056G	PA	20	■

100x100

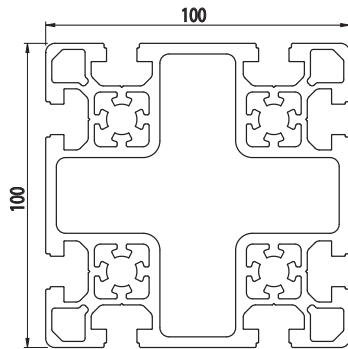
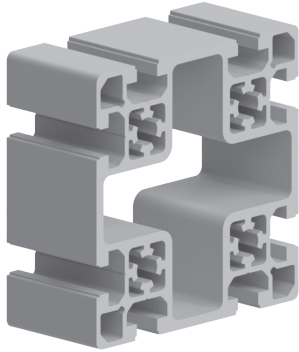

BH
105
50

Cod	lx cm ⁴	ly cm ⁴	wx cm ³	wy cm ³	mm ²	Kg/m
084.109.003	302,26	302,26	60,45	60,45	2832,28	7,65

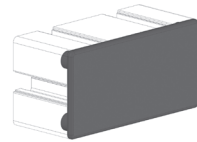

Anodised aluminium
Alluminio anodizzato
Aluminio anodizado
Aluminium anodisé
Eloxiertes Aluminium
L=6040 mm

Natural colour
Colore naturale
Color natural
Couleur naturelle
Natürliche Farbe

Tappo - Cap - Tapón - Embout - Abdeckkappe			
			
Cod	Mat	g	Col
084.201.068	PA	43	■
084.201.068G	PA	43	■

ASSEMBLY SYSTEMS
SISTEMI DI MONTAGGIO
SISTEMAS DE MONTAJE
SISTÈMES DE MONTAGE
MONTAGESYSTEME

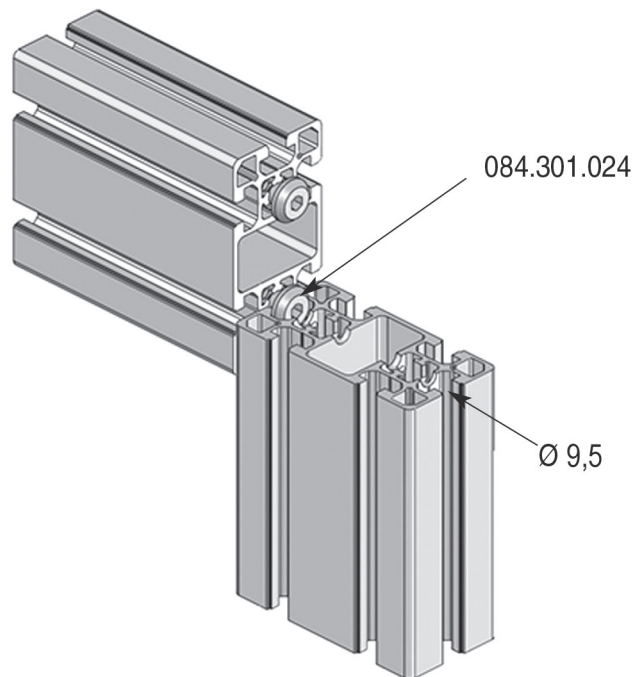
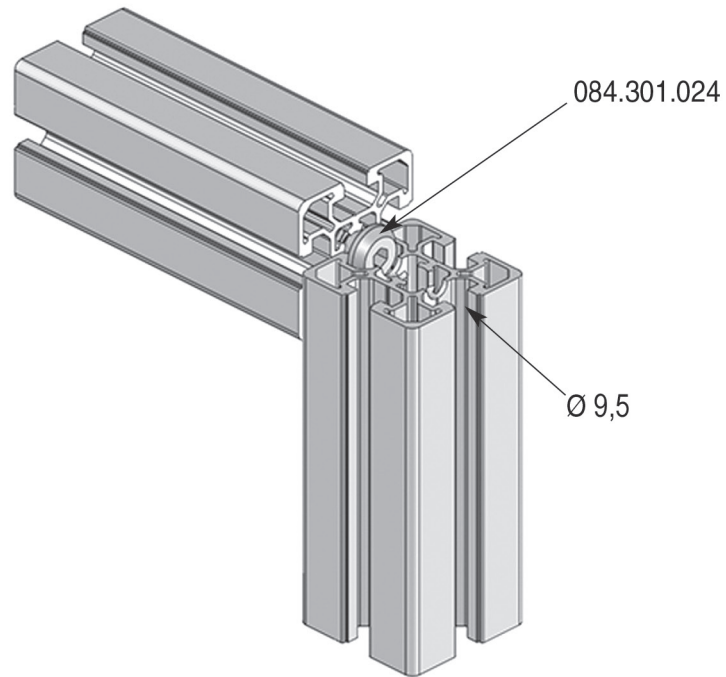





GUARD PROFILES

PROFILI PER RECINZIONI
PERFILES PARA CERRAMIENTOS
PROFILÉS POUR CLÔTURES
PROFILE FÜR UMZÄUNUNGEN



EN Our guard profiles are designed with optimised characteristics, geometries and weights for the creation of machine covers and guards.

IT I profili per le recinzioni sono nati per ottimizzare caratteristiche, geometrie e pesi per la realizzazione di coperture e recinzioni di macchine.

ES Los perfiles para cerramientos permiten optimizar las características, las geometrías y los pesos a la hora de realizar cubiertas y cercados de máquinas.

FR Les profilés pour clôtures ont été créés afin d'optimiser les caractéristiques, les formes et les poids pour la réalisation de couvertures et de clôtures de machines.

DE Die Profile für Umzäunungen wurden zur Optimierung der Eigenschaften, Geometrien und Gewichte für die Schaffung von Abdeckungen und Umzäunungen von Maschinen entwickelt.

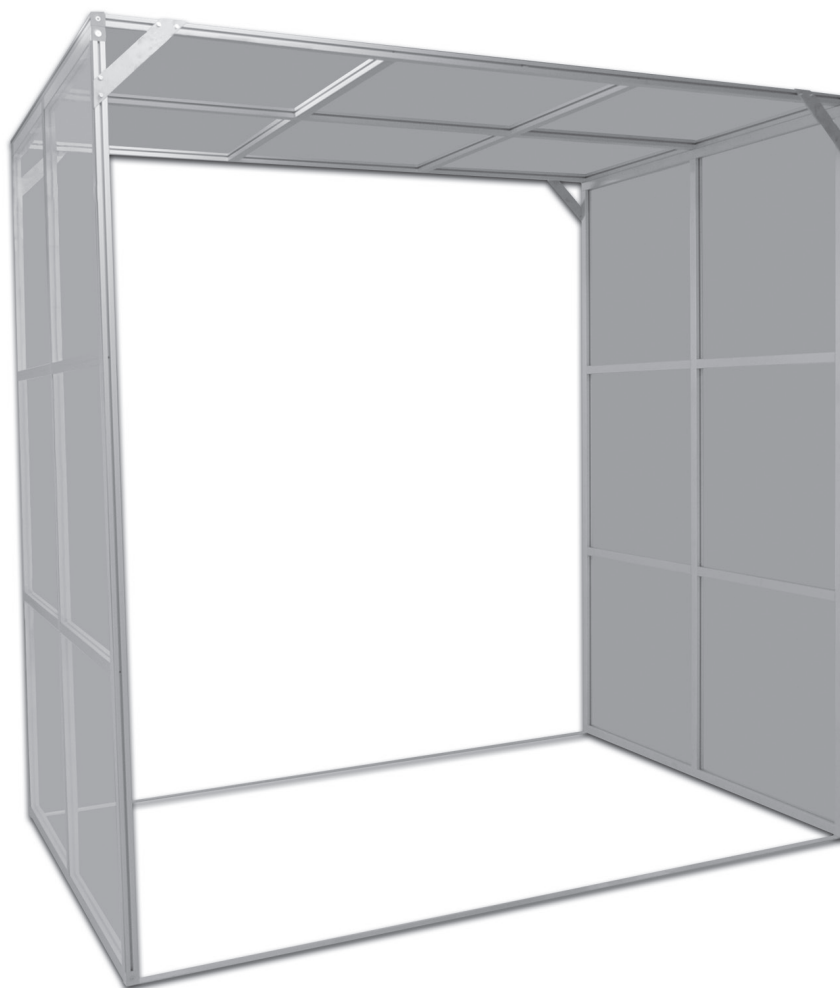



30x30

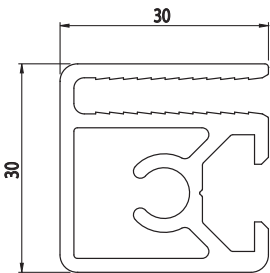
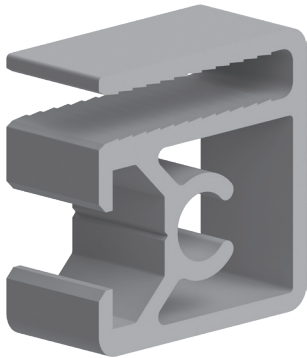

Cod	Ix cm ⁴	Iy cm ⁴	wx cm ³	wy cm ³	mm ²	Kg/m
084.104.003	2,87	3,46	1,94	2,29	339	0,92

Anodised aluminium

Alluminio anodizzato
Aluminio anodizado
Aluminium anodisé
Eloxiertes Aluminium
L=6040 mm

Natural colour

Colore naturale
Color natural
Couleur naturelle
Natürliche Farbe

30x50

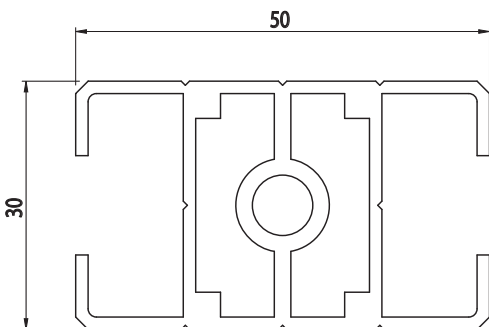
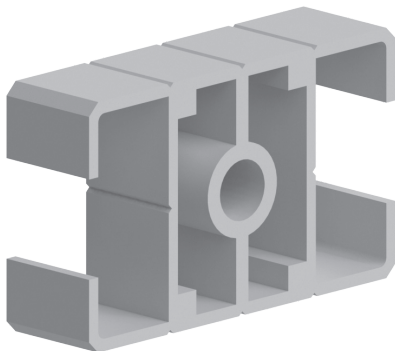

Cod	Ix cm ⁴	Iy cm ⁴	wx cm ³	wy cm ³	mm ²	Kg/m
084.112.001	6,62	4,25	2,65	2,83	360,31	0,97

Anodised aluminium

Alluminio anodizzato
Aluminio anodizado
Aluminium anodisé
Eloxiertes Aluminium
L=6040 mm

Natural colour

Colore naturale
Color natural
Couleur naturelle
Natürliche Farbe

Tappo - Cap - Tapòn - Embout - Abdeckkappe			
Cod	Mat	g	Col
084.201.069	PA	8	■
084.201.069G	PA	9	■



50x50

Cod	lx cm ⁴	ly cm ⁴	wx cm ³	wy cm ³	mm ²	Kg/m
084.112.002	14,44	13,31	5,78	5,32	582,38	1,57

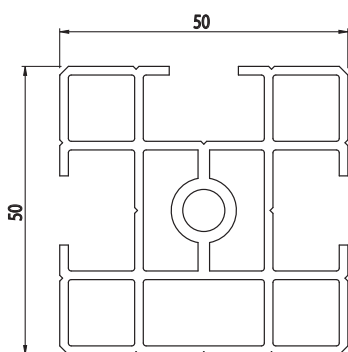
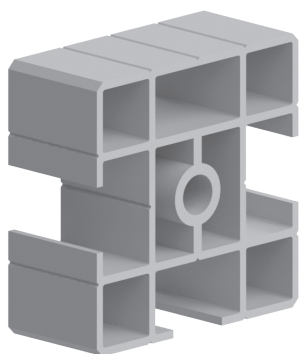

Anodised aluminium
 Alluminio anodizzato
 Aluminio anodizado
 Aluminium anodisé
 Eloxiertes Aluminium
L=6040 mm

Natural colour
 Colore naturale
 Color natural
 Couleur naturelle
 Natürliche Farbe

Tappo - Cap - Tapón - Embout - Abdeckkappe			
Cod	Mat	g	Col
084.201.070	PA	13	■
084.201.070G	PA	13	■



Alusic

SPECIAL PROFILES

PROFILI SPECIALI
PERFILES ESPECIALES
PROFILÉS SPÉCIAUX
SONDERPROFILE

EN This section contains profiles dedicated to special applications complementary to structural profiles, such as profiles for stairs or cable conduits.

IT In questa sezione vengono raccolti quei profili dedicati ad applicazioni speciali complementari ai profili strutturali, come il profilo per gli scalini o le canaline per i cavi.

ES Esta sección recoge los perfiles específicos para aplicaciones especiales complementarios a los perfiles estructurales, como los perfiles para peldaños o las canaletas para cables.

FR Cette section rassemble les profilés destinés à des applications spéciales complémentaires aux profilés structurels, comme le profilé pour marches ou les caniveaux pour câbles.

DE In diesem Abschnitt werden die Profile für Spezialanwendungen aufgeführt, die die Konstruktionsprofile ergänzen, wie zum Beispiel das Profil für Stufen oder Kabelkanäle.



30X30 CABLE CHANNEL

CANALINA PORTACAVI 30X30
 CANALETA PARA CABLES
 CANIVEAU À CÂBLES
 KABELKANAL

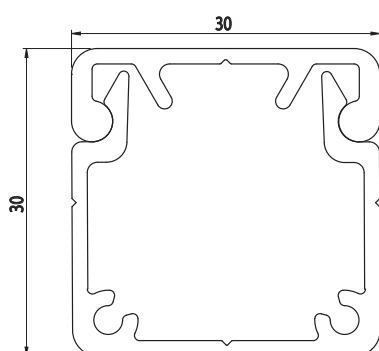
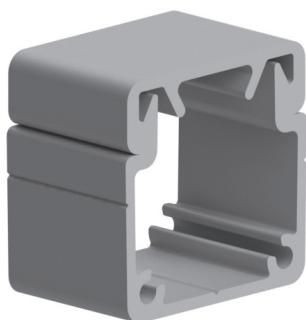

Cod	Note	Kg/m
084.101.092	Cable channel - Canalina - Canaletta para cables - Caniveau à câbles - Abdeckung Kabelkanal	0,45
084.101.093	Cable channel cover - Coperchio canalina - Tapa canaletta para cables - Couvercle caniveau à câbles - Abdeckung Kabelkanal	0,28

Anodised aluminium

Alluminio anodizzato
 Aluminio anodizado
 Aluminium anodisé
 Eloxiertes Aluminium
L=6040 mm

Natural colour

Colore naturale
 Color natural
 Couleur naturelle
 Natürliche Farbe

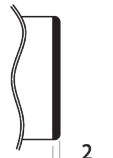
Cap - Tappo - Tapòn - Embout - Abdeck			
			
Cod	Mat	g	Col
084.201.096	ALL	4,7	■

40X40 CABLE CHANNEL

CANALINA PORTACAVI 40X40
 CANALETA PARA CABLES
 CANIVEAU À CÂBLES
 KABELKANAL

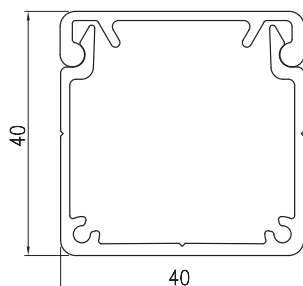



Cod	Note	Kg/m
084.101.097	Cable channel - Canalina - Canaletta para cables - Caniveau à câbles - Abdeckung Kabelkanal	0,6
084.101.098	Cable channel cover - Coperchio canalina - Tapa canaletta para cables - Couvercle caniveau à câbles - Abdeckung Kabelkanal	0,31

Anodised aluminium

Alluminio anodizzato
 Aluminio anodizado
 Aluminium anodisé
 Eloxiertes Aluminium
L=6040 mm

Natural colour

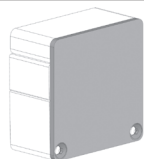
Colore naturale
 Color natural
 Couleur naturelle
 Natürliche Farbe

Cap - Tappo - Tapòn - Embout - Abdeck			
			
Cod	Mat	g	Col
084.201.097	ALL	8,5	■

CABLE CHANNEL

CANALINA PORTACAVI
 CANALETA PARA CABLES
 CANIVEAU À CÂBLES
 KABELKANAL

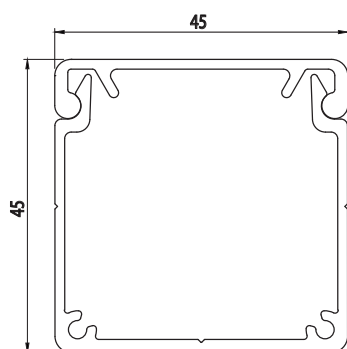
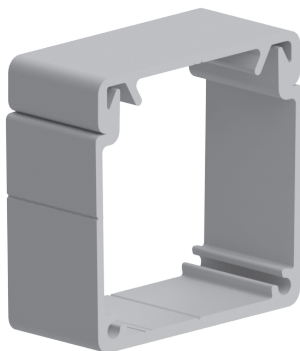

Cod	Note	Kg/m
084.101.053	Cable channel - Canalina - Canaletta para cables - Caniveau à câbles - Abdeckung Kabelkanal	0.70
084.101.054	Cable channel cover - Coperchio canalina - Tapa canaletta para cables - Couvercle caniveau à câbles - Abdeckung Kabelkanal	0,40

Anodised aluminium

Alluminio anodizzato
 Aluminio anodizado
 Aluminium anodisé
 Eloxiertes Aluminium
L=6040 mm

Natural colour

Colore naturale
 Color natural
 Couleur naturelle
 Natürliche Farbe

Cap - Tappo - Tapòn - Embout - Abdeck			
Cod	Mat	g	Col
084.201.053	ALL	15	■

CABLE CHANNEL

CANALINA PORTACAVI
 CANALETA PARA CABLES
 CANIVEAU À CÂBLES
 KABELKANAL

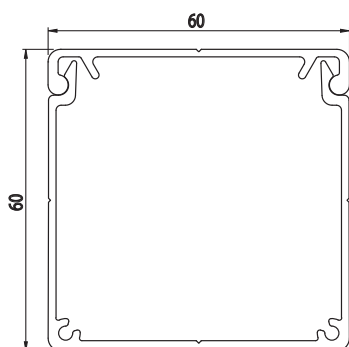
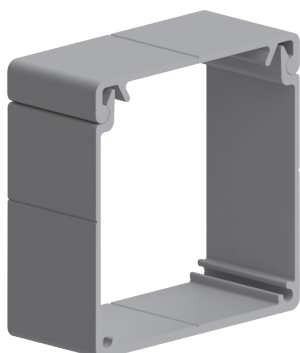

Cod	Note	Kg/m
084.101.078	Cable channel - Canalina - Canaletta para cables - Caniveau à câbles - Abdeckung Kabelkanal	0,87
084.101.079	Cable channel cover - Coperchio canalina - Tapa canaletta para cables - Couvercle caniveau à câbles - Abdeckung Kabelkanal	0,39

Anodised aluminium

Alluminio anodizzato
 Aluminio anodizado
 Aluminium anodisé
 Eloxiertes Aluminium
L=6040 mm

Natural colour

Colore naturale
 Color natural
 Couleur naturelle
 Natürliche Farbe

Cap - Tappo - Tapòn - Embout - Abdeck			
Cod	Mat	g	Col
084.201.079	ALL	19	■

**CABLE CHANNEL**

CANALINA PORTACAVI
CANALETA PARA CABLES
CANIVEAU À CÂBLES
KABELKANAL

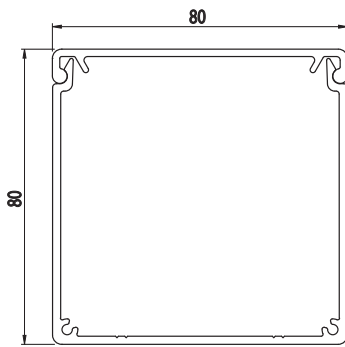



Cod	Note	Kg/m
084.101.055	Cable channel - Canalina - Canaletta para cables - Caniveau à câbles - Abdeckung Kabelkanal	1,50
084.101.056	Cable channel cover - Coperchio canalina - Tapa canaletta para cables - Couvercle caniveau à câbles - Abdeckung Kabelkanal	0,60

Anodised aluminium

Alluminio anodizzato
Aluminio anodizado
Aluminium anodisé
Eloxiertes Aluminium
L=6040 mm

Natural colour

Colore naturale
Color natural
Couleur naturelle
Natürliche Farbe

Cap - Tappo - Tapòn - Embout - Abdeck			
			
Cod	Mat	g	Col
084.201.059	ALL	30	■

120X80 CABLE CHANNEL

CANALINA PORTACAVI 120X80
CANALETA PARA CABLES
CANIVEAU À CÂBLES
KABELKANAL

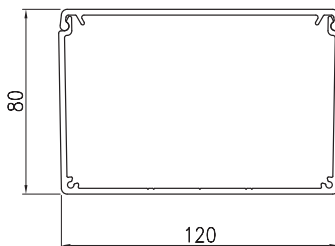



Cod	Note	Kg/m
084.101.099	Cable channel - Canalina - Canaletta para cables - Caniveau à câbles - Abdeckung Kabelkanal	1,86
084.101.100	Cable channel cover - Coperchio canalina - Tapa canaletta para cables - Couvercle caniveau à câbles - Abdeckung Kabelkanal	0,95

Anodised aluminium

Alluminio anodizzato
Aluminio anodizado
Aluminium anodisé
Eloxiertes Aluminium
L=6040 mm

Natural colour

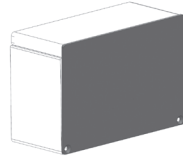
Colore naturale
Color natural
Couleur naturelle
Natürliche Farbe

Cap - Tappo - Tapòn - Embout - Abdeck			
			
Cod	Mat	g	Col
084.201.099	ALL	51,8	■

STEP
SCALINO
ESCALÓN
MARCHE
STUFE

Cod	lx cm ⁴	ly cm ⁴	wx cm ³	wy cm ³	mm ²	Kg/m
084.101.065	22,89	1239,82	10,06	91,16	1486,23	4,01

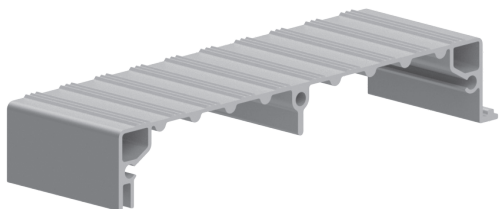

Anodised aluminium

Alluminio anodizzato
Aluminio anodizado
Aluminium anodisé
Eloxiertes Aluminium

L=6040 mm

Natural colour

Colore naturale
Color natural
Couleur naturelle
Natürliche Farbe

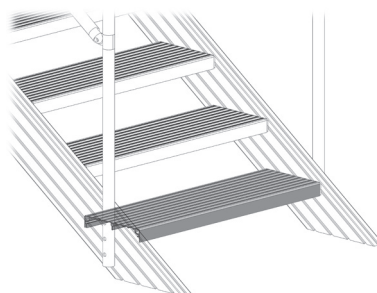
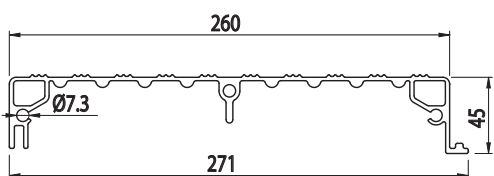



ACCESSORIES

ACCESSORI
ACCESORIOS
ACCESSOIRES
ZUBEHÖR



EN

Alusic is synonymous with a huge range of accessories especially designed for aluminium profiles. The result of a painstaking design process, tested with the aid of rapid prototyping techniques, our accessories are compatible with the majority of aluminium profiles on the market.

In this section you will find end caps, closure strips, fasteners, internal and external joints, bases, wheels, hinges, handles and components for sliders and creatingw guards.

IT

Alusic significa una vasta gamma di accessori studiati per i profili in alluminio. Frutto di un'attenta progettazione e testati con l'ausilio delle tecniche di prototipazione rapida, gli accessori sono compatibili con la maggior parte dei profili in alluminio presenti sul mercato.

In questa sezione possiamo trovare tappi di chiusura, chiudicava, viteria, giunti interni ed esterni, basi di ancoraggio, ruote, cerniere, maniglie ed elementi per scorrevoli e per la realizzazione di protezioni.

ES

Alusic ofrece una extensa gama de accesorios específicamente estudiados para los perfiles de aluminio. Fruto de un atento diseño y probados mediante técnicas de creación rápida de prototipos, los accesorios son compatibles con la mayoría de los perfiles de aluminio presentes en el mercado.

En esta sección encontrará tapones de cierre, taparranuras, tornillería, juntas internas y externas, bases de anclaje, ruedas, bisagras, asideros y elementos para correderas y para la realización de protecciones.

FR

Alusic est synonyme de vaste gamme d'accessoires étudiés pour les profilés en aluminium. Fruit d'une minutieuse conception et testés au moyen de techniques permettant la création rapide de prototypes, les accessoires sont compatibles avec la plupart des profilés en aluminium présents sur le marché.

La présente section contient des bouchons de fermeture, des fermetures de rainure, de la visserie, des joints internes et externes, des bases d'ancrage, des roues, des charnières, des poignées et des éléments pour coulissants et pour la réalisation de protections.

DE

Alusic bietet eine große Auswahl an Zubehör für Aluminiumprofile. Das Zubehör, das sorgsam entwickelt und mithilfe der Rapid-Prototyping-Techniken getestet wurde, ist mit den meisten auf dem Markt erhältlichen Aluminiumprofilen kompatibel.

In diesem Abschnitt finden wir Verschlusskappen, Verschießelemente für Nuten, Schrauben, innere und äußere Verbinder, Befestigungssockel, Räder, Scharniere, Griffe und Elemente für Schiebekonstruktionen und für die Schaffung von Schutzvorrichtungen.

**COVER PROFILE**

CHIUDICAVA RIGIDO
TAPA-RANURA
PROFILÉ DE RECOUVREMENT
ABDECKPROFIL

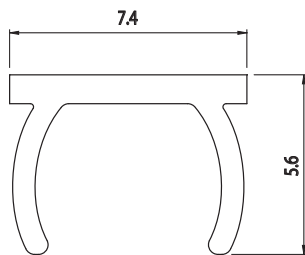
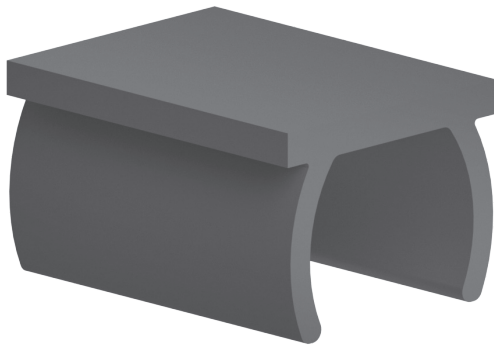
Cod	Note	g/m
084.203.023	L = 2000 mm	30

Rigid black PVC

PVC rigido nero
PVC rígido color negro
PVC rigide noir
Hart-PVC schwarz

Other colours on request

Altri colori a richiesta
Otros colores bajo solicitud
Autres couleurs sur demande
Weitere Farben auf Anfrage

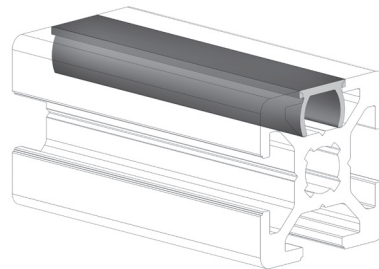
**COVER PROFILE**

CHIUDICAVA RIGIDO
TAPA-RANURA
PROFILÉ DE RECOUVREMENT
ABDECKPROFIL

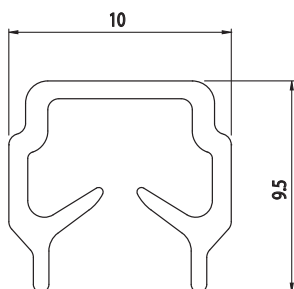
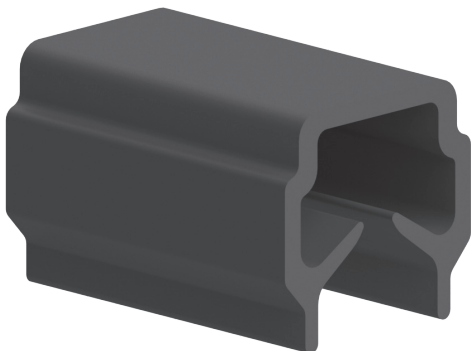
Cod	Note	g/m
084.203.024	L = 2000 mm	40

Rigid black PVC

PVC rigido nero
PVC rígido color negro
PVC rigide noir
Hart-PVC schwarz

Other colours on request

Altri colori a richiesta
Otros colores bajo solicitud
Autres couleurs sur demande
Weitere Farben auf Anfrage

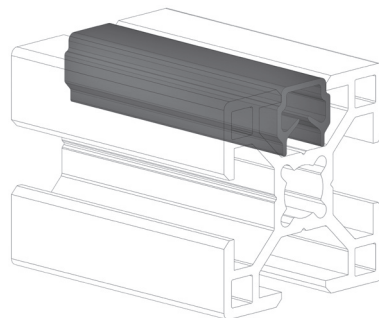



COVER PROFILE

CHIUDICAVA MORBIDO
TAPA-RANURA
PROFILÉ DE RECOUVREMENT
ABDECKPROFIL

BH 105 50 BH 105 45 BH 105 40

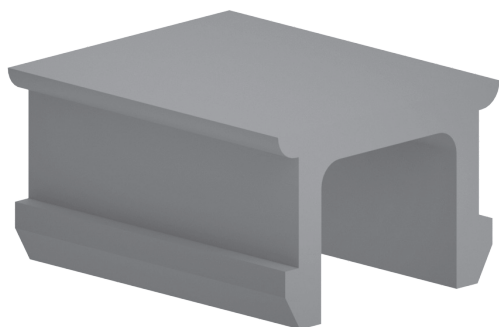

Cod	Note	Color	g/m
084.203.010	50 m rolls - rotoli 50 m - rollos de 50 m - rouleaux 50 m - Rollen 50 m	■	60
084.203.010N	50 m rolls - rotoli 50 m - rollos de 50 m - rouleaux 50 m - Rollen 50 m	■	60

Soft PVC
PVC morbido
PVC flexible
PVC souple
Weich-PVC

Other colours on request
Altri colori a richiesta
Otros colores bajo solicitud
Autres couleurs sur demande
Weitere Farben auf Anfrage

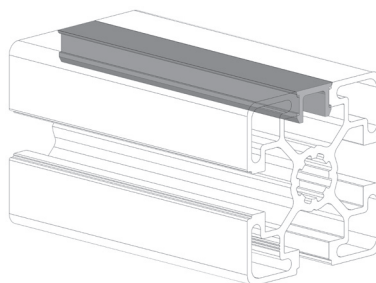
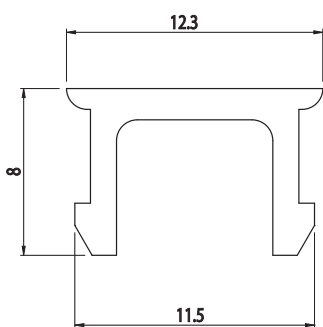

COVER PROFILE

CHIUDICAVA RIGIDO
TAPA-RANURA
PROFILÉ DE RECOUVREMENT
ABDECKPROFIL

BH 105 50 BH 105 45 BH 105 40

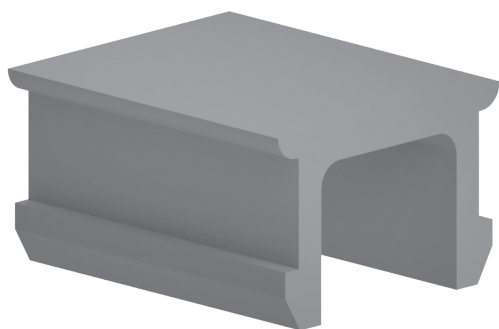

Cod	Note	Color	g/m
084.203.026	L = 2000 mm	■	60
084.203.027	L = 2000 mm	■	60

Rigid PVC
PVC rigido
PVC rígido
PVC rigide
Hart-PVC

Other colours on request
Altri colori a richiesta
Otros colores bajo solicitud
Autres couleurs sur demande
Weitere Farben auf Anfrage

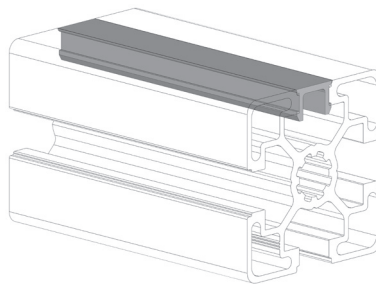
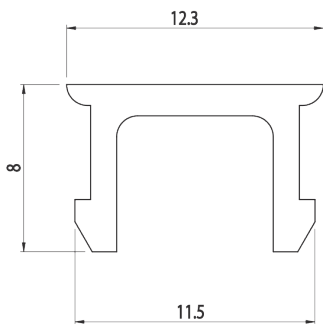

**CAP SCREWS**

VITI CILINDRICHE
TORNILLOS DE CABEZA CILÍNDRICA
VIS À TÊTE CYLINDRIQUE
ZYLINDERKOPFSCHRAUBEN

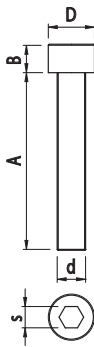

Cod	Note	d	A	D	B	s	g
084.301.008	M4x12	M4	12	7	2,5	2,5	1
084.301.054	M5x8	M5	8	8,50	3,50	3	2
084.301.009	M5x12	M5	12	8	3,50	3	3
084.301.035	M5x16	M5	16	8	3,50	3	3
084.301.036	M5x20	M5	20	8	3,50	3	4
084.301.010	M6x12	M6	12	10	4	4	4
084.301.011	M6x16	M6	16	10	4	4	5
084.301.001	M6x20	M6	20	10	4	4	6
084.301.002	M8x16	M8	16	13	5	5	8
084.301.003	M8x20	M8	20	13	5	5	10
084.301.012	M8x22	M8	22	13	5	5	12
084.301.004	M8x25	M8	25	13	5	5	12
084.301.038	M8x30	M8	30	13	5	5	15
084.301.013	M8x35	M8	35	13	5	5	18
084.301.005	M8x40	M8	40	13	5	5	18
084.301.006	M8x50	M8	50	13	5	5	20
084.301.007	M8x60	M8	60	13	5	5	24

Galvanised steel

Acciaio zincato
Acero galvanizado
Acier zingué
Verzinkter Stahl



CAP SCREWS

VITI CILINDRICHE
TORNILLOS DE CABEZA CILÍNDRICA
VIS À TÊTE CYLINDRIQUE
ZYLINDERKOPFSCHRAUBEN

STAINLESS STEEL

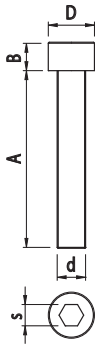

Cod	Note	d	A	D	B	s	g
084.301.032	M8x12	M8	12	13	8	6	8
084.301.029	M8x16	M8	16	13	8	6	11
084.301.025	M8x20	M8	20	13	8	6	13
084.301.033	M8x25	M8	25	13	8	6	15
084.301.031	M8x30	M8	30	13	8	6	16
084.301.026	M8x35	M8	35	13	8	6	17
084.301.027	M8x40	M8	40	13	8	6	20
084.301.030	M8x45	M8	45	13	8	6	21
084.301.028	M8x50	M8	50	13	8	6	22

Stainless steel

Acciaio inox
Acero inoxidable
Acier inox
Rostfreier Stahl

**BUTTON HEAD SCREWS**

VITI BOMBATE
TORNILLOS DE CABEZA ABOMBADA
VIS À TÊTE BOMBÉE
LINSENSCHRAUBEN

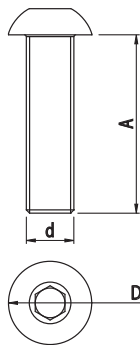

Cod	Note	d	A	D	B	s	g
084.301.079	M5x12	M5	12	10	-	-	3
084.301.040	M6x16	M6	16	10	-	-	5
084.301.039	M8x20	M8	20	14	-	-	6

Galvanised steel

Acciaio zincato
Acero galvanizado
Acier zingué
Verzinkter Stahl

BUTTON HEAD SCREW

VITE BOMBATA
TORNILLO DE CABEZA ABOMBADA
VIS À TÊTE BOMBÉE
LINSENSCHRAUBE

 

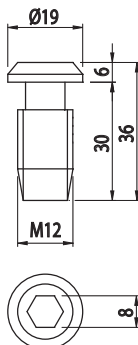

Cod	Note	g
084.301.024	M12x30	45

Galvanised steel

Acciaio zincato
Acero galvanizado
Acier zingué
Verzinkter Stahl

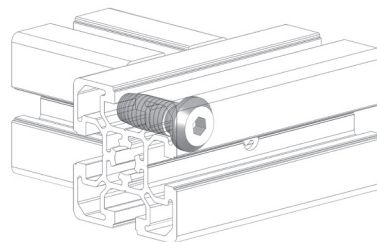



SELF-TAPPING SCREW

VITE AUTOFILETTANTE
TORNILLO AUTORROSCANTE
VIS TARAUDEUSE
GEWINDESCHNEIDENDE SCHRAUBE

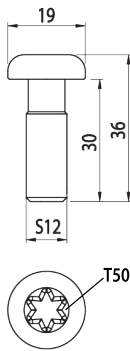

Cod	Note	g
084.301.037	S12x30	25

Galvanised steel

Acciaio zincato
Acero galvanizado
Acier zingué
Verzinkter Stahl

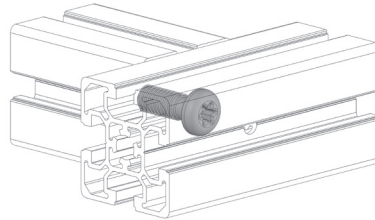

T-BOLTS

VITI A MARTELLO
TORNILLOS EN T
VIS À TÊTE MARTEAU
T-BOLZEN

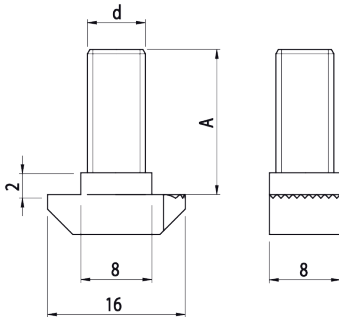
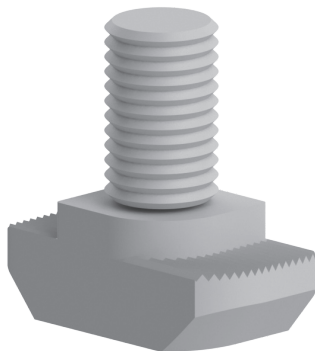

Cod	Note	d	A	D	B	s	g
084.301.041	M6x12	M6	12				8
084.301.042	M6x16	M6	16				9
084.301.043	M6x20	M6	20				10
084.301.044	M6x25	M6	25				11

Galvanised steel

Acciaio zincato
Acero galvanizado
Acier zingué
Verzinkter Stahl

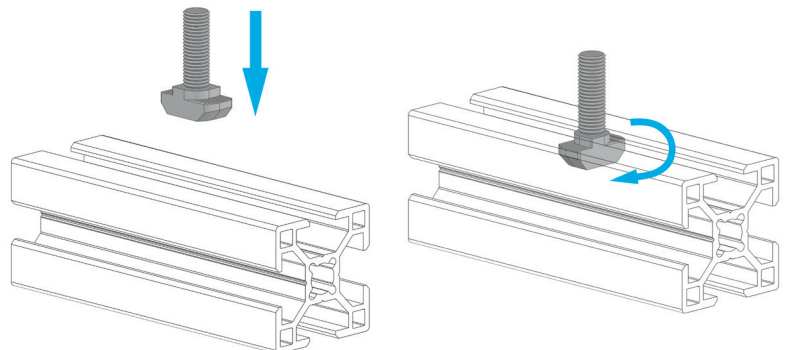

**T-BOLTS**

VITI A MARTELLO
TORNILLOS EN T
VIS À TÊTE MARTEAU
T-BOLZEN

BH 105 50
BH 105 45
BH 105 40

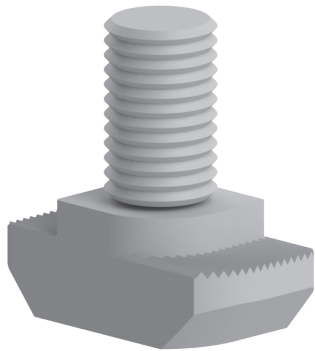

Cod	Note	d	A	D	B	s	g
084.301.018	M8x20	M8	20				13
084.301.019	M8x25	M8	25				15
084.301.020	M8x30	M8	30				16
084.301.045	M8x35	M8	35				18
084.301.021	M8x40	M8	40				20

Galvanised steel

Acciaio zincato
Acero galvanizado
Acier zingué
Verzinkter Stahl

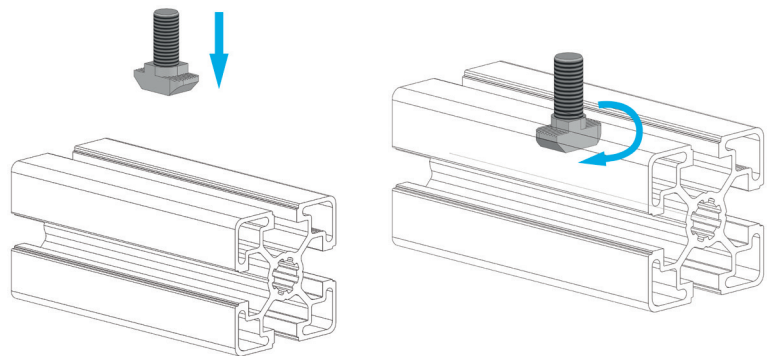
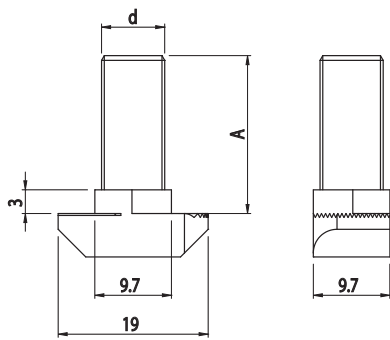



T-BOLTS

VITI A MARTELLO
TORNILLOS EN T
VIS À TÊTE MARTEAU
T-BOLZEN

STAINLESS STEEL

BH 105 50 BH 105 45 BH 105 40

Cod	Note	d	A	D	B	s	g
084.301.046	M8x20	M8	20				13
084.301.047	M8x25	M8	25				15

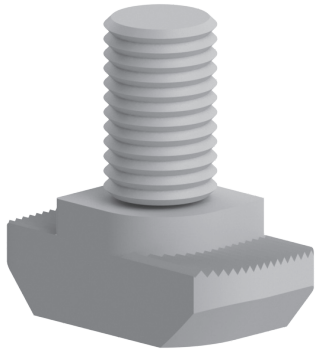

Stainless steel

Acciaio inox
Acero inoxidable
Acier inox
Rostfreier Stahl

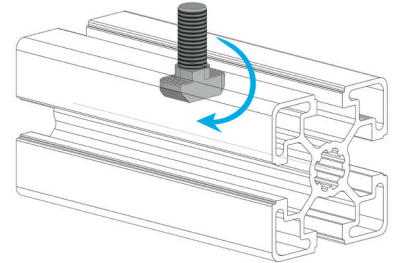
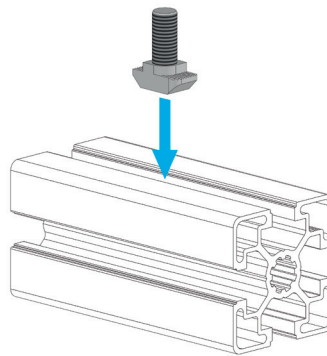
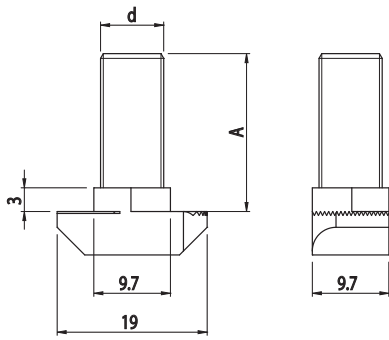

**T-NUT**

DADO A MARTELLO
TUERCA EN T
ÉCROU À TÊTE MARTEAU
HAMMERMUTTER

BH
6
20

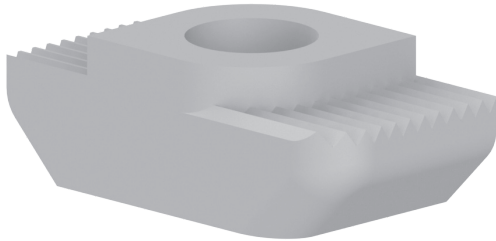

Cod	Note	g
084.302.021	M4	1
084.302.061	M5	1

Galvanised steel

Acciaio zincato
Acero galvanizado
Acier zingué
Verzinkter Stahl

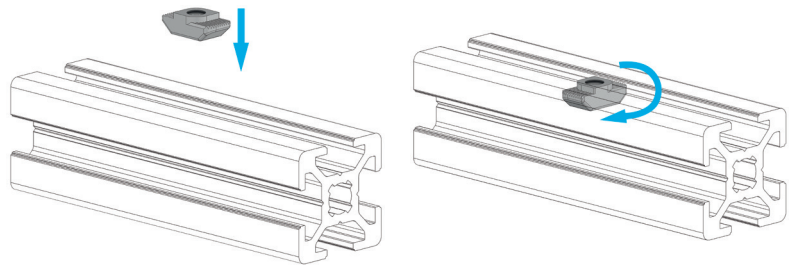
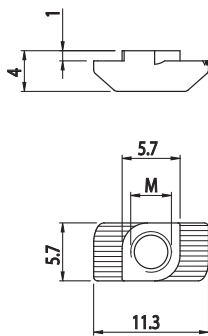
**T-NUT**

DADO A MARTELLO
TUERCA EN T
ÉCROU À TÊTE MARTEAU
HAMMERMUTTER

BH
8
30

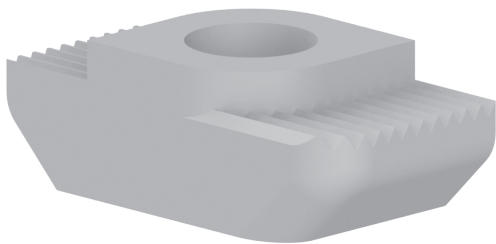

Cod	Note	g
084.302.022	M4	4
084.302.023	M5	3,5
084.302.024	M6	3

Galvanised steel

Acciaio zincato
Acero galvanizado
Acier zingué
Verzinkter Stahl

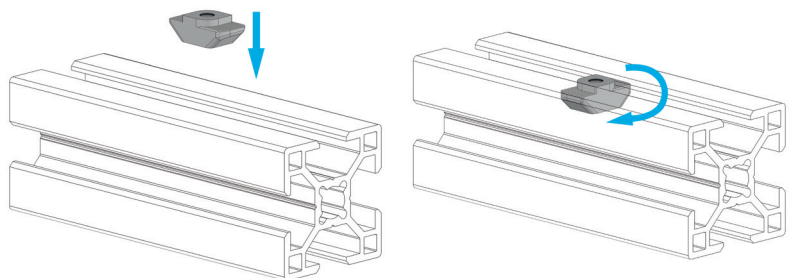
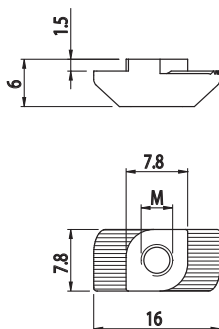



T-NUT

DADO A MARTELLO
TUERCA EN T
ÉCROU À TÊTE MARTEAU
HAMMERMUTTER

STAINLESS STEEL

BH
8
30

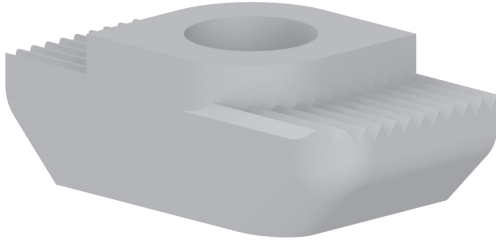

Cod	Note	g
084.302.062	M4	1
084.302.063	M5	1
084.302.064	M6	1

Stainless steel
Acciaio inox
Acero inoxidable
Acier inox
Rostfreier Stahl

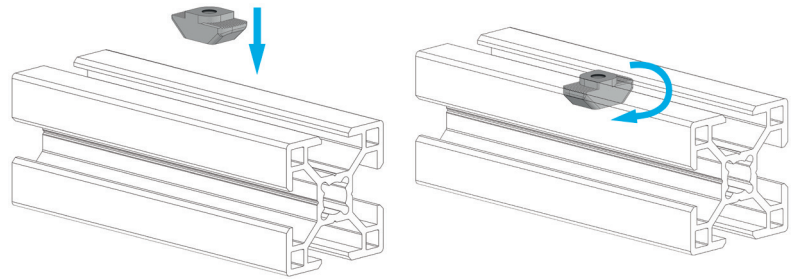
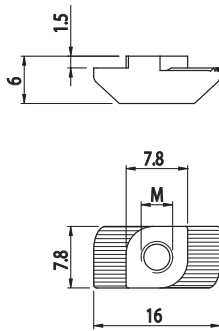

T-NUT

DADO A MARTELLO
TUERCA EN T
ÉCROU À TÊTE MARTEAU
HAMMERMUTTER

BH
10
50

BH
10
45

BH
10
40

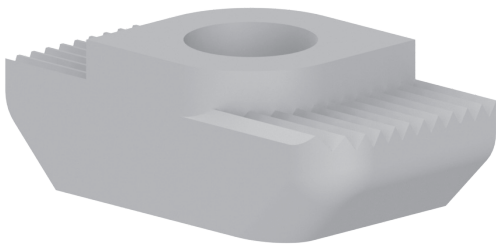

Cod	Note	g
084.302.025	M4	2
084.302.026	M5	2
084.302.027	M6	2
084.302.028	M8	1

Galvanised steel
Acciaio zincato
Acero galvanizado
Acier zingué
Verzinkter Stahl

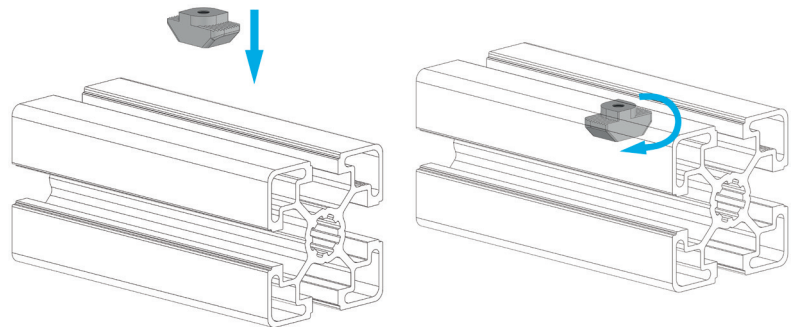
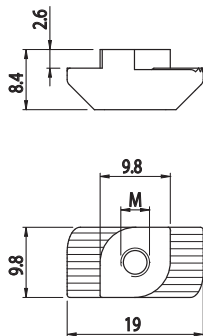

**T-NUT**

DADO A MARTELLO
TUERCA EN T
ÉCROU À TÊTE MARTEAU
HAMMERMUTTER

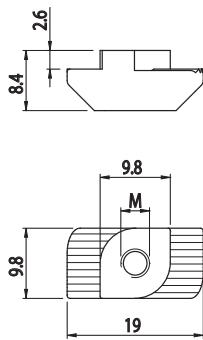
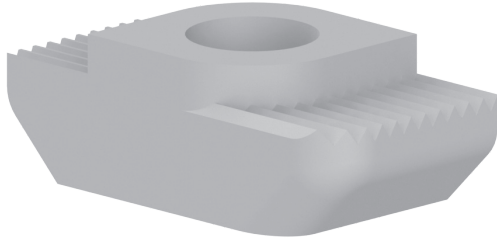

STAINLESS STEEL

BH 105 50	BH 105 45	BH 105 40
-----------------	-----------------	-----------------

Cod	Note	g
084.302.065	M4	1
084.302.066	M5	1
084.302.067	M6	1
084.302.029	M8	1

Stainless steel

Acciaio inox
Acero inoxidable
Acier inox
Rostfreier Stahl

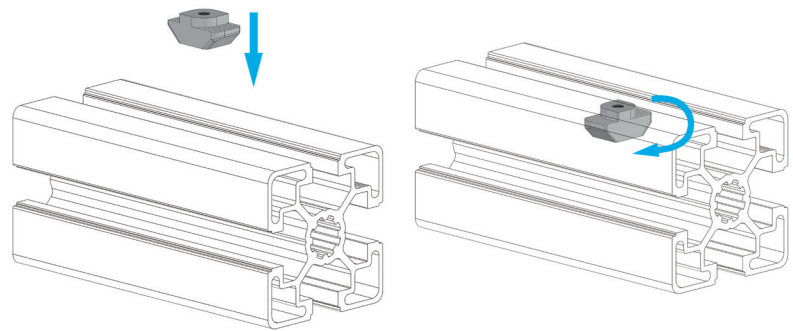
**SLIDING BLOCK**

DADO CON RISALTO
TUERCA EN T
ÉCROU EN T
NUTENSTEIN

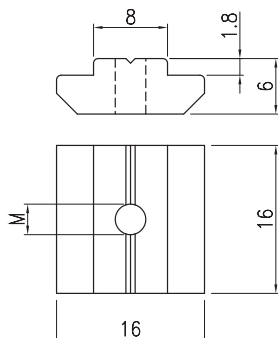
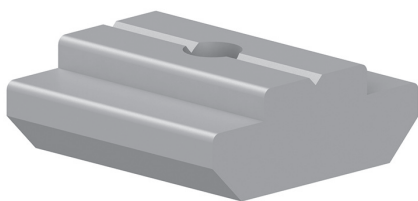

NEW

BH 85 30

Cod	Note	g
084.302.095	M4	20
084.302.096	M5	19
084.302.097	M6	18
084.302.098	M8	17

Galvanised steel

Acciaio zincato
Acero galvanizado
Acier zingué
Verzinkter Stahl

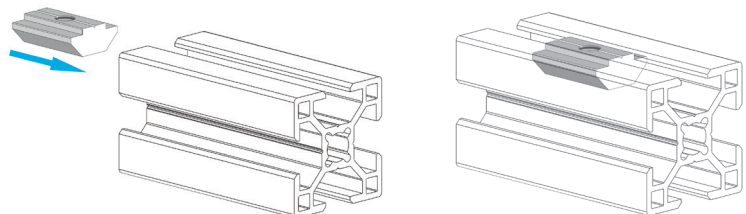



SLIDING BLOCK
DADO CON RISALTO
TUERCA EN T
ÉCROU EN T
NUTENSTEIN

BH 105 50 BH 105 45 BH 105 40

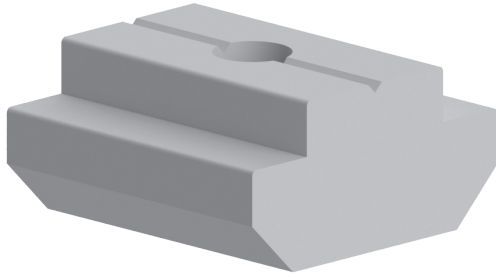

Cod	Note	g
084.302.069	M4	22
084.302.070	M5	21
084.302.071	M6	20
084.302.072	M8	19

Galvanised steel
Acciaio zincato
Acero galvanizado
Acier zingué
Verzinkter Stahl

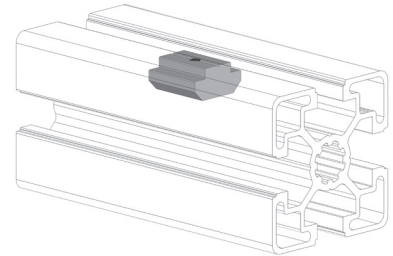
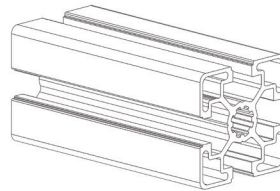
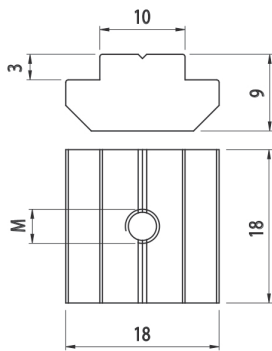

SLIDING BLOCK
DADO CON RISALTO
TUERCA EN T
ÉCROU EN T
NUTENSTEIN

BH 105 50 BH 105 45 BH 105 40

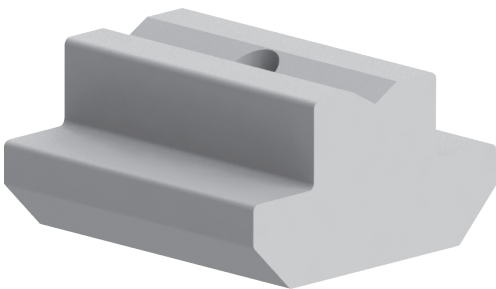

Cod	Note	g
084.302.043	M4	22
084.302.044	M5	21
084.302.045	M6	20
084.302.046	M8	19

Galvanised steel
Acciaio zincato
Acero galvanizado
Acier zingué
Verzinkter Stahl

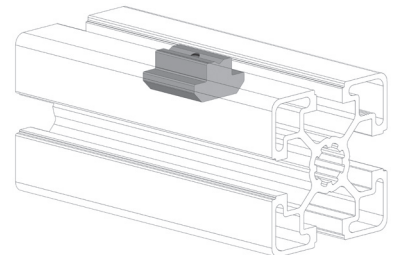
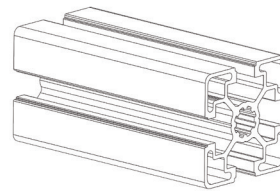
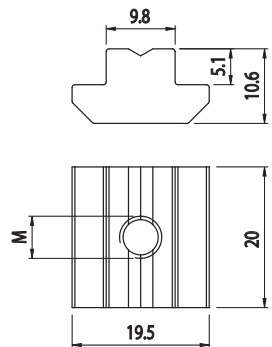

**SWIVEL-IN SLIDING BLOCK WITH SPRING**

DADO CON RISALTO E MOLLA
TUERCA CON MUELLE
ÉCROU À RESSORT
NUTENSTEIN MIT FEDERBLECH

BH
8
30

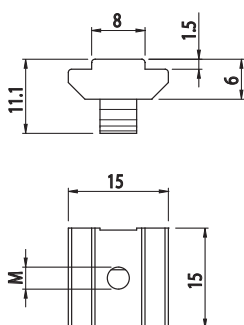
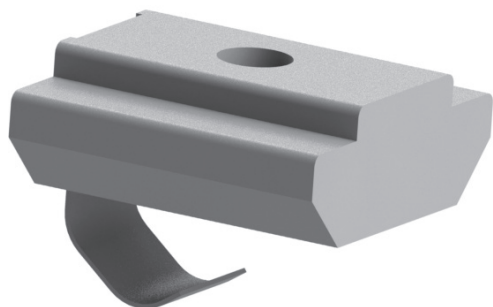

Cod	Note	g
084.302.119	M4	18
084.302.120	M5	17
084.302.121	M6	17
084.302.122	M8	16

Galvanised steel

Acciaio zincato
Acero galvanizado
Acier zingué
Verzinkter Stahl

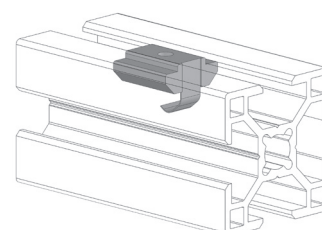
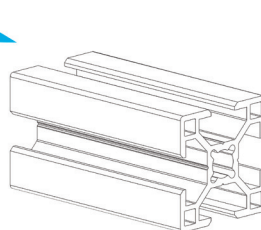
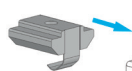
**SWIVEL-IN SLIDING BLOCK WITH SPRING**

DADO CON RISALTO E MOLLA
TUERCA CON MUELLE
ÉCROU À RESSORT
NUTENSTEIN MIT FEDERBLECH

BH
10
50

BH
10
45

BH
10
40

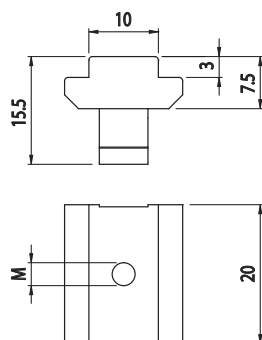
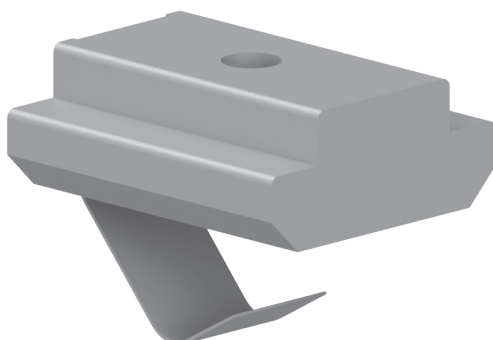

Cod	Note	g
084.302.099	M4	21
084.302.100	M5	20
084.302.101	M6	20
084.302.102	M8	19
084.302.103	M10	18

Galvanised steel

Acciaio zincato
Acero galvanizado
Acier zingué
Verzinkter Stahl

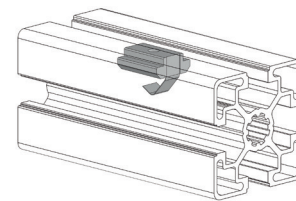
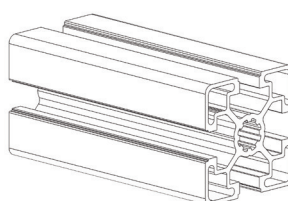



SWIVEL-IN SLIDING BLOCK WITH SPRING

DADO CON RISALTO E MOLLA
TUERCA CON MUELLE
ÉCROU À RESSORT
NUTENSTEIN MIT FEDERBLECH

BH
8
30

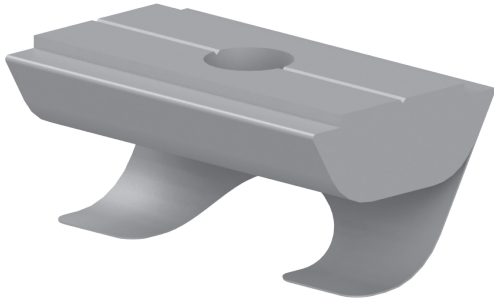

Cod	Note	g
084.302.115	M4	8
084.302.116	M5	8
084.302.117	M6	7
084.302.118	M8	6

Galvanised steel

Acciaio zincato
Acero galvanizado
Acier zingué
Verzinkter Stahl

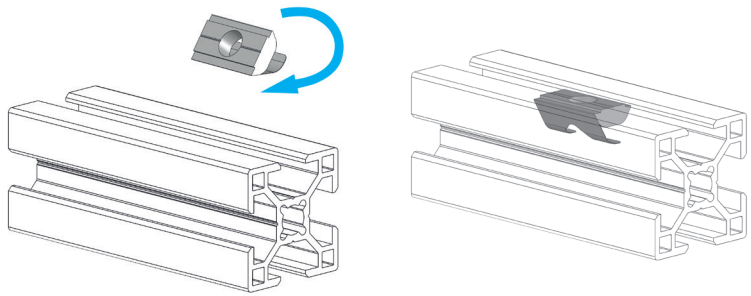
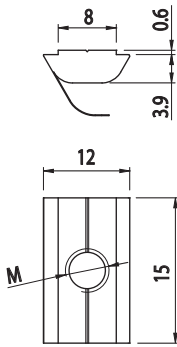

SWIVEL-IN SLIDING BLOCK WITH SPRING

DADO CON RISALTO E MOLLA
TUERCA CON MUELLE
ÉCROU À RESSORT
NUTENSTEIN MIT FEDERBLECH

BH
10
50

BH
10
45

BH
10
40

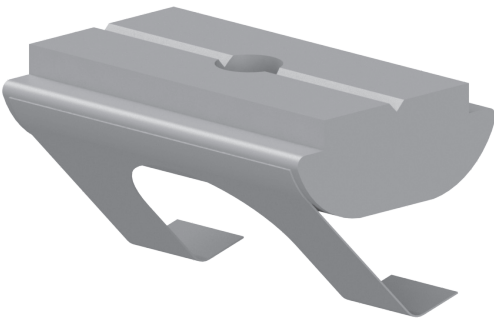

Cod	Note	g
084.302.081	M4	11
084.302.082	M5	10
084.302.083	M6	9
084.302.084	M8	8

Galvanised steel

Acciaio zincato
Acero galvanizado
Acier zingué
Verzinkter Stahl

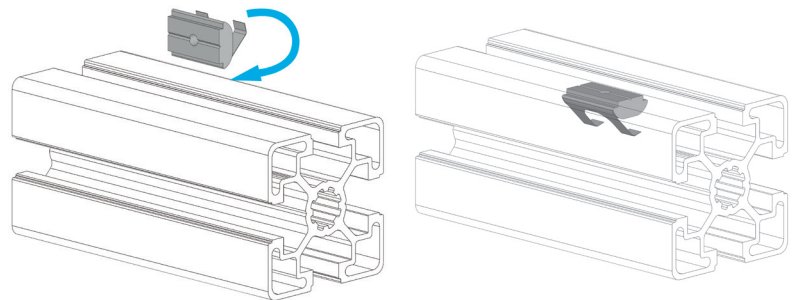
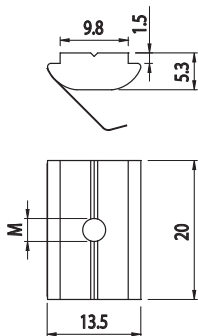

**ROLL-IN NUT WITH BALL**

DADO A CULLA CON SFERA
TUERCA EN FORMA DE CUNA CON BOLA
ÉCROU À BERCEAU AVEC SPHÈRE
WIEGENFÖRMIGE MUTTER MIT KUGEL

BH
6
20

Cod	Note	g
084.302.127	M4	2
084.302.128	M5	2

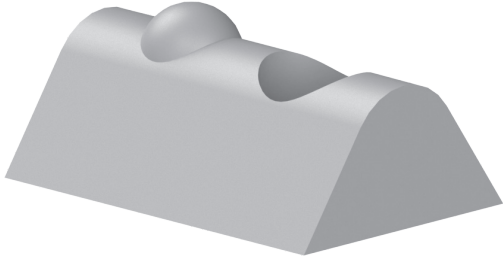
**Galvanised steel**

Acciaio zincato
Acero galvanizado
Acier zingué
Verzinkter Stahl

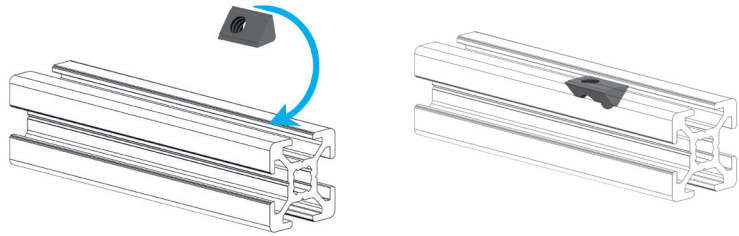
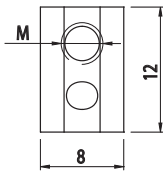
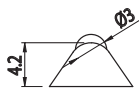
**FLANGE NUT**

DADO FLANGIATO
TUERCA CON COLLAR
ÉCROU À BRIDE
FLANSCHMUTTER

BH
6
20

Cod	Note	g
084.302.036	M8	2

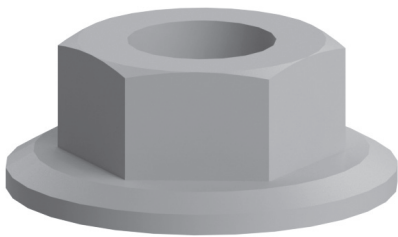
**Galvanised steel**

Acciaio zincato
Acero galvanizado
Acier zingué
Verzinkter Stahl

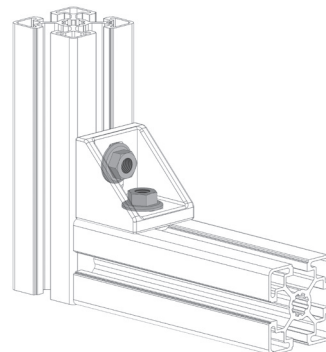
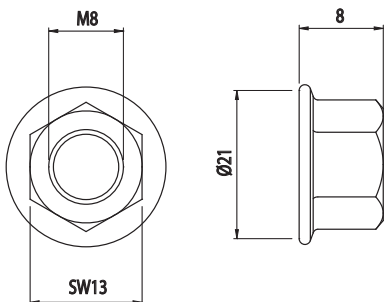



BUSHING
BOCCOLA
CASQUILLO
DOUILLE
BUCHSE

BH 105 50 BH 105 45 BH 105 40

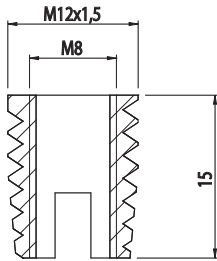
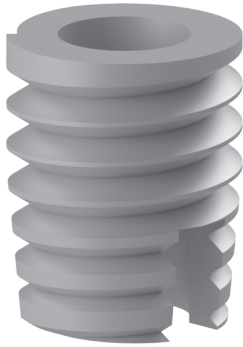

Cod	Note	g
084.312.003	M12/M8	18

Galvanised steel

Acciaio zincato
Acero galvanizado
Acier zingué
Verzinkter Stahl

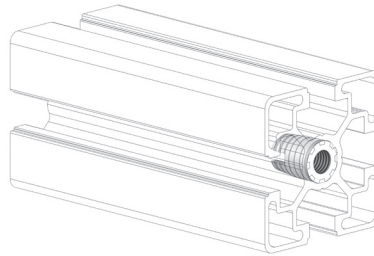

SELF-TAPPING BUSHING
BOCCOLA AUTOFILETTANTE
CASQUILLO AUTORROSCANTE
DOUILLE AUTO-TARAUDEUSE
SELBSTSCHNEIDENDER GEWINDEINSATZ

BH 105 50 BH 105 45 BH 105 40

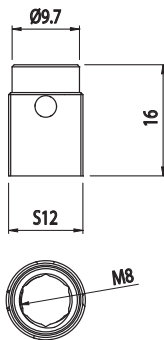

Cod	Note	g
084.312.004	M12/M8	20

Galvanised steel

Acciaio zincato
Acero galvanizado
Acier zingué
Verzinkter Stahl

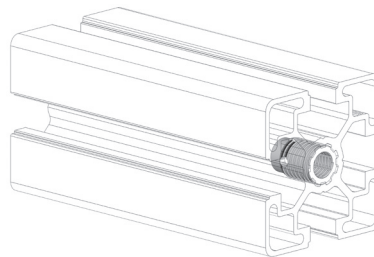

**THREADED BUSHING**

BOCCOLA FILETTATA
CASQUILLO ROSCADO
DOUILLE FILETÉE
GEWINDEBUCHSE

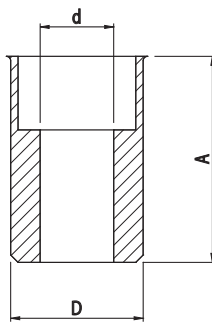

Cod	Note	d	A	D	B	s	g
084.312.007	-	M5	11,50	7	-	-	2
084.312.005	-	M6	14	9	-	-	2
084.312.006	-	M8	16,50	11	-	-	4

Galvanised steel

Acciaio zincato
Acero galvanizado
Acier zingué
Verzinkter Stahl

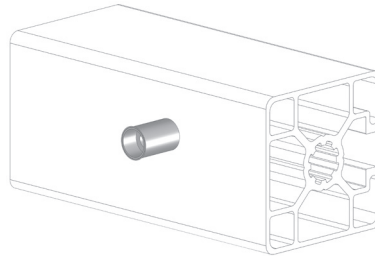



SQUARE WASHER
RONDELLA QUADRA
ARANDELA CUADRADA
RONDELLA QUADRA
VIERKANTSCHIEBE

BH
8
30

Cod	Note	g
084.303.007	16x16	1



Galvanised steel
Acciaio zincato
Acero galvanizado
Acier zingué
Verzinkter Stahl

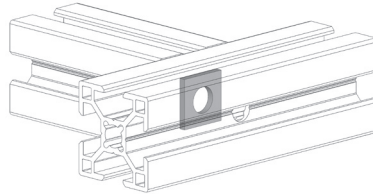
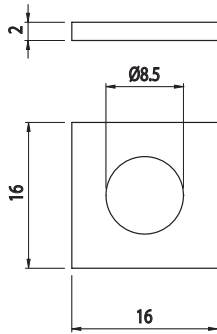

SQUARE WASHER
RONDELLA QUADRA
ARANDELA CUADRADA
RONDELLA QUADRA
VIERKANTSCHIEBE

BH
10
50

BH
10
45

BH
10
40

Cod	Note	g
084.303.004	19x19	1

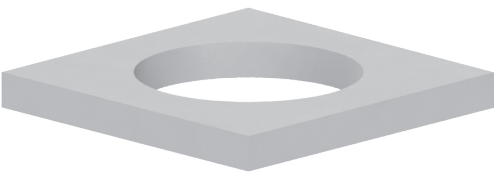

Galvanised steel
Acciaio zincato
Acero galvanizado
Acier zingué
Verzinkter Stahl

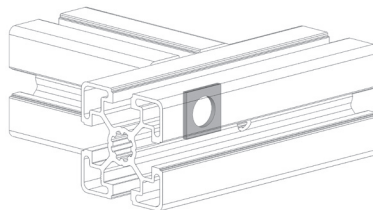
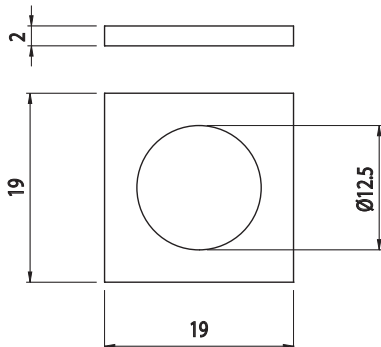



ANTI-ROTATION DEVICE
 DISPOSITIVO ANTIROTAZIONE
 DISPOSITIVO ANTIRROTACIÓN
 DISPOSITIF ANTI-ROTATION
 VERDREHSICHERUNG

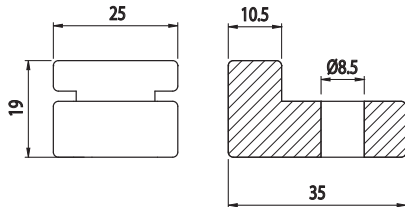
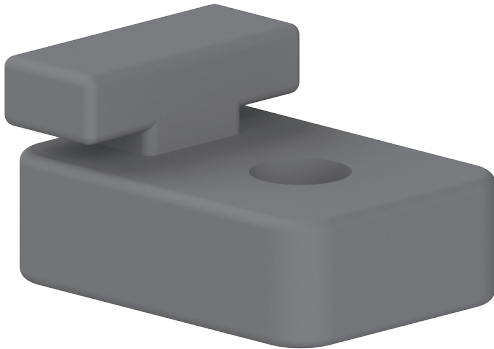

Cod	Note	g
084.303.008	For profile 084.112.002 - Per profilo 084.112.002 - Para perfil 084.112.002 - Pour profilé 084.112.002 - Für Profil 084.112.002	10

Black polyamide
 Poliammide nera
 Poliamida color negro
 Polyamide noir
 Polyamid schwarz

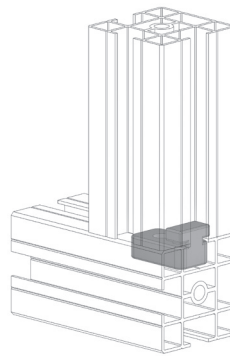



HOLE CLOSER CAP

TAPPO CHIUDI FORO
TAPÓN TAPA-AGUJERO
BOUCHON DE FERMETURE TROU
ABDECKKAPPE FÜR LÖCHER

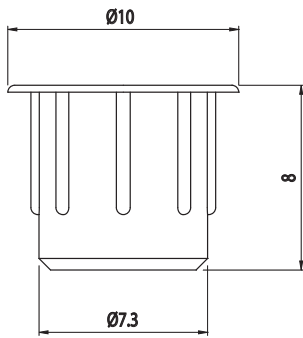

Cod	Note	Color	g
084.202.002	For Ø7.5 mm holes - Per fori Ø7,5 - Para orificios Ø7,5 - Pour trous Ø 7,5 - Für Löcher Ø7,5	■	1
084.202.002N	For Ø7.5 mm holes - Per fori Ø7,5 - Para orificios Ø7,5 - Pour trous Ø 7,5 - Für Löcher Ø7,5	■	1

Polyamide

Poliammide
Poliamida
Polyamide
Polyamid

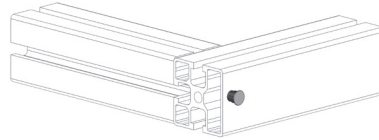

HOLE CLOSER CAP

TAPPO CHIUDI FORO
TAPÓN TAPA-AGUJERO
BOUCHON DE FERMETURE TROU
ABDECKKAPPE FÜR LÖCHER

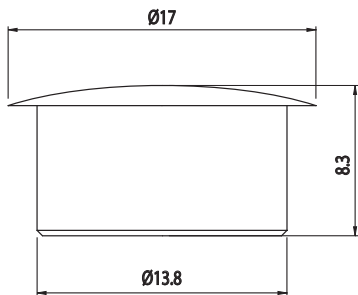
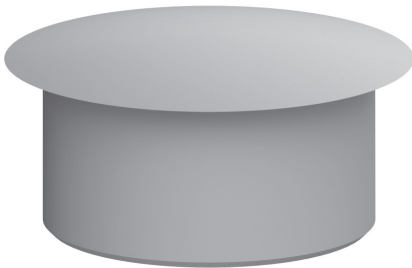

Cod	Note	Color	g
084.202.005	For Ø13 mm holes - Per fori Ø13 - Para orificios Ø13 - Pour trous Ø 13 - Für Löcher Ø13	■	1
084.202.005N	For Ø13 mm holes - Per fori Ø13 - Para orificios Ø13 - Pour trous Ø 13 - Für Löcher Ø13	■	1

Polyamide

Poliammide
Poliamida
Polyamide
Polyamid

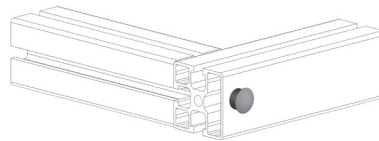

**SCREW CLOSER CAP**

TAPPO CHIUSURA VITE
TAPÓN TAPA-TORNILLO
BOUCHON DE FERMETURE VIS
ABDECKKAPPE FÜR SCHRAUBEN

Cod	Note	g
084.202.006	M6 screw, 4 mm hex socket head - Vite M6 esagono 4 - Tornillo M6 con hexágono de 4 mm - Vis M6 hexagone 4 - Schraube M6 Sechskant 4	1

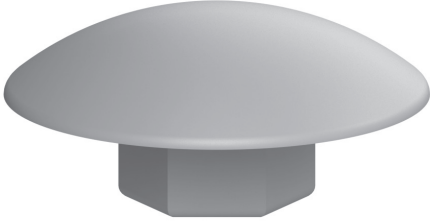
**Grey polyamide**

Poliammide grigia
Poliamida color gris
Polyamide gris
Polyamid grau

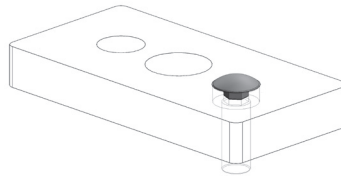
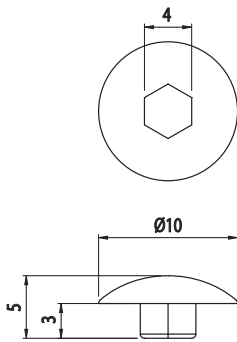
**SCREW CLOSER CAP**

TAPPO CHIUSURA VITE
TAPÓN TAPA-TORNILLO
BOUCHON DE FERMETURE VIS
ABDECKKAPPE FÜR SCHRAUBEN

Cod	Note	g
084.202.009	M6 screw, 5 mm hex socket head - Vite M6 esagono 5 - Tornillo M6 con hexágono de 5 mm - Vis M6 hexagone 5 - Schraube M6 Sechskant 5	1

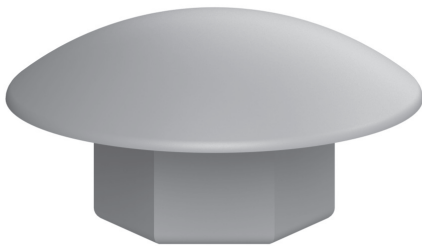
**Grey polyamide**

Poliammide grigia
Poliamida color gris
Polyamide gris
Polyamid grau

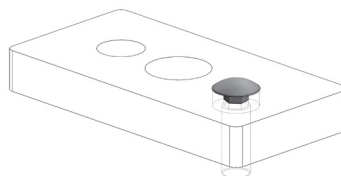
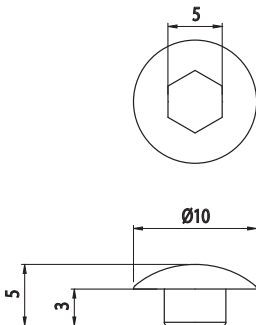



SCREW CLOSER CAP

TAPPO CHIUSURA VITE
TAPÓN TAPA-TORNILLO
BOUCHON DE FERMETURE VIS
ABDECKKAPPE FÜR SCHRAUBEN

Cod	Note	g
084.202.007	M8 screw, 5 mm hex socket head - Vite M8 esagono 5 - Tornillo M8 con hexágono de 5 mm - Vis M8 hexagone 5 - Schraube M8 Sechskant 5	1



Grey polyamide

Poliammide grigia
Poliamida color gris
Polyamide gris
Polyamid grau

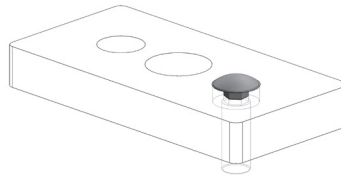
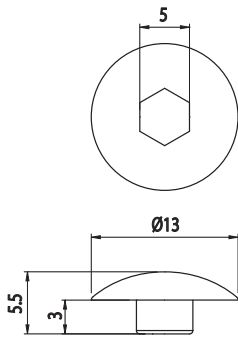

SCREW CLOSER CAP

TAPPO CHIUSURA VITE
TAPÓN TAPA-TORNILLO
BOUCHON DE FERMETURE VIS
ABDECKKAPPE FÜR SCHRAUBEN

Cod	Note	g
084.202.008	M8 screw, 6 mm hex socket head - Vite M8 esagono 6 - Tornillo M8 con hexágono de 6 mm - Vis M8 hexagone 6 - Schraube M8 Sechskant 6	1

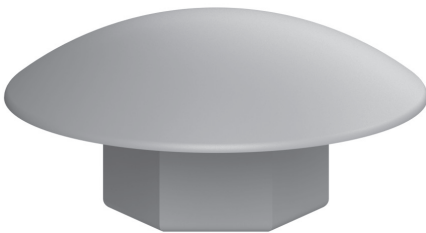

Grey polyamide

Poliammide grigia
Poliamida color gris
Polyamide gris
Polyamid grau

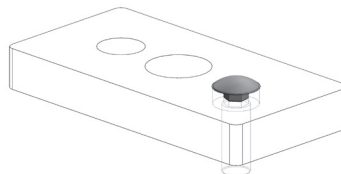
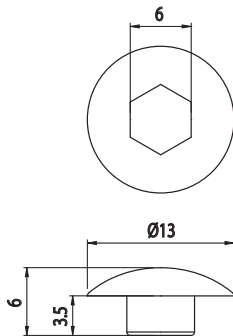

**QUICK CONNECTOR**

NOTTOLINO
RACORD CENTRAL
FIXATION UNIVERSELLE EN T
ZENTRALVERBINDER

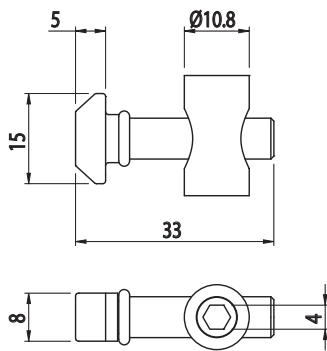
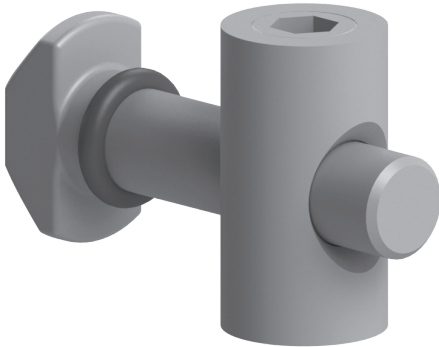
Cod	Note	g
084.306.014	Vertical - Verticale - Vertical - Vertical - Vertikal	19

Galvanised steel

Acciaio zincato
Acero galvanizado
Acier zingué
Verzinkter Stahl

**QUICK CONNECTOR**

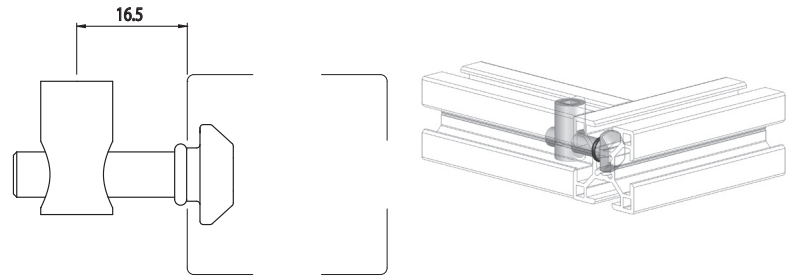
NOTTOLINO
RACORD CENTRAL
FIXATION UNIVERSELLE EN T
ZENTRALVERBINDER

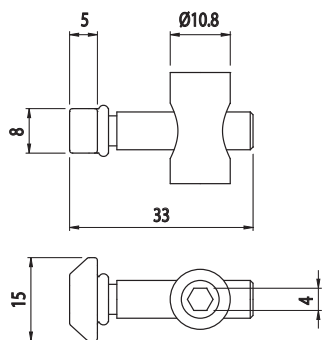
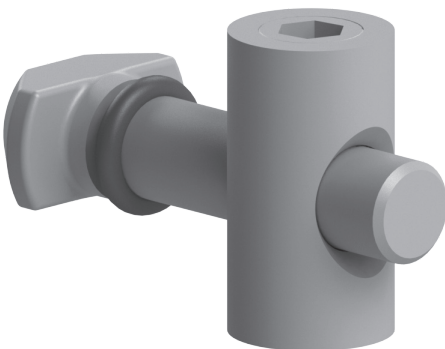
Cod	Note	g
084.306.015	Horizontal - Orizzontale - Horizontal - Horizontal - Horizontal	19

Galvanised steel

Acciaio zincato
Acero galvanizado
Acier zingué
Verzinkter Stahl



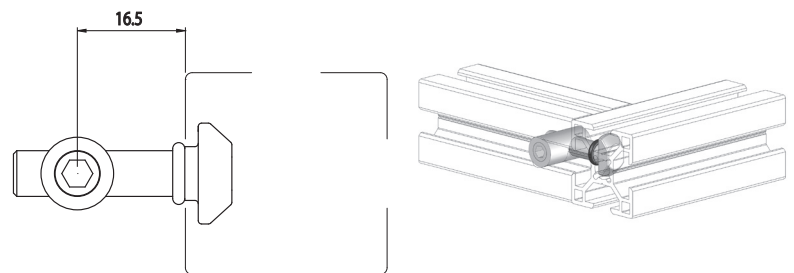

QUICK CONNECTOR

NOTTOLINO
RACORD CENTRAL
FIXATION UNIVERSELLE EN T
ZENTRALVERBINDER

BH 105 50 BH 105 45 BH 105 40

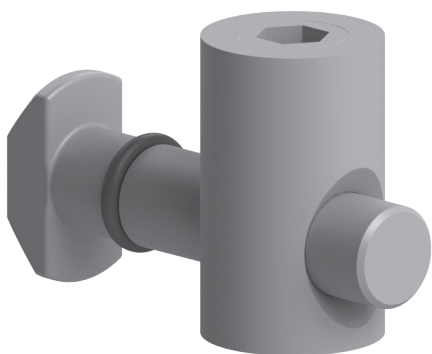

Cod	Note	g
084.306.008	Vertical - Verticale - Vertical - Vertical - Vertikal	49

Galvanised steel

Acciaio zincato
Acero galvanizado
Acier zingué
Verzinkter Stahl

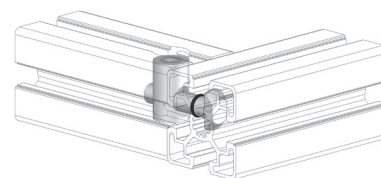
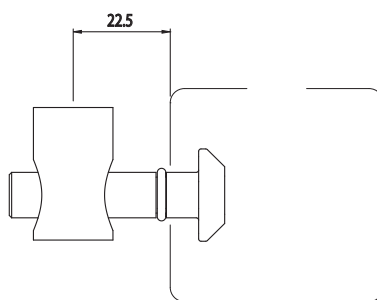
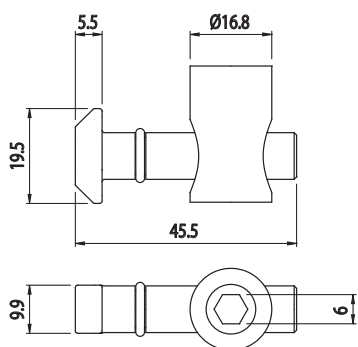

QUICK CONNECTOR

NOTTOLINO
RACORD CENTRAL
FIXATION UNIVERSELLE EN T
ZENTRALVERBINDER

BH 105 50 BH 105 45 BH 105 40

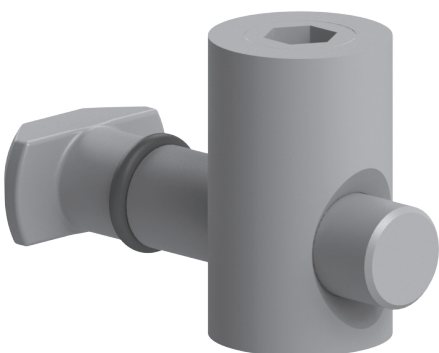

Cod	Note	g
084.306.009	Horizontal - Orizzontale - Horizontal - Horizontal - Horizontal	49

Galvanised steel

Acciaio zincato
Acero galvanizado
Acier zingué
Verzinkter Stahl

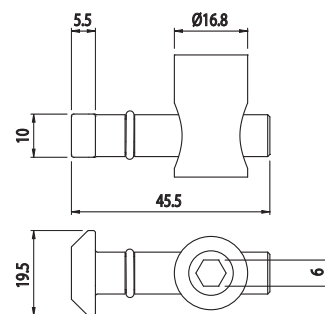
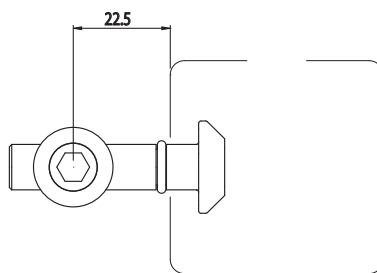
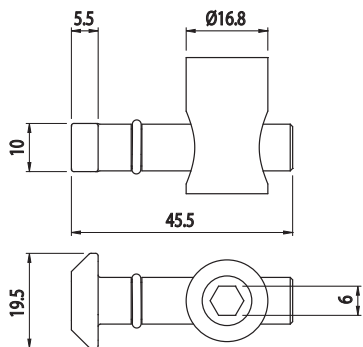

**QUICK CONNECTOR**

NOTTOLINO
RACORD CENTRAL
FIXATION UNIVERSELLE EN T
ZENTRALVERBINDER

BH 105 50 BH 105 45 BH 105 40

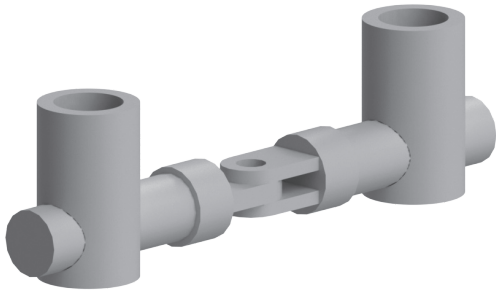

Cod	Note	g
084.306.017	Horizontally articulated - Snodabile orizzontale - Articulable horizontal - Articulable horizontal - Verstellbar, horizontal	89

Galvanised steel

Acciaio zincato
Acero galvanizado
Acier zingué
Verzinkter Stahl

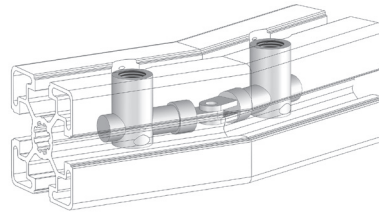
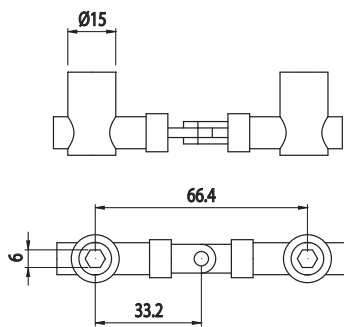
**QUICK CONNECTOR**

NOTTOLINO
RACORD CENTRAL
FIXATION UNIVERSELLE EN T
ZENTRALVERBINDER

BH 105 50 BH 105 45 BH 105 40

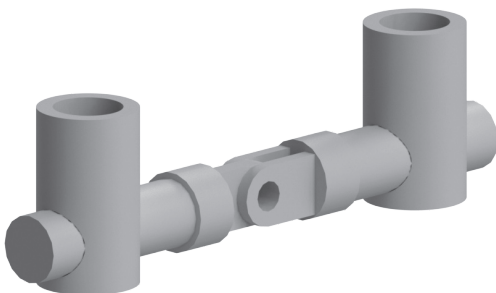

Cod	Note	g
084.306.018	Vertically articulated - Snodabile verticale - Arti- culable vertical - Articulable vertical - Verstellbar, vertikal	89

Galvanised steel

Acciaio zincato
Acero galvanizado
Acier zingué
Verzinkter Stahl

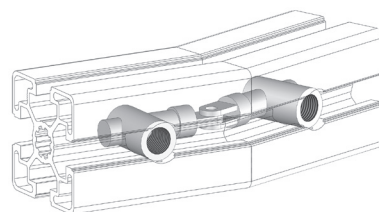
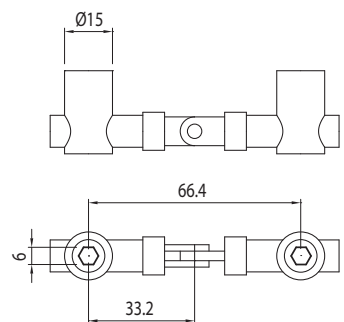



MILLING CONNECTOR

RACCORDO 90°
RACOR 90°
RACCORD 90°
FRÄSVERBINDER



Cod	Note	g
084.306.013	Connector in slot - Raccordo in cava - Racor en ranura - Raccord dans rainure - Verbindungsstück in Nut	39

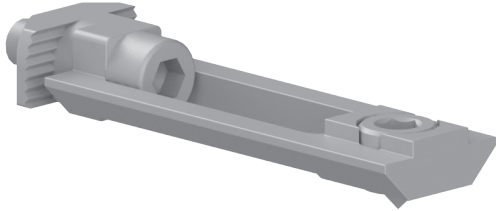

Galvanised steel

Acciaio zincato
Acero galvanizado
Acier zingué
Verzinkter Stahl

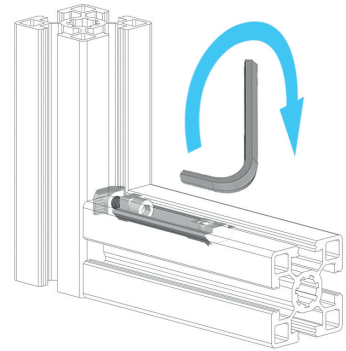
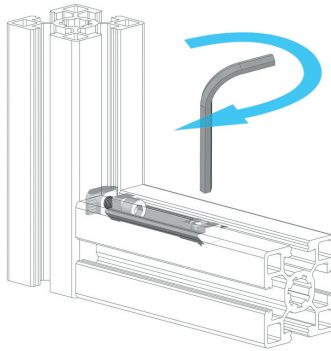
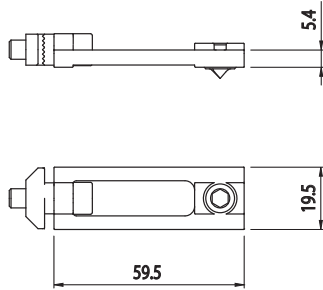

30° MITER CONNECTOR

GIUNTO ANGOLARE 30°
ESCUADRA 30°
EQUERRE INTERNE 30°
GEHRUNGSVERBINDER 30°



Cod	Note	g
084.307.039	Complete with 4 x M5x5 grub screws - Completo di 4 grani M5x5 - Incluye 4 tornillos sin cabeza M5x5 - Avec 4 pions M5x5 - Einschließlich 4 Stifte M5x5	11

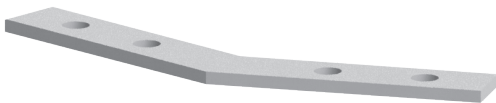

Galvanised steel

Acciaio zincato
Acero galvanizado
Acier zingué
Verzinkter Stahl

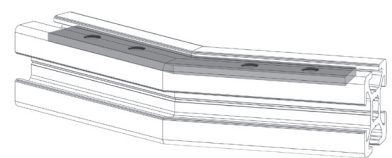
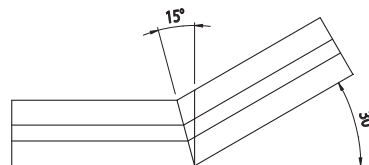
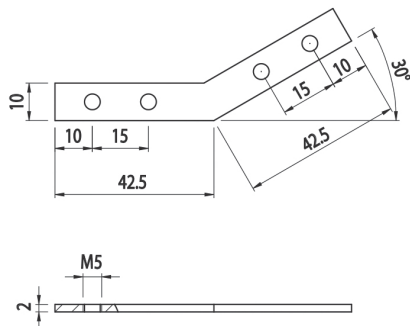

**45° MITER CONNECTOR**

GIUNTO ANGOLARE 45°
 ESCUADRA 45°
 EQUERRE INTERNE 45°
 GEHRUNGSVERBINDER 45°



Cod	Note	g
084.307.040	Complete with 4 x M5x5 grub screws - Completo di 4 grani M5x5 - Incluye 4 tornillos sin cabeza M5x5 - Avec 4 pions M5x5 - Einschließlich 4 Stifte M5x5	11

**Galvanised steel**

Acciaio zincato
 Acero galvanizado
 Acier zingué
 Verzinkter Stahl

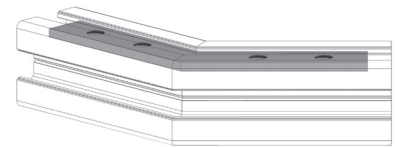
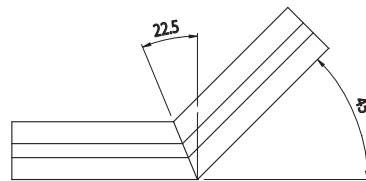
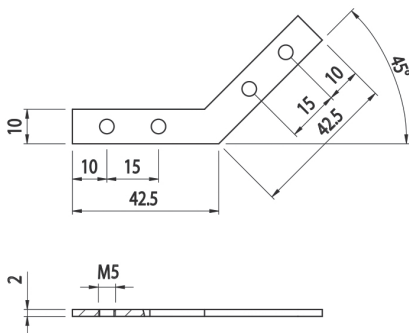
**60° MITER CONNECTOR**

GIUNTO ANGOLARE 60°
 ESCUADRA 60°
 EQUERRE INTERNE 60°
 GEHRUNGSVERBINDER 60°



Cod	Note	g
084.307.041	Complete with 4 x M5x5 grub screws - Completo di 4 grani M5x5 - Incluye 4 tornillos sin cabeza M5x5 - Avec 4 pions M5x5 - Einschließlich 4 Stifte M5x5	11

**Galvanised steel**

Acciaio zincato
 Acero galvanizado
 Acier zingué
 Verzinkter Stahl

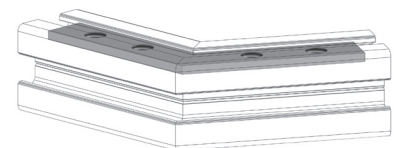
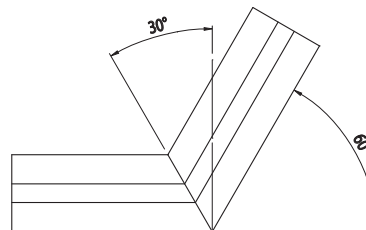
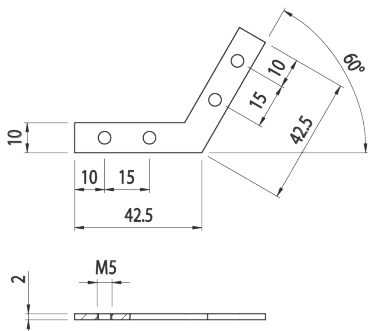



90° MITER CONNECTOR

GIUNTO ANGOLARE 90°
ESCUADRA 90°
EQUERRE INTERNE 90°
GEHRUNGSVERBINDER 90°



Cod	Note	g
084.307.042	Complete with 4 x M5x5 grub screws - Completo di 4 grani M5x5 - Incluye 4 tornillos sin cabeza M5x5 - Avec 4 pions M5x5 - Einschließlich 4 Stifte M5x5	11



Galvanised steel

Acciaio zincato
Acero galvanizado
Acier zingué
Verzinkter Stahl

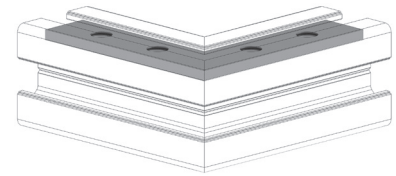
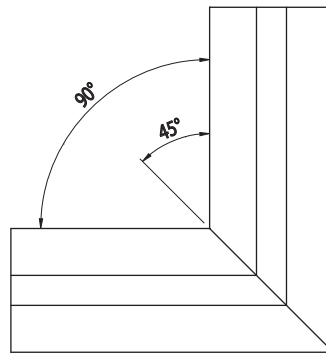
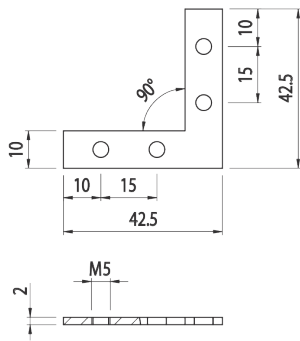

30° MITER CONNECTOR

GIUNTO ANGOLARE 30°
ESCUADRA 30°
EQUERRE INTERNE 30°
GEHRUNGSVERBINDER 30°



Cod	Note	g
084.307.043	Complete with 4 x M6x8 grub screws - Completo di 4 grani M6x8 - Incluye 4 tornillos sin cabeza M6x8 - Avec 4 pions M6x8 - Einschließlich 4 Stifte M6x8	38

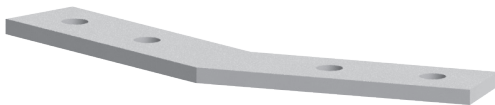

Galvanised steel

Acciaio zincato
Acero galvanizado
Acier zingué
Verzinkter Stahl

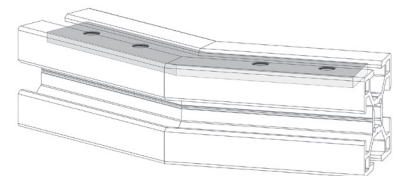
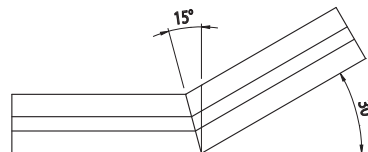
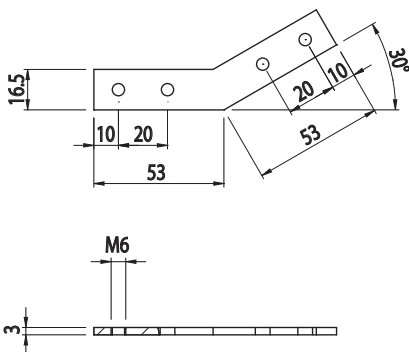

**45° MITER CONNECTOR**

GIUNTO ANGOLARE 45°
 ESCUADRA 45°
 EQUERRE INTERNE 45°
 GEHRUNGSVERBINDER 45°

BH 105 40	BH 85 30
-----------------	----------------

Cod	Note	g
084.307.044	Complete with 4 x M6x8 grub screws - Completo di 4 grani M6x8 - Incluye 4 tornillos sin cabeza M6x8 - Avec 4 pions M6x8 - Einschließlich 4 Stifte M6x8	38

**Galvanised steel**

Acciaio zincato
 Acero galvanizado
 Acier zingué
 Verzinkter Stahl

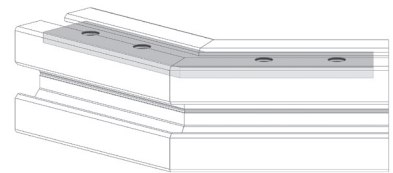
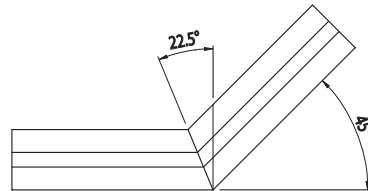
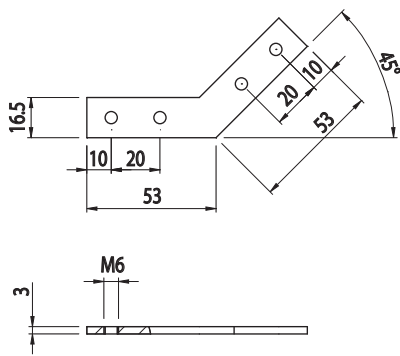
**60° MITER CONNECTOR**

GIUNTO ANGOLARE 60°
 ESCUADRA 60°
 EQUERRE INTERNE 60°
 GEHRUNGSVERBINDER 60°

BH 105 40	BH 85 30
-----------------	----------------

Cod	Note	g
084.307.045	Complete with 4 x M6x8 grub screws - Completo di 4 grani M6x8 - Incluye 4 tornillos sin cabeza M6x8 - Avec 4 pions M6x8 - Einschließlich 4 Stifte M6x8	38

**Galvanised steel**

Acciaio zincato
 Acero galvanizado
 Acier zingué
 Verzinkter Stahl

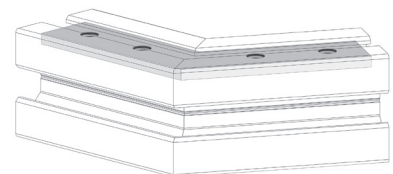
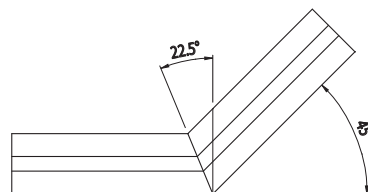
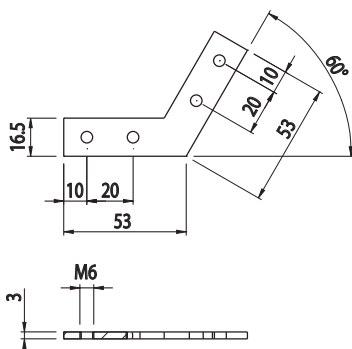



90° MITER CONNECTOR

GIUNTO ANGOLARE 90°
ESCUADRA 90°
EQUERRE INTERNE 90°
GEHRUNGSVERBINDER 90°



Cod	Note	g
084.307.046	Complete with 4 x M6x8 grub screws - Completo di 4 grani M6x8 - Incluye 4 tornillos sin cabeza M6x8 - Avec 4 pions M6x8 - Einschließlich 4 Stifte M6x8	38

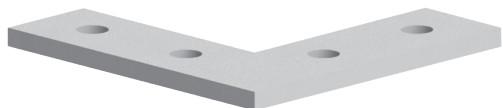

Galvanised steel

Acciaio zincato
Acero galvanizado
Acier zingué
Verzinkter Stahl

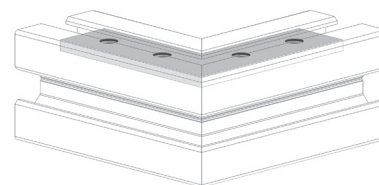
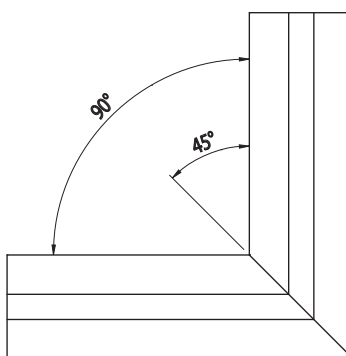
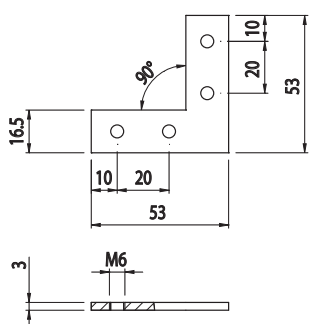

30° MITER CONNECTOR

GIUNTO ANGOLARE 30°
ESCUADRA 30°
EQUERRE INTERNE 30°
GEHRUNGSVERBINDER 30°

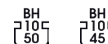

Cod	Note	g
084.307.047	Complete with 4 x M8x12 grub screws - Completo di 4 grani M8x12 - Incluye 4 tornillos sin cabeza M8x12 - Avec 4 pions M8x12 - Einschließlich 4 Stifte M8x12	36



Galvanised steel

Acciaio zincato
Acero galvanizado
Acier zingué
Verzinkter Stahl

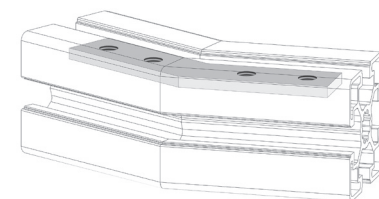
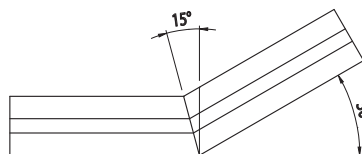
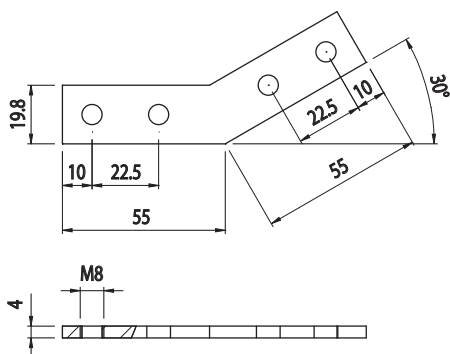

**45° MITER CONNECTOR**

GIUNTO ANGOLARE 45°
 ESCUADRA 45°
 EQUERRE INTERNE 45°
 GEHRUNGSVERBINDER 45°

BH 105 50 BH 105 45

Cod	Note	g
084.307.048	Complete with 4 x M8x12 grub screws - Completo di 4 grani M8x12 - Incluye 4 tornillos sin cabeza M8x12 - Avec 4 pions M8x12 - Einschließlich 4 Stifte M8x12	36

**Galvanised steel**

Acciaio zincato
 Acero galvanizado
 Acier zingué
 Verzinkter Stahl

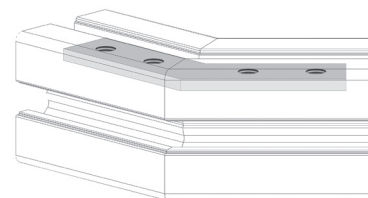
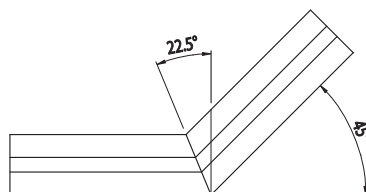
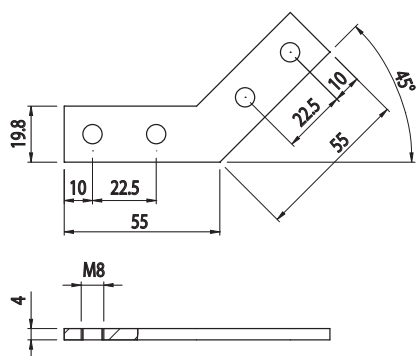
**60° MITER CONNECTOR**

GIUNTO ANGOLARE 60°
 ESCUADRA 60°
 EQUERRE INTERNE 60°
 GEHRUNGSVERBINDER 60°

BH 105 50 BH 105 45

Cod	Note	g
084.307.049	Complete with 4 x M8x12 grub screws - Completo di 4 grani M8x12 - Incluye 4 tornillos sin cabeza M8x12 - Avec 4 pions M8x12 - Einschließlich 4 Stifte M8x12	36

**Galvanised steel**

Acciaio zincato
 Acero galvanizado
 Acier zingué
 Verzinkter Stahl

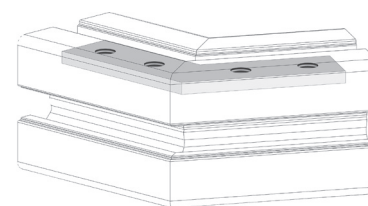
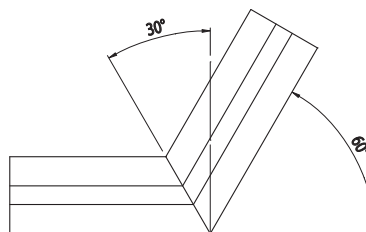
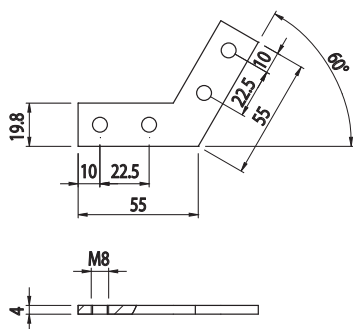



90° MITER CONNECTOR

GIUNTO ANGOLARE 90°
ESCUADRA 90°
EQUERRE INTERNE 90°
GEHRUNGSVERBINDER 90°



Cod	Note	g
084.307.050	Complete with 4 x M8x12 grub screws - Completo di 4 grani M8x12 - Incluye 4 tornillos sin cabeza M8x12 - Avec 4 pions M8x12 - Einschließlich 4 Stifte M8x12	36

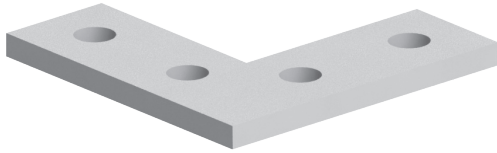

Galvanised steel

Acciaio zincato
Acero galvanizado
Acier zingué
Verzinkter Stahl

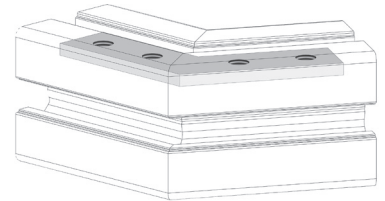
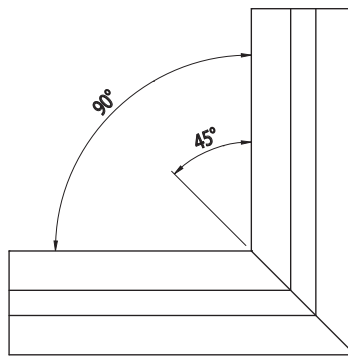
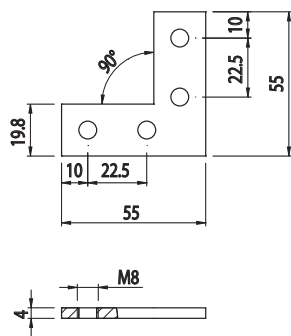

**100 mm PROFILE CONNECTOR**

GIUNTO LINEARE 100 mm
EMPALME LINEAL 100 mm
JOINT LINÉAIRE 100 mm
STRECKENVERBINDER 100 mm

BH
65
20

Cod	Note	g
084.307.037	Complete with 4 x M5 grub screws - Completo di 4 grani M5 - Incluye 4 tornillos sin cabeza M5 - Avec 4 pions M5 - Einschließlich 4 Stifte M5	27

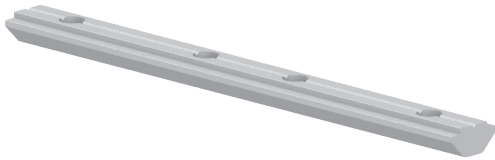
**Galvanised steel**

Acciaio zincato
Acero galvanizado
Acier zingué
Verzinkter Stahl

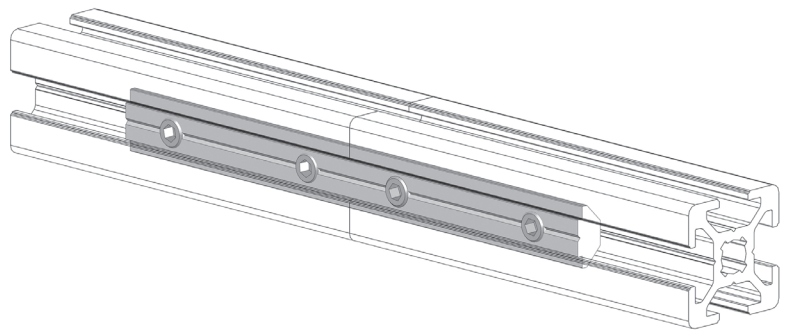
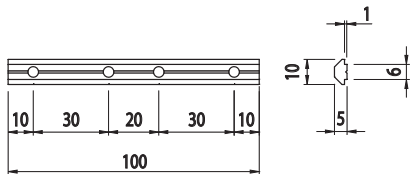
**180 mm PROFILE CONNECTOR**

GIUNTO LINEARE 180 mm
EMPALME LINEAL 180 mm
JOINT LINÉAIRE 180 mm
STRECKENVERBINDER 180 mm

BH
85
30

Cod	Note	g
084.307.051	Complete with 4 x M5 grub screws - Completo di 4 grani M5 - Incluye 4 tornillos sin cabeza M5 - Avec 4 pions M5 - Einschließlich 4 Stifte M5	27

**Galvanised steel**

Acciaio zincato
Acero galvanizado
Acier zingué
Verzinkter Stahl

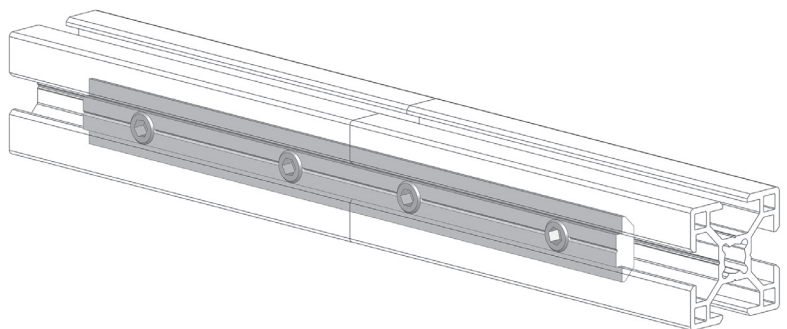
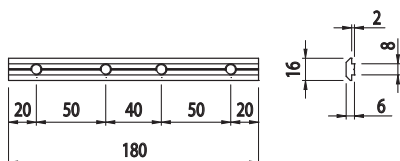



90 mm PROFILE CONNECTOR

GIUNTO LINEARE 90 mm
EMPALME LINEAL 90 mm
JOINT LINÉAIRE 90 mm
STRECKENVERBINDER 90 mm



Cod	Note	g
084.307.024	Complete with 4 x M8 grub screws - Completo di 4 grani M8 - Incluye 4 tornillos sin cabeza M8 - Avec 4 pions M8 - Einschließlich 4 Stifte M8	80

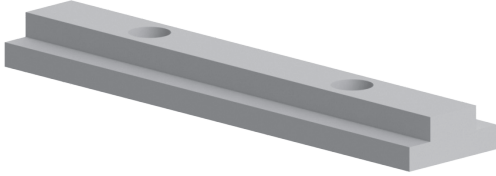

Galvanised steel

Acciaio zincato
Acero galvanizado
Acier zingué
Verzinkter Stahl

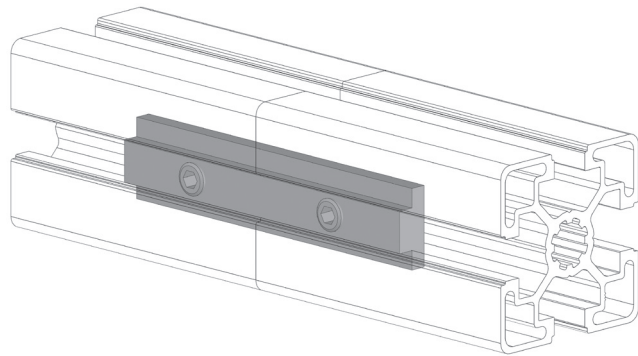
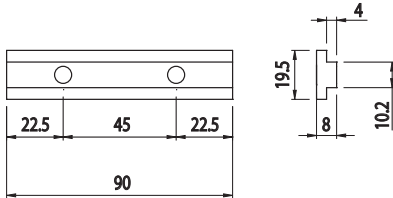

180 mm PROFILE CONNECTOR

GIUNTO LINEARE 180 mm
EMPALME LINEAL 180 mm
JOINT LINÉAIRE 180 mm
STRECKENVERBINDER 180 mm



Cod	Note	g
084.307.025	Complete with 4 x M8 grub screws - Completo di 4 grani M8 - Incluye 4 tornillos sin cabeza M8 - Avec 4 pions M8 - Einschließlich 4 Stifte M8	160

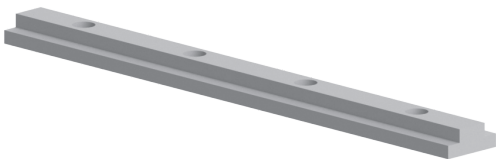

Galvanised steel

Acciaio zincato
Acero galvanizado
Acier zingué
Verzinkter Stahl

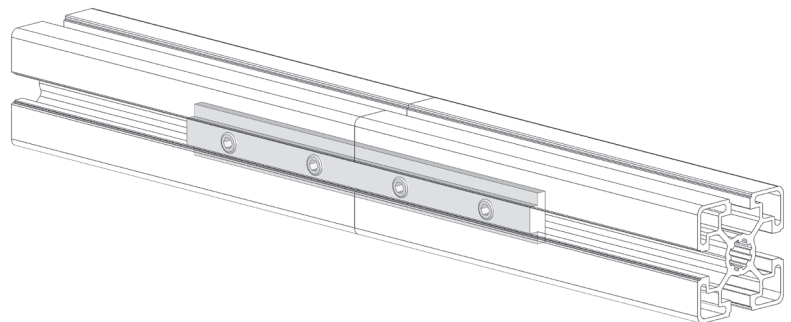
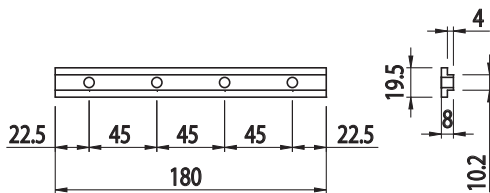

**CONNECTION PLATE**

PIASTRA DI GIUNZIONE
PLACA DE ACOPLAMIENTO
PLATINE D'ASSEMBLAGE
VERBINDERPLATTE

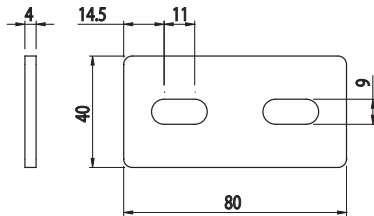
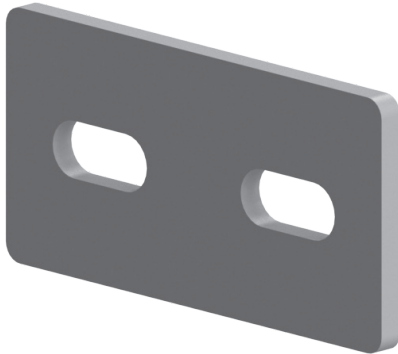

Cod	Note	g
084.710.002	For 40x40 and 45x45 profiles - Per profili 40x40 e 45x45 - Para perfiles 40x40 y 45x45 - Pour profilés 40x40 et 45x45 - Für Profile 40x40 und 45x45	88

Galvanised steel

Acciaio zincato
Acero galvanizado
Acier zingué
Verzinkter Stahl

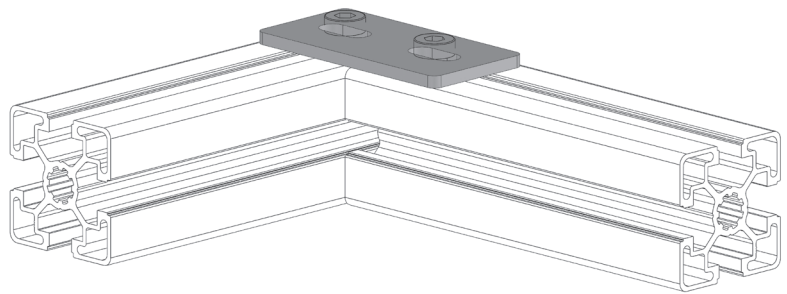
**CONNECTION PLATE**

PIASTRA DI GIUNZIONE
PLACA DE ACOPLAMIENTO
PLATINE D'ASSEMBLAGE
VERBINDERPLATTE

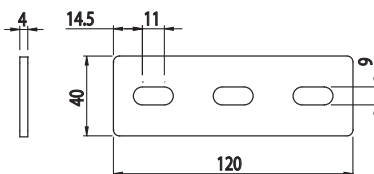
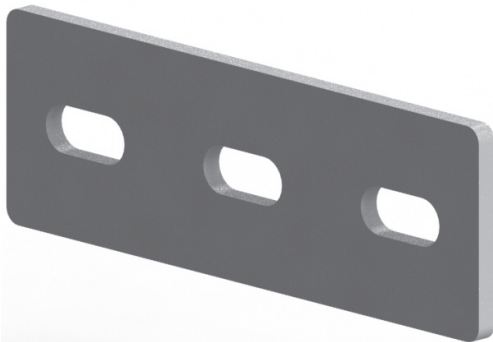

Cod	Note	g
084.710.004	For 40x40 and 45x45 profiles - Per profili 40x40 e 45x45 - Para perfiles 40x40 y 45x45 - Pour profilés 40x40 et 45x45 - Für Profile 40x40 und 45x45	132

Galvanised steel

Acciaio zincato
Acero galvanizado
Acier zingué
Verzinkter Stahl

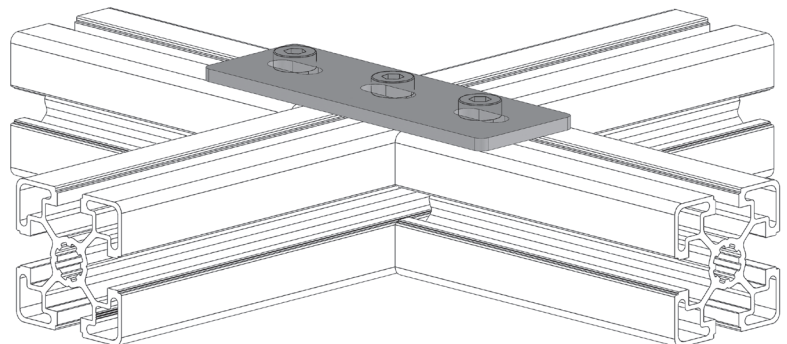



CONNECTION PLATE
PIASTRA DI GIUNZIONE
PLACA DE ACOPLAMIENTO
PLATINE D'ASSEMBLAGE
VERBINDERPLATTE

BH
7105
40

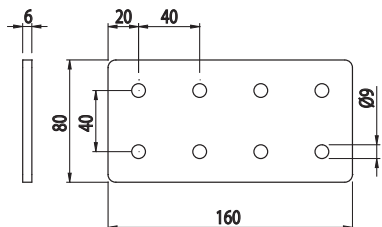
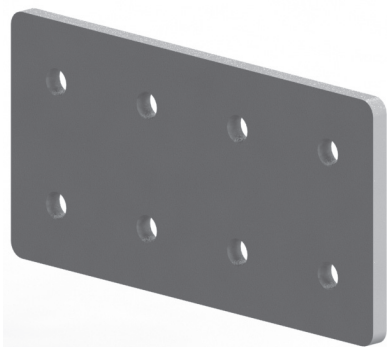

Cod	Note	g
084.710.003	For 40x80 and 80x80 profiles - Per profili 40x80 e 80x80 - Para perfiles 40x80 y 80x80 - Pour profilés 40x80 et 80x80 - Für Profile 40x80 und 80x80	730

Galvanised steel
Acciaio zincato
Acero galvanizado
Acier zingué
Verzinkter Stahl

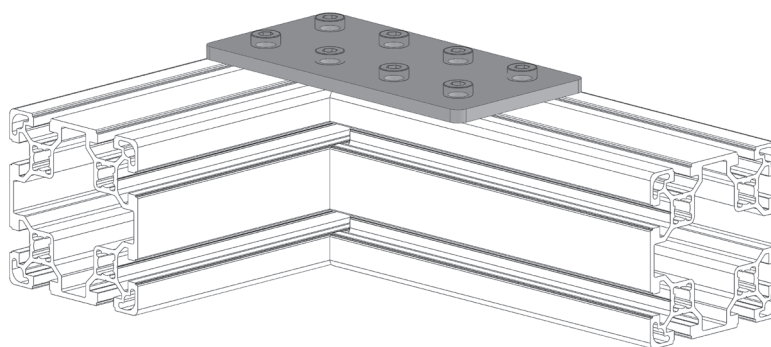

CONNECTION PLATE
PIASTRA DI GIUNZIONE
PLACA DE ACOPLAMIENTO
PLATINE D'ASSEMBLAGE
VERBINDERPLATTE

BH
7105
40

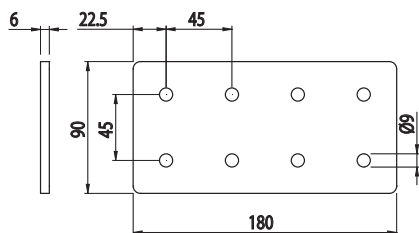
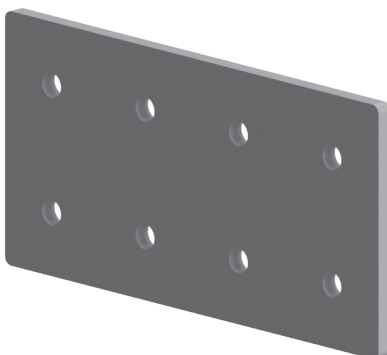

Cod	Note	g
084.710.001	For 45x90 and 90x90 profiles - Per profili 45x90 e 90x90 - Para perfiles 45x90 y 90x90 - Pour profilés 45x90 et 90x90 - Für Profile 45x90 und 90x90	730

Galvanised steel
Acciaio zincato
Acero galvanizado
Acier zingué
Verzinkter Stahl

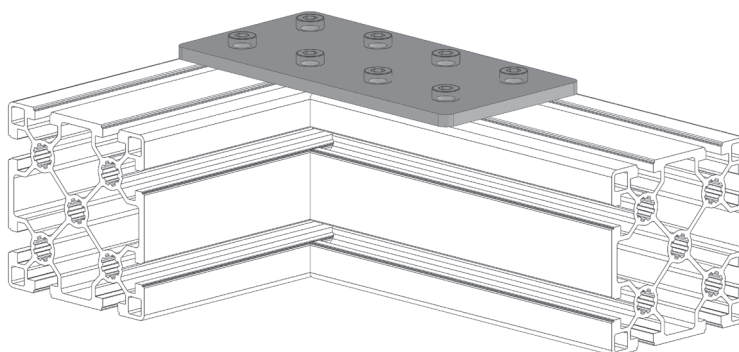

**CONNECTION PLATE**

PIASTRA DI GIUNZIONE
PLACA DE ACOPLAMIENTO
PLATINE D'ASSEMBLAGE
VERBINDERPLATTE

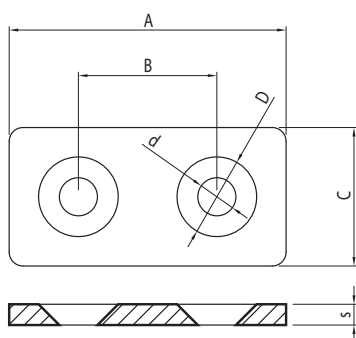
**NEW**

BH 6 20	BH 8 30	BH 10 40	BH 10 45
---------------	---------------	----------------	----------------

Cod	Note	A	B	C	D	d	s	g
084.710.006N	20x20	40	20	20	11,5	5,5	3	16
084.710.007N	30x30	60	30	30	13	7	3	38
084.710.008N	40x40	80	40	40	18	9,2	4	90
084.710.009N	45x45	90	45	45	19,2	9,2	5	145

Black painted steel

Acciaio verniciato nero
Acero barnizado en negro
Acier peint noir
Stahl schwarz lackiert

Cod	Note	A	B	C	D	d	s	g
084.710.006G	20x20	40	20	20	11,5	5,5	3	16
084.710.007G	30x30	60	30	30	13	7	3	38
084.710.008G	40x40	80	40	40	18	9,2	4	90
084.710.009G	45x45	90	45	45	19,2	9,2	5	145

Grey painted steel

Acciaio verniciato grigio
Acero barnizado en gris
Acier peint gris
Stahl grau lackiert

Cod	Note	A	B	C	D	d	s	g
084.710.006ZN	20x20	40	20	20	11,5	5,5	3	16
084.710.007ZN	30x30	60	30	30	13	7	3	38
084.710.008ZN	40x40	80	40	40	18	9,2	4	90
084.710.009ZN	45x45	90	45	45	19,2	9,2	5	145

Galvanised steel

Acciaio zincato
Acero galvanizado
Acier zingué
Verzinkter Stahl

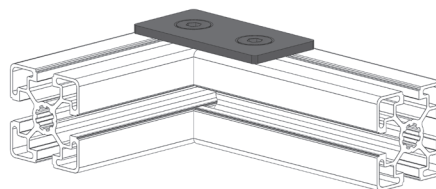



INNER BRACKET
GIUNTO INTERNO
ESCUADRA INTERNA
EQUERRE INTERNE
INNENVERBINDER

BH
6
20

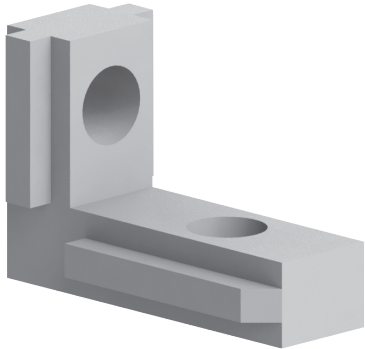

Cod	Note	g
084.307.036	Complete with 2 x M5 grub screws - Completo di 2 grani M5 - Incluye 2 tornillos sin cabeza M5 - Avec 2 pions M5 - Einschließlich 2 Stifte M5	6,50

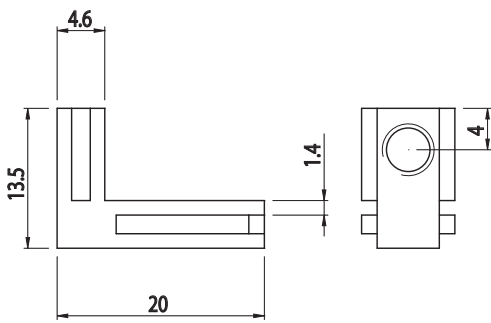

Galvanised steel
Acciaio zincato
Acero galvanizado
Acier zingué
Verzinkter Stahl

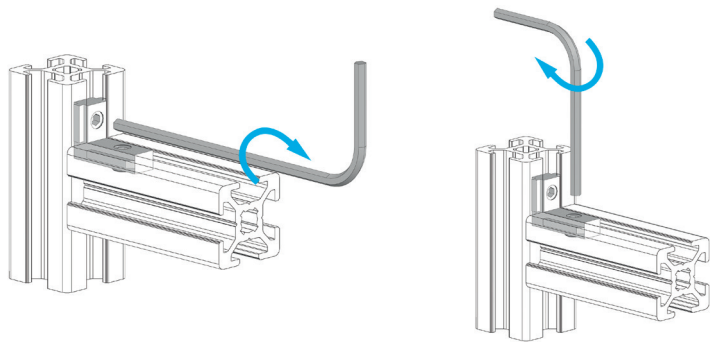

INNER BRACKET
GIUNTO INTERNO
ESCUADRA INTERNA
EQUERRE INTERNE
INNENVERBINDER

BH
8
30

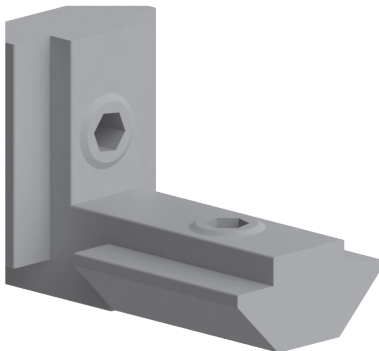

Cod	Note	g
084.307.052	Complete with 2 grub screws - Completo di 2 grani - Incluye 2 tornillos sin cabeza - Avec 2 pions - Einschließlich 2 Stifte	22

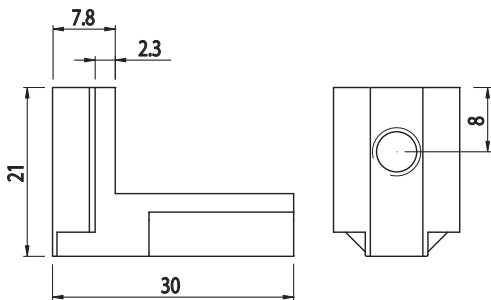

Galvanised steel
Acciaio zincato
Acero galvanizado
Acier zingué
Verzinkter Stahl

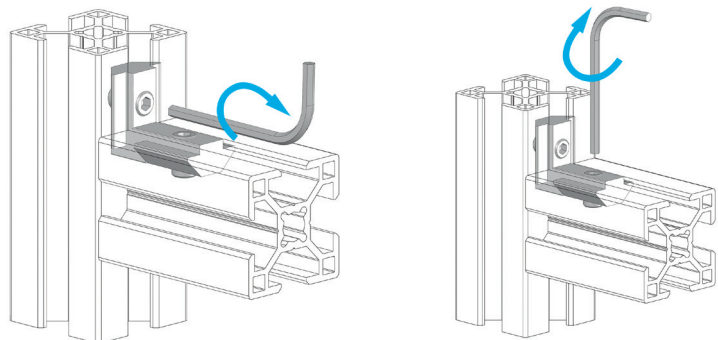



INNER BRACKET
GIUNTO INTERNO
ESCUADRA INTERNA
EQUERRE INTERNE
INNENVERBINDER

BH 105 50 BH 105 45 BH 105 40

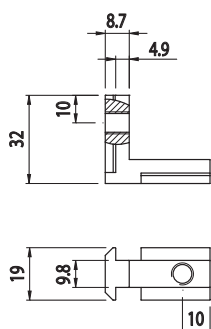
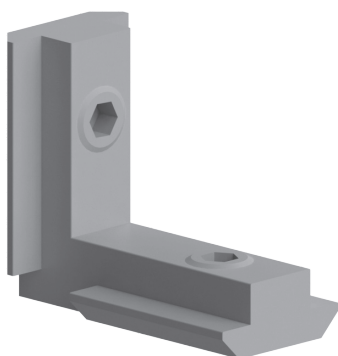

Cod	Note	g
084.307.053	Complete with 2 grub screws - Completo di 2 grani - Incluye 2 tornillos sin cabeza - Avec 2 pions - Einschließlich 2 Stifte	40

Galvanised steel

Acciaio zincato
Acero galvanizado
Acier zingué
Verzinkter Stahl

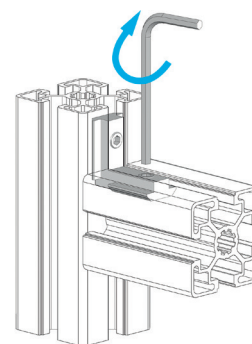
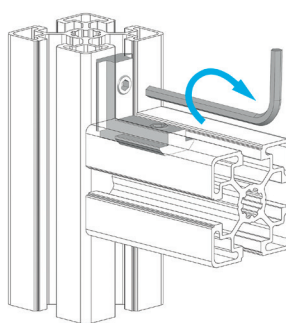

INNER BRACKET
GIUNTO INTERNO
ESCUADRA INTERNA
EQUERRE INTERNE
INNENVERBINDER

BH 105 45

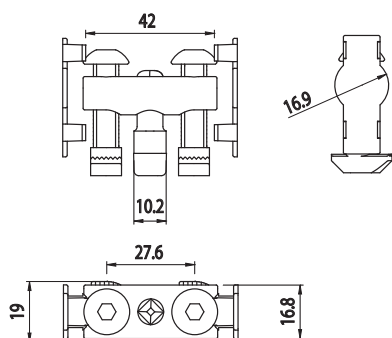
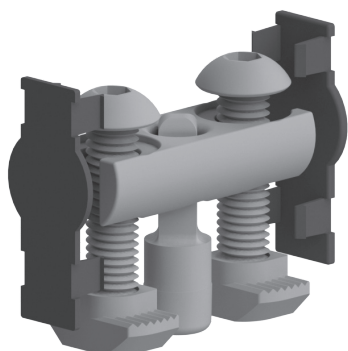

Cod	Note	g
084.307.031	Connector with through-pin - Connettore con perno passante - Conector con perno pasante - Connecteur avec pivot passant - Steckverbinder mit Durchsteckbolzen	75

Galvanised steel

Acciaio zincato
Acero galvanizado
Acier zingué
Verzinkter Stahl

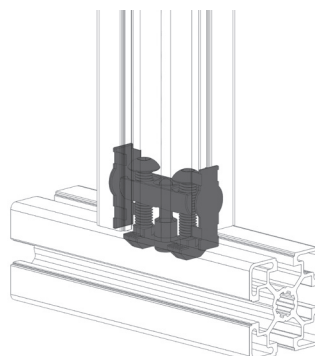



INNER BRACKET
GIUNTO INTERNO
ESCUADRA INTERNA
EQUERRE INTERNE
INNENVERBINDER

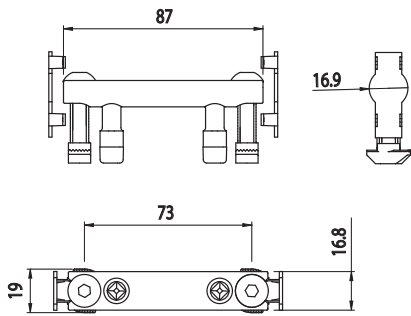
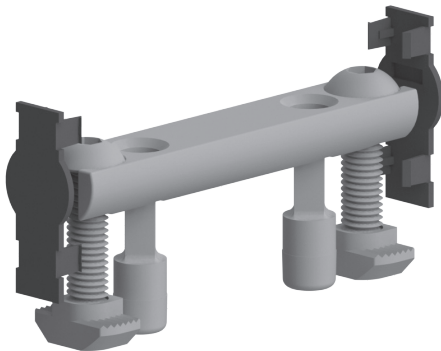

Cod	Note	g
084.307.032	Connector with through-pin - Connettore con perno passante - Conector con perno pasante - Connecteur avec pivot passant - Steckverbinder mit Durchsteckbolzen	130

Galvanised steel
Acciaio zincato
Acero galvanizado
Acier zingué
Verzinkter Stahl

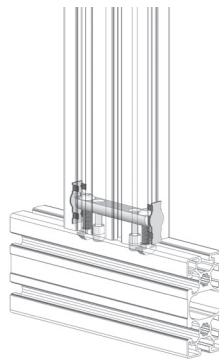

AUTOMATIC CONNECTOR
GIUNTO INTERNO
UNIÓN INTERNA
LIAISON SANS USINAGE
AUTOMATIKVERBINDER

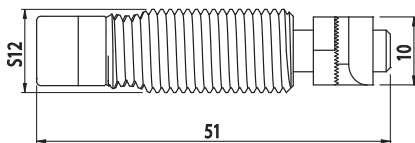
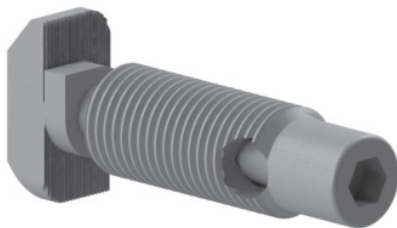

Cod	Note	g
084.312.014	Screw and nut included - Completo di vite e dado - Tornillo y tuerca incluidos - Vis et écrou fournis - Schraube und Mutter im Lieferumfang enthalten	13

Galvanised steel
Acciaio zincato
Acero galvanizado
Acier zingué
Verzinkter Stahl

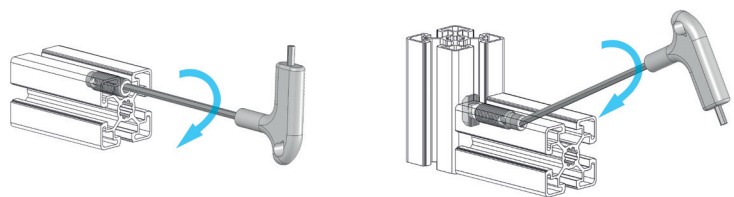

**CUBIC CONNECTOR 2D**

GIUNTO 2 VIE
CONECTOR CÚBICO 2D
RACCORD CUBE 2D
WÜRFELERBINDER 2D

BH
105
45

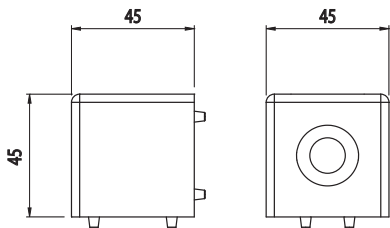
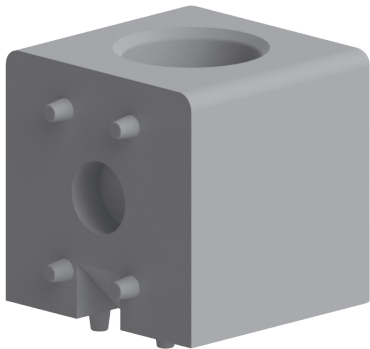

Cod	Note	g
084.310.020	Complete with plastic caps - Completo di tappi in plastica - Incluye tapones de plástico - Avec bouchons en plastique - Einschließlich Abdeckkappen aus Kunststoff	170

Galvanised steel

Acciaio zincato
Acero galvanizado
Acier zingué
Verzinkter Stahl

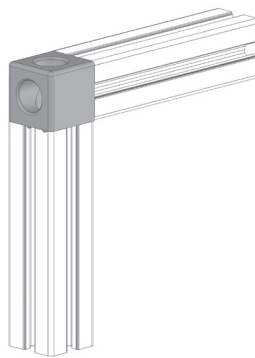
**CUBIC CONNECTOR 3D**

GIUNTO 3 VIE
CONECTOR CÚBICO 3D
RACCORD CUBE 3D
WÜRFELVERBINDER 3D

BH
105
45

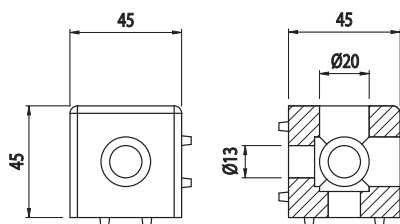
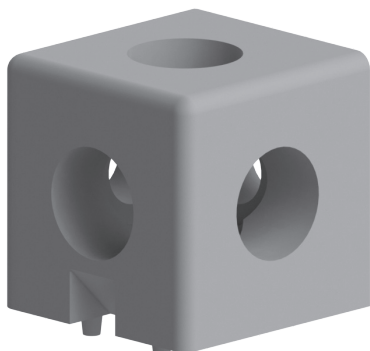

Cod	Note	g
084.310.021	Completo di tappi in plastica - Complete with plastic caps - Incluye tapones de plástico - Avec bouchons en plastique - Einschließlich Abdeckkappen aus Kunststoff	152

Galvanised steel

Acciaio zincato
Acero galvanizado
Acier zingué
Verzinkter Stahl

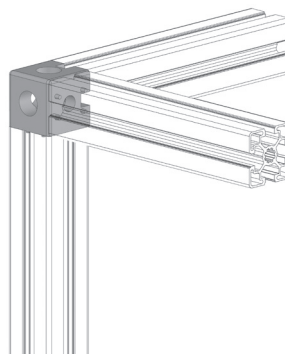



THREE-WAY CORNER BRACKET

GIUNTO 3 VIE
ESCUADRA 3 VÍAS
EQUERRE 3 VOIES
3-WEGE ECKWINKEL

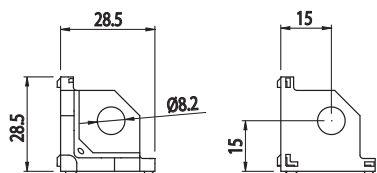
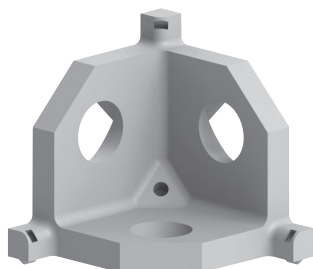

Cod	Note	g
084.310.022	Screws included - Completo di viti - Tornillos incluidos - Vis fournies - Schrauben im Lieferumfang enthalten	15

Sandblasted aluminium

Alluminio sabbato
Aluminio arenado
Aluminium sablé
Sandgestrahltes Aluminium

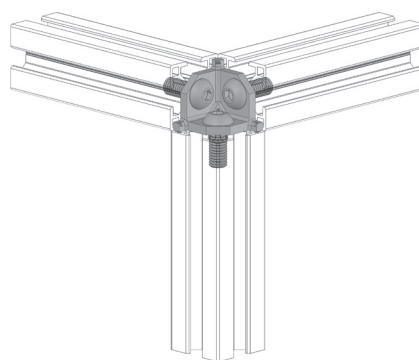

BRACKET COVER

TAPPO TONDO 3 VIE
TAPA PARA ESCUADRA
EMBOUT EQUERRE
ABDECKKAPPE FÜR ECKWINKEL

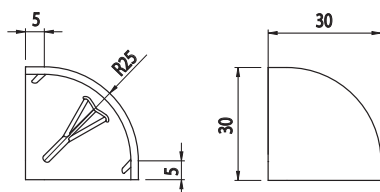

Cod	Note	Color	g
084.310.023	For 084.310.022 - Per 084.310.022 - Para 084.310.022 - Pour 084.310.022 - Für 084.310.022	■	6
084.310.023G	Pour 084.310.022 - Per 084.310.022 - Para 084.310.022 - Pour 084.310.022 - Für 084.310.022	■	6

Polyamide

Poliammide
Poliamida
Polyamide
Polyamid

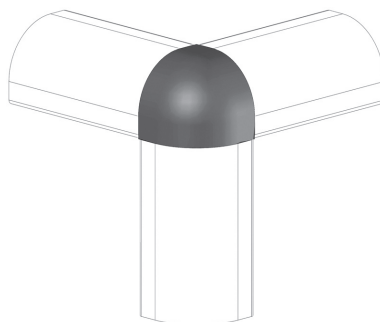

**BRACKET COVER**

TAPPO QUADRO 3 VIE
TAPA PARA ESCUADRA
EMBOUT EQUERRE
ABDECKKAPPE FÜR ECKWINKEL

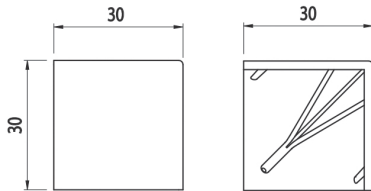
Cod	Note	Color	g
084.310.024	For 084.310.022 - Per 084.310.022 - Para 084.310.022 - Pour 084.310.022 - Für 084.310.022	■	6
084.310.024G	For 084.310.022 - Per 084.310.022 - Para 084.310.022 - Pour 084.310.022 - Für 084.310.022	■	6

Polyamide

Poliammide
Poliamida
Polyamide
Polyamid

**THREE-WAY CORNER BRACKET**

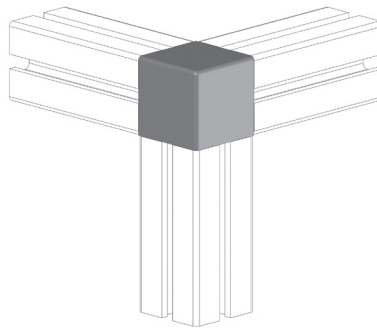
GIUNTO 3 VIE
ESCUADRA 3 VÍAS
EQUERRE 3 VOIES
3-WEGE ECKWINKEL

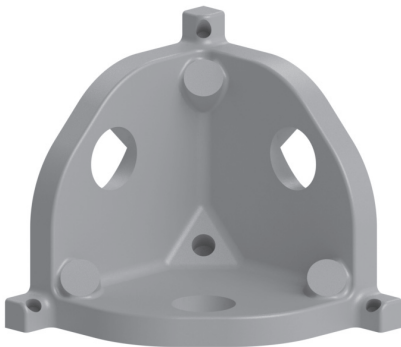
Cod	Note	g
084.310.027	Screws included - Completo di viti - Tornillos incluidos - Vis fournies - Schrauben im Lieferumfang enthalten	22,6

Sandblasted aluminium

Alluminio sabbiato
Aluminio arenado
Aluminium sablé
Sandgestrahltes Aluminium



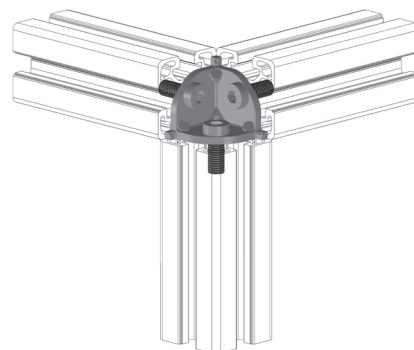
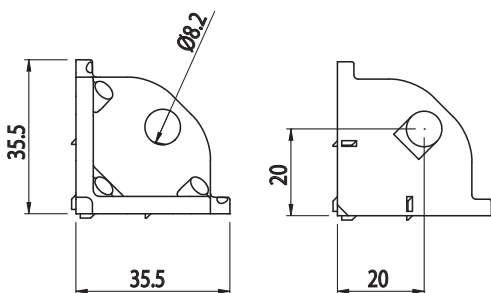

BRACKET COVER

TAPPO QUADRO 3 VIE
TAPA PARA ESCUADRA
EMBOU QUERRE
ABDECKKAPPE FÜR ECKWINKEL

BH
105
40

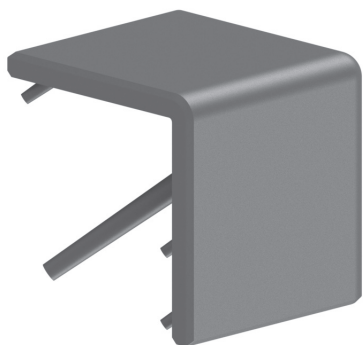

Cod	Note	Color	g
084.310.029	For 084.310.027 - Per 084.310.027 - Para 084.310.027 - Pour 084.310.027 - Für 084.310.022	■	10,8

Polyamide

Poliammide
Poliamida
Polyamide
Polyamid

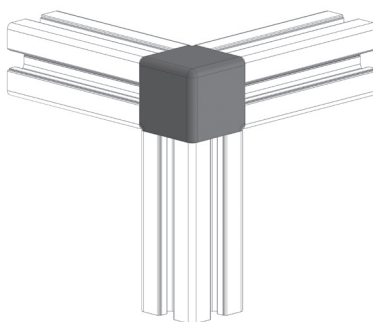
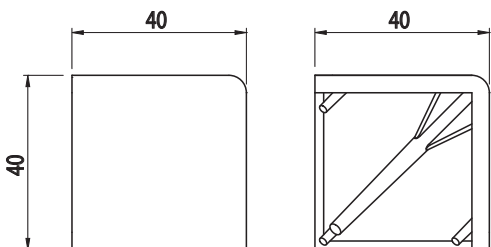

THREE-WAY CORNER BRACKET

GIUNTO 3 VIE
ESCUADRA 3 VÍAS
EQUERRE 3 VOIES
3-WEGE ECKWINKEL

BH
105
45

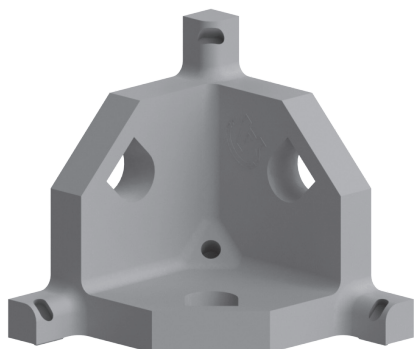

Cod	Note	g
084.310.013	Screws included - Completo di viti - Tornillos incluidos - Vis fournies - Schrauben im Lieferumfang enthalten	114

Zamak

Zama
Zamak
Zamak
Zamak

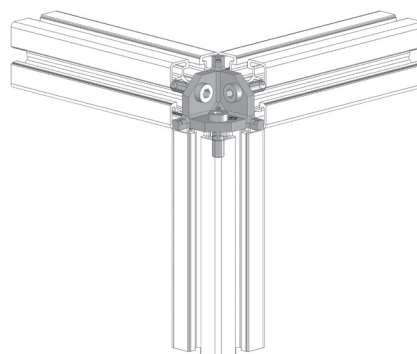
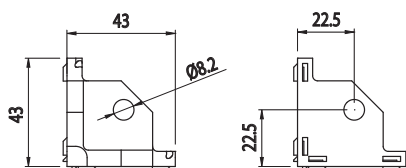

**BRACKET COVER**

TAPPO TONDO 3 VIE
TAPA PARA ESCUADRA
EMBOUÉ EQUERRE
ABDECKKAPPE FÜR ECKWINKEL

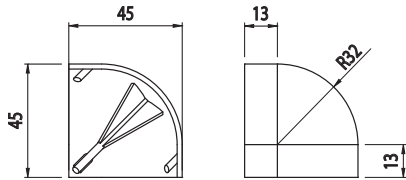
Cod	Note	Color	g
084.310.014	For 084.310.013 - Per 084.310.013 - Para 084.310.013 - Pour 084.310.013 - Für 084.310.013	■	9
084.310.014G	For 084.310.013 - Per 084.310.013 - Para 084.310.013 - Pour 084.310.013 - Für 084.310.013	■	9

Polyamide

Poliammide
Poliamida
Polyamide
Polyamid

**BRACKET COVER**

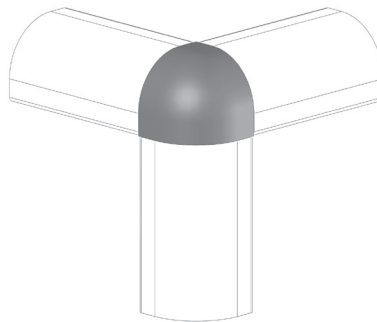
TAPPO QUADRO 3 VIE
TAPA PARA ESCUADRA
EMBOUÉ EQUERRE
ABDECKKAPPE FÜR ECKWINKEL

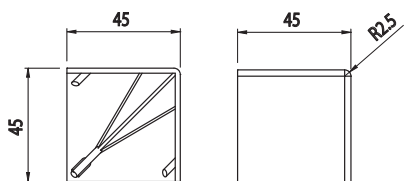
Cod	Note	Color	g
084.310.015	For 084.310.013 - Per 084.310.013 - Para 084.310.013 - Pour 084.310.013 - Für 084.310.013	■	14
084.310.015G	For 084.310.013 - Per 084.310.013 - Para 084.310.013 - Pour 084.310.013 - Für 084.310.013	■	14

Polyamide

Poliammide
Poliamida
Polyamide
Polyamid



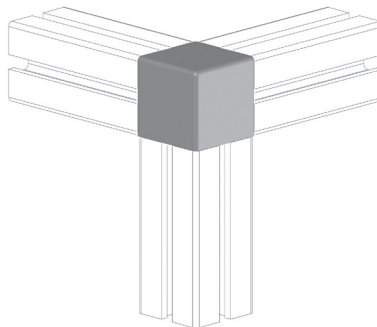

SWIVEL JOINT, 40X40
 GIUNTO SNODATO 40X40
 ARTICULACIÓN GRADUABLE 40x40
 ARTICULATION 40x40
 GELENK 40x40

BH
105
40

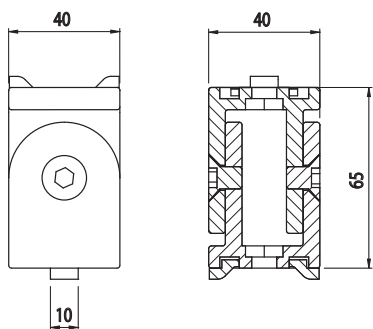
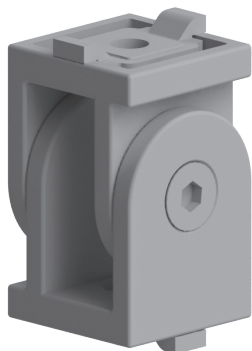

Cod	Note	g
084.311.021	With orientable anti-rotation system. - Con sistema antirotazione orientabile. - Con sistema antirrotación orientable. - Avec système anti-rotation orientable. - Mit verstellbarer Verdrehsicherung.	146

Sandblasted aluminium
 Alluminio sabbato
 Aluminio arenado
 Aluminium sablé
 Sandgestrahltes Aluminium

Use 084.312.003 bushings
 Usare boccole 084.312.003
 Usar casquillos 084.312.003
 Utiliser bagues 084.312.003
 Buchsen 084.312.003 verwenden

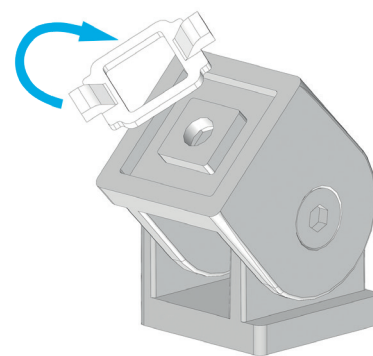
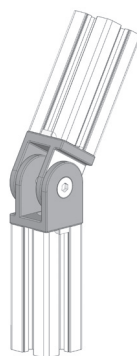

SWIVEL JOINT, 45X45
 GIUNTO SNODATO 45X45
 ARTICULACIÓN GRADUABLE 45x45
 ARTICULATION 45x45
 GELENK 45x45

BH
105
40

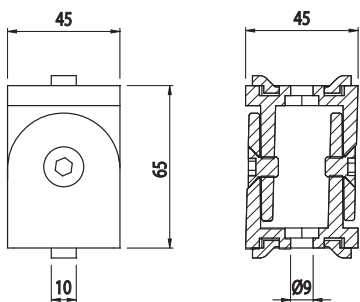
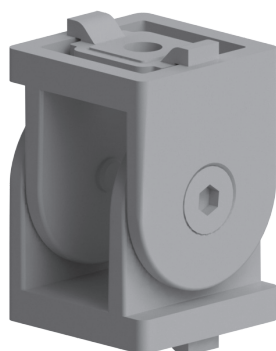

Cod	Note	g
084.311.016	With orientable anti-rotation system. - Con sistema antirotazione orientabile. - Con sistema antirrotación orientable. - Avec système anti-rotation orientable. - Mit verstellbarer Verdrehsicherung.	210

Sandblasted aluminium
 Alluminio sabbato
 Aluminio arenado
 Aluminium sablé
 Sandgestrahltes Aluminium

Use 084.312.003 bushings
 Usare boccole 084.312.003
 Usar casquillos 084.312.003
 Utiliser bagues 084.312.003
 Buchsen 084.312.003 verwenden

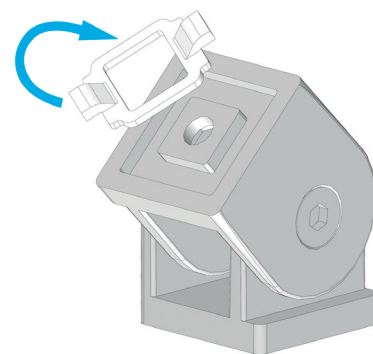
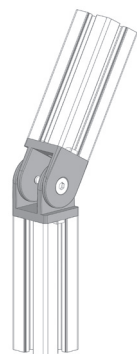

**SWIVEL JOINT, 45X45, ADJUSTABLE**

GIUNTO SNODATO 45X45 FRIZIONABILE
ARTICULACIÓN GRADUABLE 45x45 AJUSTABLE
ARTICULATION 45x45 RÉGLABLE
GELENK 45x45, EINSTELLBAR

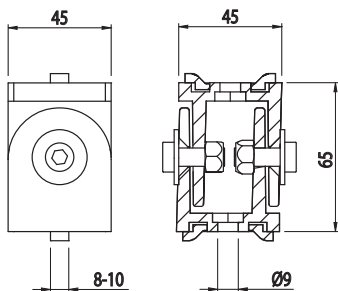
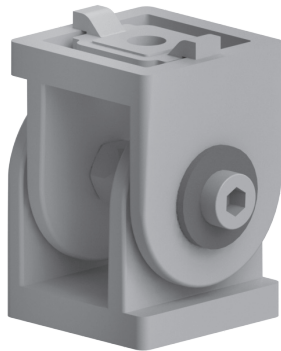
Cod	Note	g
084.311.020	With orientable anti-rotation system - Con sistema antirotazione orientabile - Con sistema antirrotación orientable - Avec système anti-rotation orientable - Mit verstellbarer Verdrehsicherung	230

Sandblasted aluminium

Alluminio sabbiato
Aluminio arenado
Aluminium sablé
Sandgestrahltes Aluminium

Use 084.312.003 bushings

Usare boccole 084.312.003
Usar casquillos 084.312.003
Utiliser bagues 084.312.003
Buchsen 084.312.003 verwenden

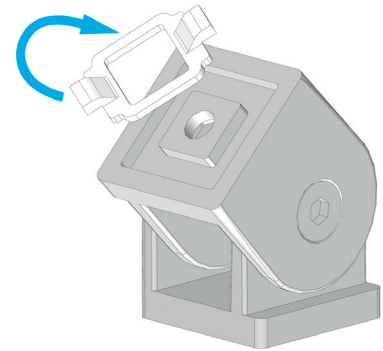
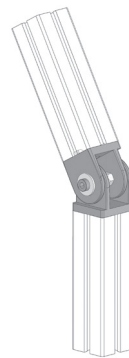
**SWIVEL JOINT, 45X45, WITH LOCKING LEVER**

GIUNTO SNODATO 45X45 A LEVA
ARTICULACIÓN GRADUABLE 45x45 CON PALANCA
ARTICULATION 45x45 AVEC BLOCAJE
GELENK 45x45 MIT KLEMMHEBEL

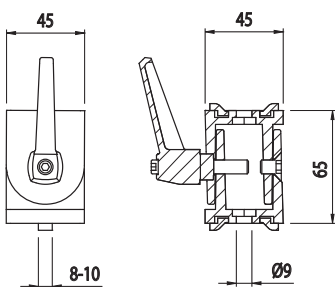
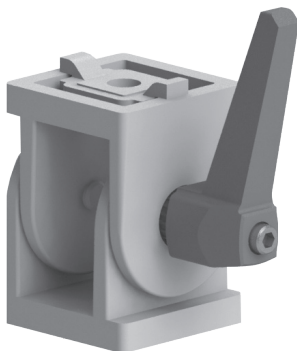
Cod	Note	g
084.311.019	With orientable anti-rotation system - Con sistema antirotazione orientabile - Con sistema antirrotación orientable - Avec système anti-rotation orientable - Mit verstellbarer Verdrehsicherung	240

Sandblasted aluminium

Alluminio sabbiato
Aluminio arenado
Aluminium sablé
Sandgestrahltes Aluminium

Use 084.312.003 bushings

Usare boccole 084.312.003
Usar casquillos 084.312.003
Utiliser bagues 084.312.003
Buchsen 084.312.003 verwenden

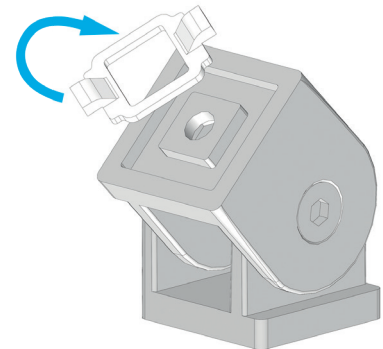
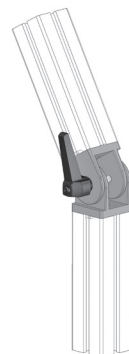



SWIVEL JOINT, 40X80
GIUNTO SNODATO 40X80
ARTICULACIÓN GRADUABLE 40x80
ARTICULATION 40x80
GELENK 40x80

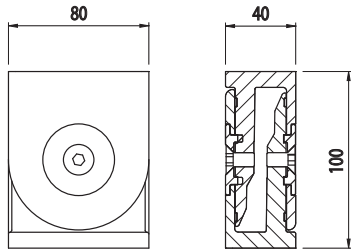
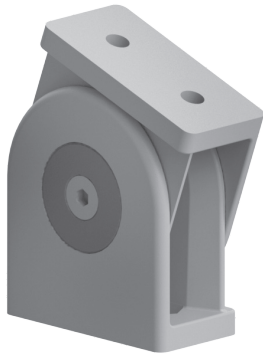

Cod	Note	g
084.311.011	With anti-rotation system - Con sistema antirotazione - Con sistema antirrotación - Avec système anti-rotation - Mit Verdrehsicherung	997

Zamak
Zama
Zamak
Zamak
Zamak

Use 084.312.003 bushings
Usare boccole 084.312.003
Usar casquillos 084.312.003
Utiliser bagues 084.312.003
Buchsen 084.312.003 verwenden

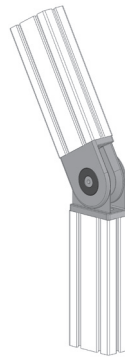

SWIVEL JOINT, 45X90
GIUNTO SNODATO 45X90
ARTICULACIÓN GRADUABLE 45x90
ARTICULATION 45x90
GELENK 45x90

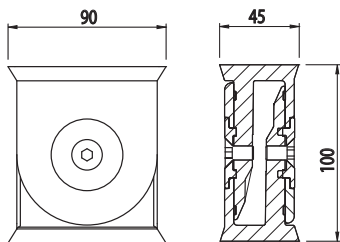
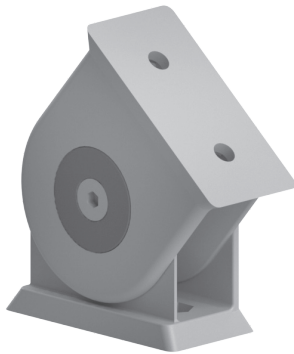

Cod	Note	g
084.311.012	With anti-rotation system - Con sistema antirotazione - Con sistema antirrotación - Avec système anti-rotation - Mit Verdrehsicherung	1120

Aluminium
Alluminio
Aluminio
Aluminium
Aluminium

Use 084.312.003 bushings
Usare boccole 084.312.003
Usar casquillos 084.312.003
Utiliser bagues 084.312.003
Buchsen 084.312.003 verwenden

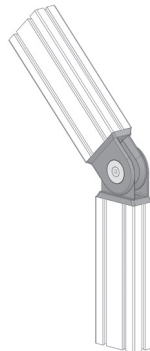

**CONNECTION PLATE 40X40**

PIASTRA DI FISSAGGIO 40X40
 PLETINA DE UNIÓN 40x40
 PLATINE D'ASSEMBLAGE 40x40
 BEFESTIGUNGSPLATTE 40x40

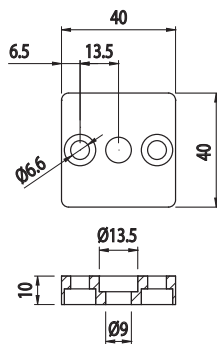
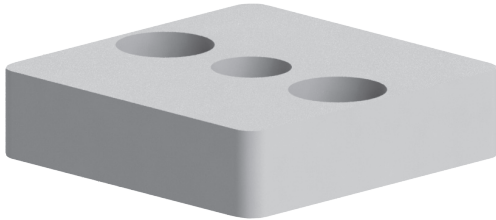

Cod	Note	g
084.308.003	For 40x40 profile - Per profilo 40x40 - Para perfil 40x40 - Pour profilé 40x40 - Für Profil 40x40	40

**Anodised aluminium**

Alluminio anodizzato
 Aluminio anodizado
 Aluminium anodisé
 Eloxiertes Aluminium

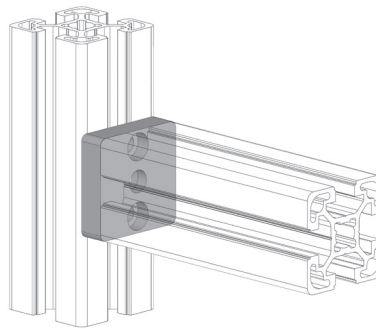
**CONNECTION PLATE 45X45**

PIASTRA DI FISSAGGIO 45X45
 PLETINA DE UNIÓN 45x45
 PLATINE D'ASSEMBLAGE 45x45
 BEFESTIGUNGSPLATTE 45x45

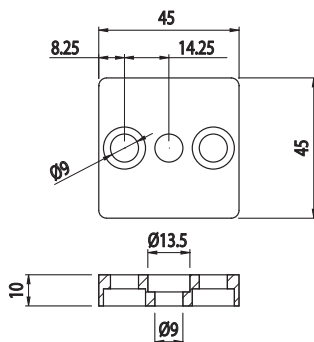
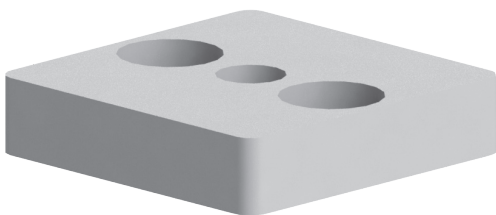

Cod	Note	g
084.308.001	For 45x45 profile - Per profilo 45x45 - Para perfil 45x45 - Pour profilé 45x45 - Für Profil 45x45	45

**Anodised aluminium**

Alluminio anodizzato
 Aluminio anodizado
 Aluminium anodisé
 Eloxiertes Aluminium

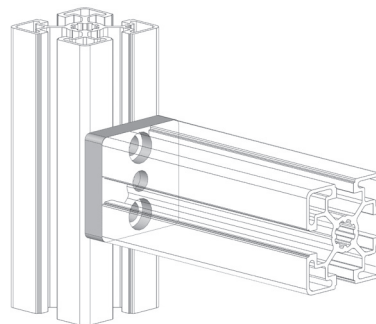



CONNECTION PLATE 40X80

PIASTRA DI FISSAGGIO 40X80
PLETINA DE UNIÓN 40x80
PLATINE D'ASSEMBLAGE 40x80
BEFESTIGUNGSPLATTE 40x80



Cod	Note	g
084.308.004	For 40x80 profile - Per profilo 40x80 - Para perfil 40x80 - Pour profilé 40x80 - Für Profil 40x80	80

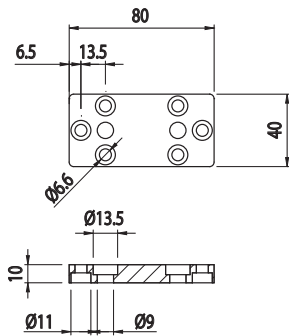
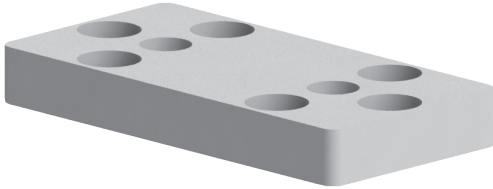

Anodised aluminium

Alluminio anodizzato
Aluminio anodizado
Aluminium anodisé
Eloxiertes Aluminium

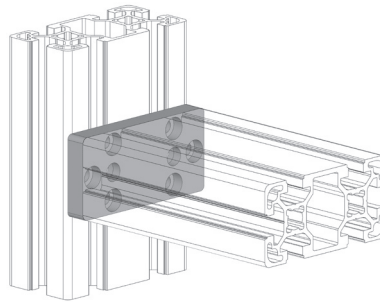

CONNECTION PLATE 45X90

PIASTRA DI FISSAGGIO 45X90
PLETINA DE UNIÓN 45x90
PLATINE D'ASSEMBLAGE 45x90
BEFESTIGUNGSPLATTE 45x90



Cod	Note	g
084.308.002	For 45x90 profile - Per profilo 45x90 - Para perfil 45x90 - Pour profilé 45x90 - Für Profil 45x90	85

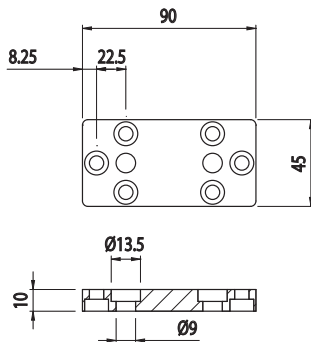
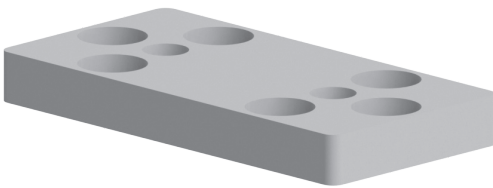

Anodised aluminium

Alluminio anodizzato
Aluminio anodizado
Aluminium anodisé
Eloxiertes Aluminium

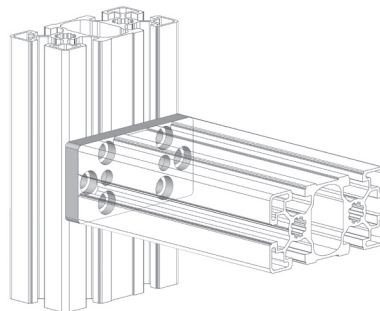

**CONNECTION PLATE 50X50**

PIASTRA DI FISSAGGIO 50X50
 PLETINA DE UNIÓN 50x50
 PLETINE D'ASSEMBLAGE 50x50
 BEFESTIGUNGSPLATTE 50x50

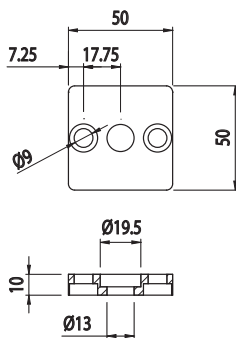
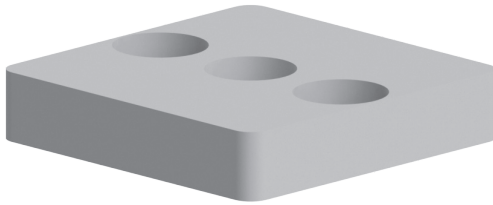

Cod	Note	g
084.308.006	For 50x50 profile - Per profilo 50x50 - Para perfil 50x100 - Pour profilé 50x50 - Für profil 50x50	60

Anodised aluminium

Alluminio anodizzato
 Aluminio anodizado
 Aluminium anodisé
 Eloxiertes Aluminium

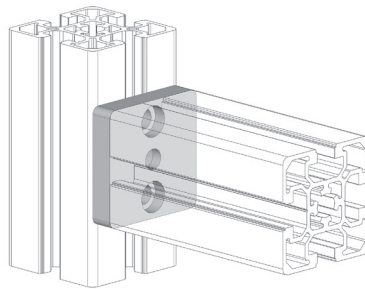
**CONNECTION PLATE 50X100**

PIASTRA DI FISSAGGIO 50X100
 PLETINA DE UNIÓN 50x100
 PLETINE D'ASSEMBLAGE 50x100
 BEFESTIGUNGSPLATTE 50x100

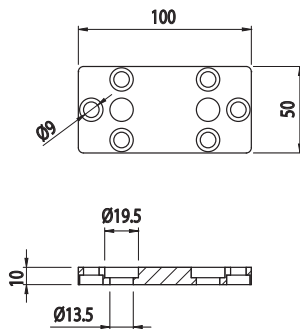
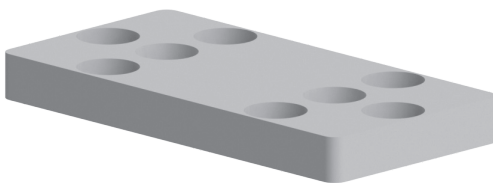
Cod	Note	g
084.308.007	For 50x100 profile - Per profilo 50x100 - Para perfil 50x100 - Pour profilé 50x100 - Für Profil 50x100	110

Anodised aluminium

Alluminio anodizzato
 Aluminio anodizado
 Aluminium anodisé
 Eloxiertes Aluminium



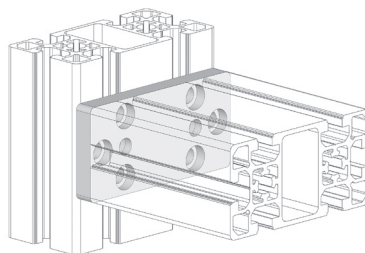

45° ANGLE CONNECTOR

CONNETTORE 45°
UNIÓN 45°
ELÉMENT DE JONCTION 45°
WINKELVERBINDER 45°

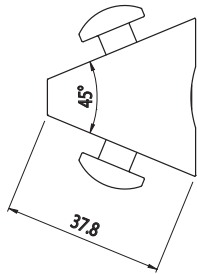

Cod	Note	g
084.307.030	45° connection without machining - Connessione a 45° senza lavorazioni - Unión en 45° sin mecanizados - Connexion à 45° sans usinage - 45°-Anschluss ohne Bearbeitungen	65

Anodised aluminium

Alluminio anodizzato
Aluminio anodizado
Aluminium anodisé
Eloxiertes Aluminium

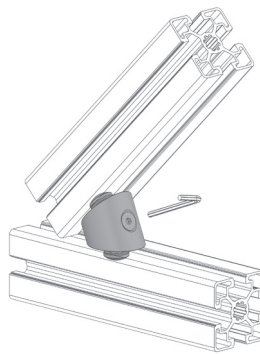

45° ANGLE CONNECTOR

CONNETTORE 45°
UNIÓN 45°
ELÉMENT DE JONCTION 45°
WINKELVERBINDER 45°

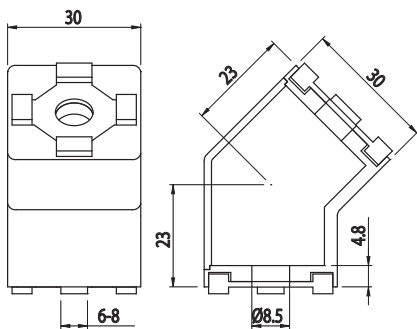
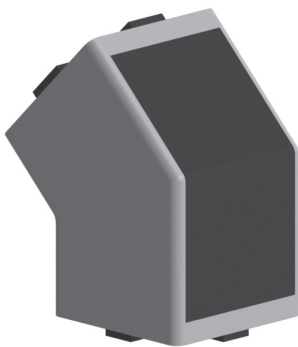

Cod	Note	g
084.305.050	For 30x30 profiles - Per profili 30x30 - Para perfiles 30x30 - Pour profilés 30x30 - Für 30x30 Profile	50

Zamak

Zama
Zamak
Zamak
Zamak

Black polyamide

Poliammide nero
Poliamida color negro
Polyamide noir
Polyamid schwarz

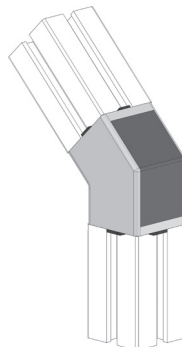

**45° ANGLE CONNECTOR**

GIUNTO 45°
UNIÓN 45°
ELÉMENT DE JONCTION 45°
WINKELVERBINDER 45°

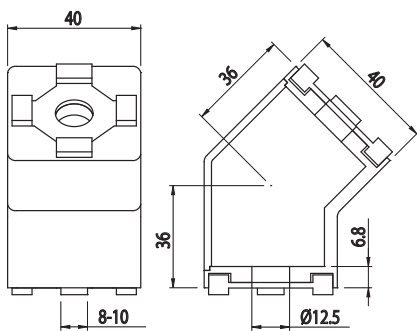
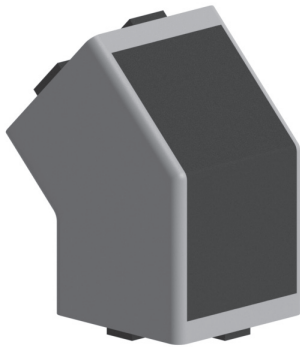
Cod	Note	g
084.305.051	For 40x40 profiles - Per profili 40x40 - Para perfiles 40x40 - Pour profilés 40x40 - Für 40x40 Profile	125

Zamak

Zama
Zamak
Zamak
Zamak

Black polyamide

Poliammide nero
Poliamida color negro
Polyamide noir
Polyamid schwarz

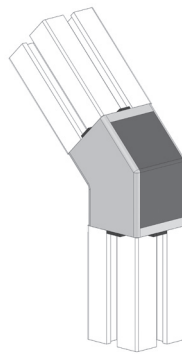
**45° ANGLE CONNECTOR**

GIUNTO 45°
UNIÓN 45°
ELÉMENT DE JONCTION 45°
WINKELVERBINDER 45°

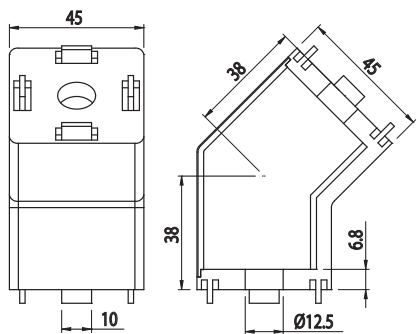
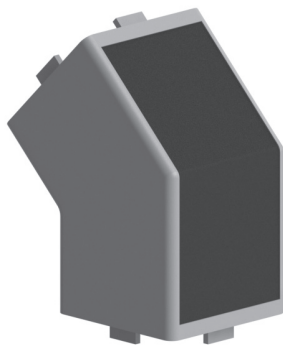
Cod	Note	g
084.305.052	Per profili 45x45 - For 45x45 profiles - Para perfiles 45x45 - Pour profilés 45x45 - Für 45x45 Profile	154

Zamak

Zama
Zamak
Zamak
Zamak

Black polyamide

Poliammide nero
Poliamida color negro
Polyamide noir
Polyamid schwarz

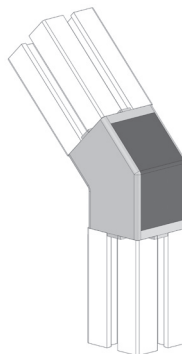



13X22 BRACKET

ANGOLARE 13X22
 ESCUADRA 13X22
 EQUERRE 13X22
 ALUWINKEL 13X22

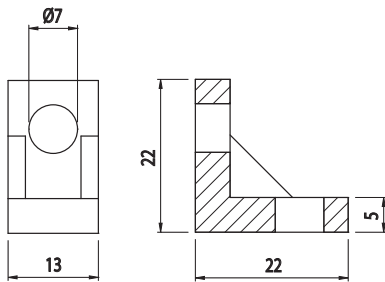
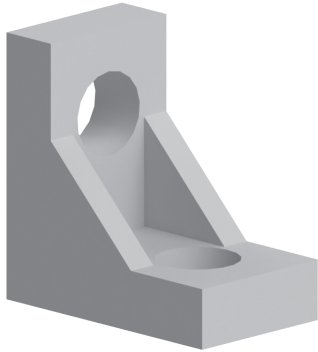

Cod	Note	g
084.305.006	Assembly with M6x12 screws, not included - Montaggio con viti M6x12 non incluse - Montaje con tornillos M6x12, no incluidos - Montage avec vis M6x12 non fournies - Montage mit Schrauben M6x12 (nicht im Lieferumfang enthalten)	6

Sandblasted aluminium

Alluminio sabbiato
 Aluminio arenado
 Aluminium sablé
 Sandgestrahltes Aluminium

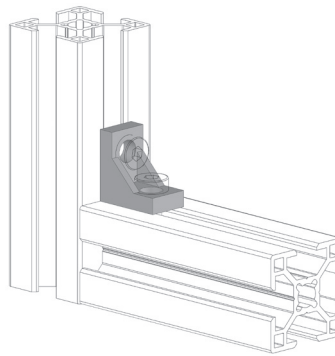

18X18 BRACKET

ANGOLARE 18X18
 ESCUADRA 18X18
 EQUERRE 18X18
 ALUWINKEL 18X18

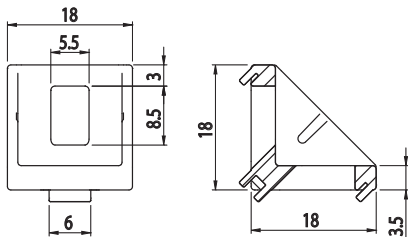
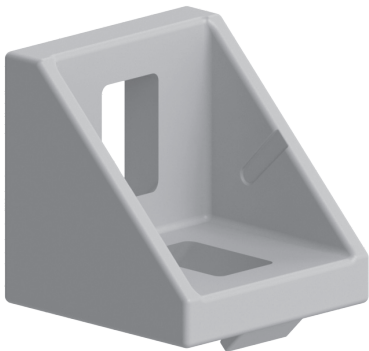

Cod	Note	g
084.305.032	Assembly with M5x12 screws, not included - Montaggio con viti M5x12 non incluse - Montaje con tornillos M5x12, no incluidos - Montage avec vis M5x12 non fournies - Montage mit Schrauben M5x12 (nicht im Lieferumfang enthalten)	5

Sandblasted aluminium

Alluminio sabbiato
 Aluminio arenado
 Aluminium sablé
 Sandgestrahltes Aluminium

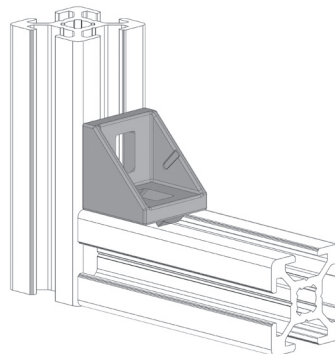

Cap - Tappo - Tapón - Embout - Abdeckkappe			
Cod	Mat	g	Col
084.206.007	PA	3	■
084.206.007G	PA	3	■



27X27 BRACKET
 ANGOLARE 27X27
 ESCUADRA 27X27
 EQUERRE 27X27
 ALUWINKEL 27X27

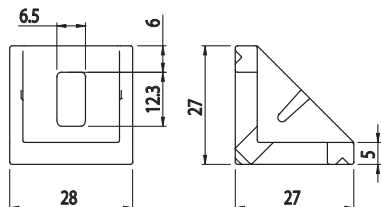
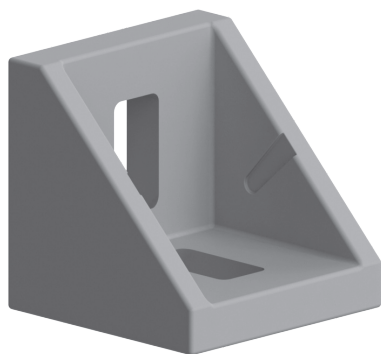

Cod	Note	g
084.305.010	Assembly with M6x16 screws, not included - Montaggio con viti M6x16 non incluse - Montaje con tornillos M6x16, no incluidos - Montage avec vis M6x16 non fournies - Montage mit Schrauben M6x16 (nicht im Lieferumfang enthalten)	29

Sandblasted aluminium

Alluminio sabbiato
 Aluminio arenado
 Aluminium sablé
 Sandgestrahltes Aluminium

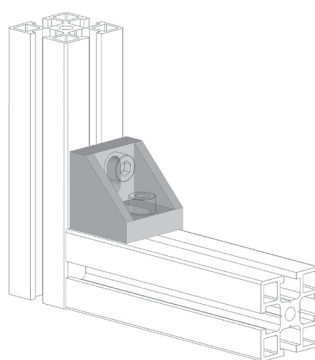

Cap - Tappo - Tapòn - Embout - Abdeckkappe			
Cod	Mat	g	Col
084.206.008	PA	6	■
084.206.008G	PA	6	■

27X27 BRACKET
 ANGOLARE 27X27
 ESCUADRA 27X27
 EQUERRE 27X27
 ALUWINKEL 27X27

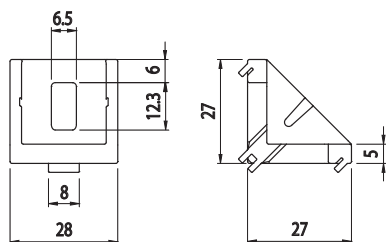
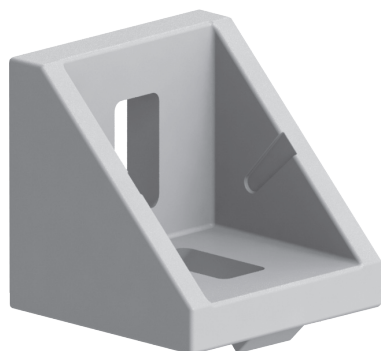

Cod	Note	g
084.305.036	Assembly with M6x16 screws, not included - Montaggio con viti M6x16 non incluse - Montaje con tornillos M6x16, no incluidos - Montage avec vis M6x16 non fournies - Montage mit Schrauben M6x16 (nicht im Lieferumfang enthalten)	19

Sandblasted aluminium

Alluminio sabbiato
 Aluminio arenado
 Aluminium sablé
 Sandgestrahltes Aluminium

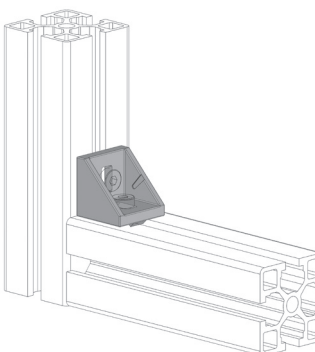

Cap - Tappo - Tapòn - Embout - Abdeckkappe			
Cod	Mat	g	Col
084.206.008	PA	6	■
084.206.008G	PA	6	■



27X59 BRACKET

ANGOLARE 27X59
ESCUADRA 27X59
EQUERRE 27X59
ALUWINKEL 27X59

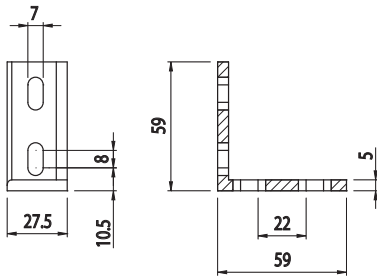
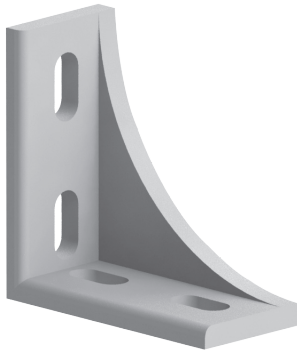

Cod	Note	g
084.305.007	Assembly with M6x16 screws, not included - Montaggio con viti M6x16 non incluse - Montaje con tornillos M6x16, no incluidos - Montage avec vis M6x16 non fournies - Montage mit Schrauben M6x16 (nicht im Lieferumfang enthalten)	46

Sandblasted aluminium

Alluminio sabbato
Aluminio arenado
Aluminium sablé
Sandgestrahltes Aluminium

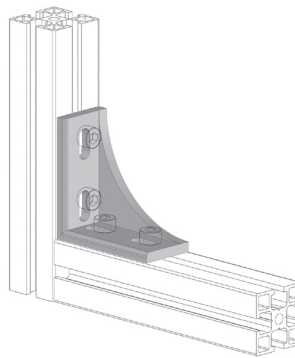

59X59 BRACKET

ANGOLARE 59X59
ESCUADRA 59X59
EQUERRE 59X59
ALUWINKEL 59X59

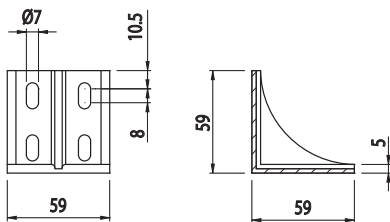
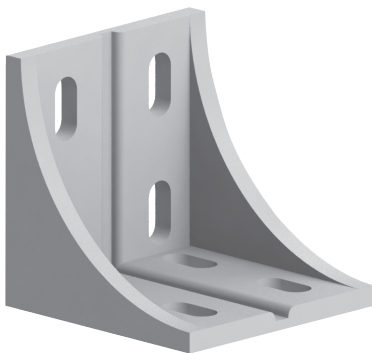

Cod	Note	g
084.305.008	Assembly with M6x16 screws, not included - Montaggio con viti M6x16 non incluse - Montaje con tornillos M6x16, no incluidos - Montage avec vis M6x16 non fournies - Montage mit Schrauben M6x16 (nicht im Lieferumfang enthalten)	93

Sandblasted aluminium

Alluminio sabbato
Aluminio arenado
Aluminium sablé
Sandgestrahltes Aluminium

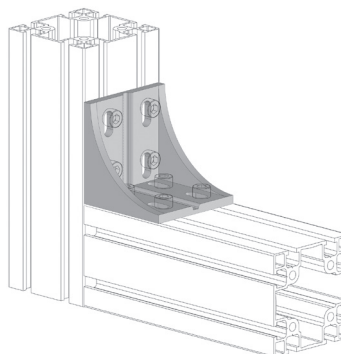

**18X40 BRACKET**

ANGOLARE 18X40
ESCUADRA 18X40
EQUERRE 18X40
ALUWINKEL 18X40

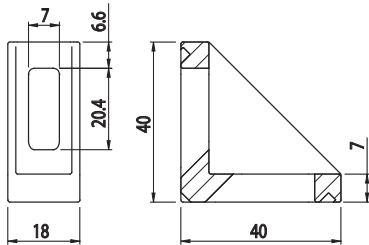
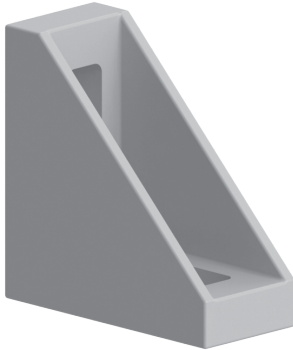

Cod	Note	g
084.305.001	Assembly with M6 screws, not included - Montaggio con viti M6 non incluse - Montaje con tornillos M6, no incluidos - Montage avec vis M6 non fournies - Montage mit Schrauben M6 (nicht im Lieferumfang enthalten)	20

Sandblasted aluminium

Alluminio sabbiato
Aluminio arenado
Aluminium sablé
Sandgestrahltes Aluminium

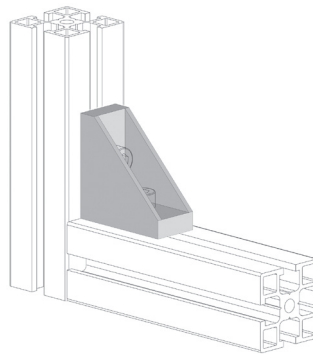

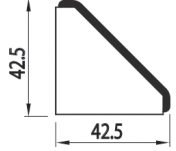
Cap - Tappo - Tapòn - Embout - Abdeckkappe			
		42.5	42.5
Cod	Mat	g	Col
084.206.001	PA	3	■
084.206.001G	PA	3	■

18X40 BRACKET

ANGOLARE 18X40
ESCUADRA 18X40
EQUERRE 18X40
ALUWINKEL 18X40

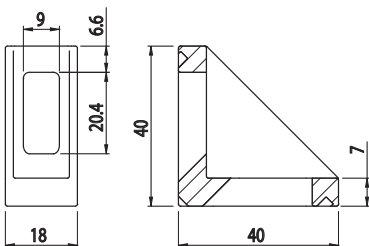

Cod	Note	g
084.305.041	Assembly with M8x20 screws, not included - Montaggio con viti M8x20 non incluse - Montaje con tornillos M8x20, no incluidos - Montage avec vis M8x20 non fournies - Montage mit Schrauben M8x20 (nicht im Lieferumfang enthalten)	20

Sandblasted aluminium

Alluminio sabbiato
Aluminio arenado
Aluminium sablé
Sandgestrahltes Aluminium

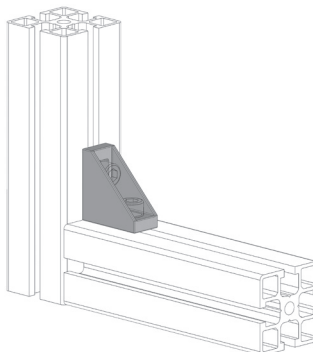

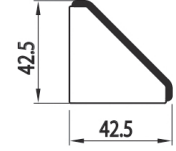
Cap - Tappo - Tapòn - Embout - Abdeckkappe			
		42.5	42.5
Cod	Mat	g	Col
084.206.001	PA	3	■
084.206.001G	PA	3	■



25X40 BRACKET

ANGOLARE 25X40
ESCUADRA 25X40
EQUERRE 25X40
ALUWINKEL 25X40

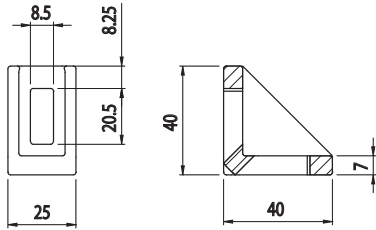

Cod	Note	g
084.305.002	Assembly with M8x20 screws, not included - Montaggio con viti M8x20 non incluse - Montaje con tornillos M8x20, no incluidos - Montage avec vis M8x20 non fournies - Montage mit Schrauben M8x20 (nicht im Lieferumfang enthalten)	30

Sandblasted aluminium

Alluminio sabbiato
Aluminio arenado
Aluminium sablé
Sandgestrahltes Aluminium

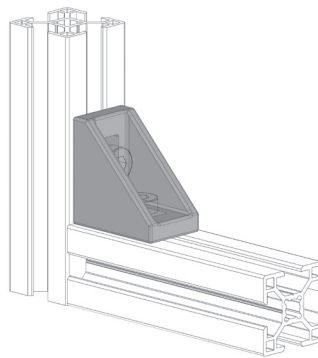

Cap - Tappo - Tapòn - Embout - Abdeckkappe			
Cod	Mat	g	Col
084.206.002	PA	4	■
084.206.002G	PA	4	■

25X40 BRACKET

ANGOLARE 25X40
ESCUADRA 25X40
EQUERRE 25X40
ALUWINKEL 25X40



NEW

Cod	Note	g
084.305.059	Assembly with M8x20 screws, not included - Montaggio con viti M8x20 non incluse - Montaje con tornillos M8x20, no incluidos - Montage avec vis M8x20 non fournies - Montage mit Schrauben M8x20 (nicht im Lieferumfang enthalten)	17

PA6+GF

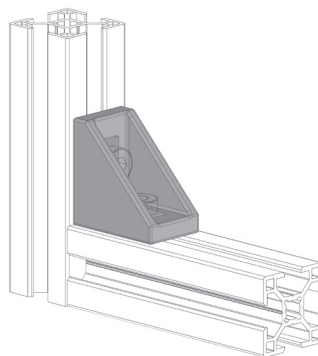
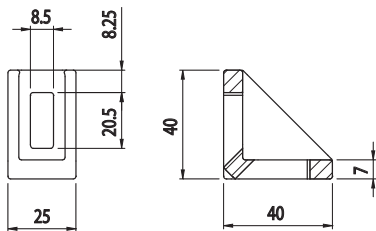

Cap - Tappo - Tapòn - Embout - Abdeckkappe			
Cod	Mat	g	Col
084.206.002	PA	4	■
084.206.002G	PA	4	■



25X40 BRACKET

ANGOLARE 25X40
 ESCUADRA 25X80
 EQUERRE 25X80
 ALUWINKEL 25X80

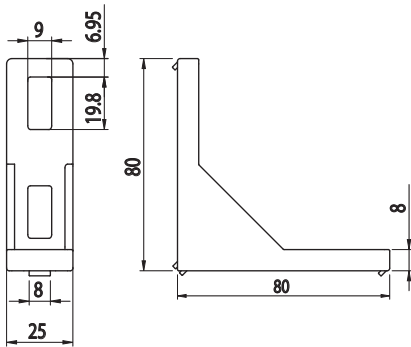

Cod	Note	g
084.305.044	Assembly with M8x20 screws, not included - Montaggio con viti M8x20 non incluse - Montaje con tornillos M8x20, no incluidos - Montage avec vis M8x20 non fournies - Montage mit Schrauben M8x20 (nicht im Lieferumfang enthalten)	63

Sandblasted aluminium

Alluminio sabbiato
 Aluminio arenado
 Aluminium sablé
 Sandgestrahltes Aluminium

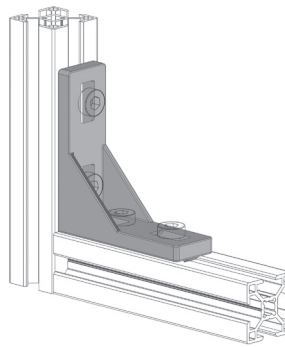

25X80 BRACKET

ANGOLARE 25X80
 ESCUADRA 25X80
 EQUERRE 25X80
 ALUWINKEL 25X80



NEW

Cod	Note	g
084.305.060	Assembly with M8x20 screws, not included - Montaggio con viti M8x20 non incluse - Montaje con tornillos M8x20, no incluidos - Montage avec vis M8x20 non fournies - Montage mit Schrauben M8x20 (nicht im Lieferumfang enthalten)	31

PA6+GF

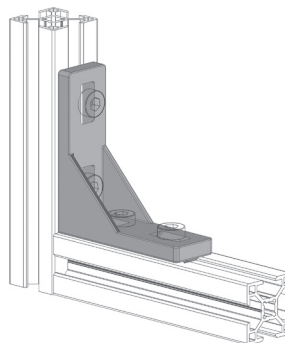
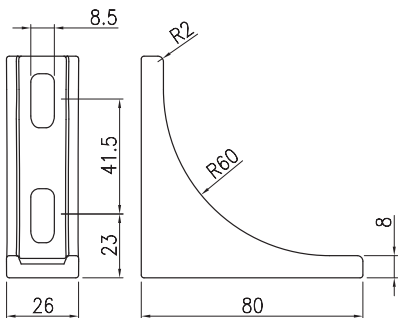



38X38 BRACKET

ANGOLARE 38X38
ESCUADRA 38X38
EQUERRE 38X38
ALUWINKEL 38X38

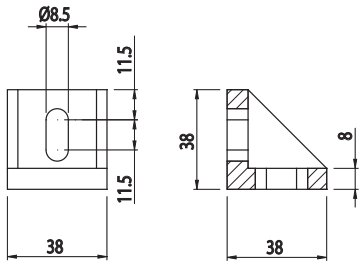
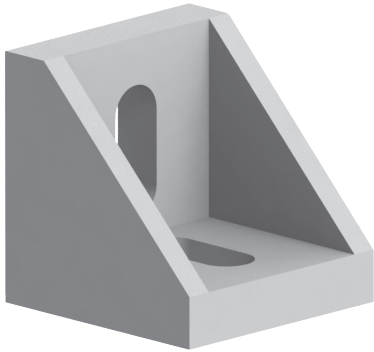

Cod	Note	g
084.305.009	Assembly with M8x20 screws, not included - Montaggio con viti M8x20 non incluse - Montaje con tornillos M8x20, no incluidos - Montage avec vis M8x20 non fournies - Montage mit Schrauben M8x20 (nicht im Lieferumfang enthalten)	50

Sandblasted aluminium

Alluminio sabbiato
Aluminio arenado
Aluminium sablé
Sandgestrahltes Aluminium

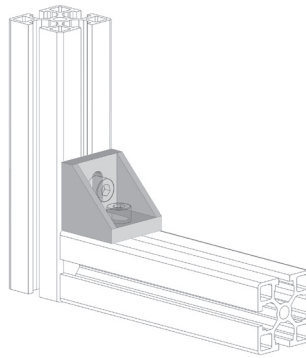

38X38 BRACKET

ANGOLARE 38X38
ESCUADRA 38X38
EQUERRE 38X38
ALUWINKEL 38X38

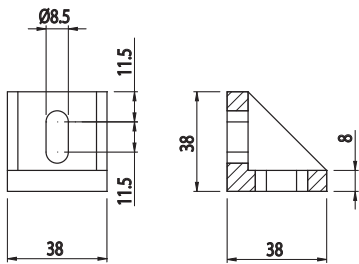
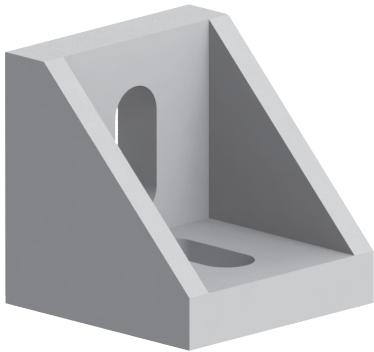

Cod	Note	g
084.305.009T	Assembly with M8x20 screws, not included - Montaggio con viti M8x20 non incluse - Montaje con tornillos M8x20, no incluidos - Montage avec vis M8x20 non fournies - Montage mit Schrauben M8x20 (nicht im Lieferumfang enthalten)	50

Tumbled zamak

Zama burattato
Zamak vibroacabado
Zamak tribofini
Gleitgeschliffene Zamak-Legierung

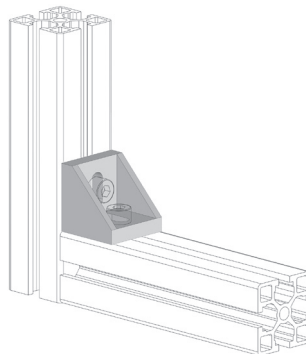

**30X30 BRACKET**

ANGOLARE 30X30
 ESCUADRA 30X30
 EQUERRE 30X30
 ALUWINKEL 30X30

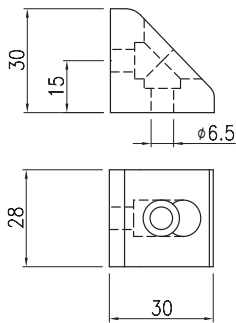
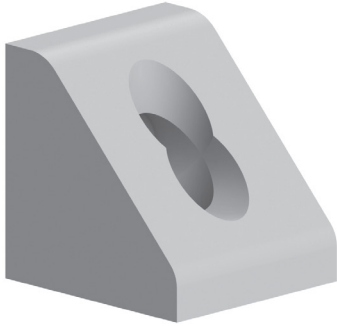
**NEW**

Cod	Note	g
084.305.058	Assembly with M6X16 screws, not included - Montaggio con viti M6X16 non incluse - Montaje con tornillos M6X16, no incluidos - Montage avec vis M6X16 non fournies - Montage mit Schrauben M6X16 (nicht im Lieferumfang enthalten)	41

Tumbled aluminium

Alluminio burattato
 Aluminio vibroacabado
 Aluminium tribofini
 Gleitgeschliffene Aluminium

40X40 BRACKET

ANGOLARE 40X40
 ESCUADRA 40X40
 EQUERRE 40X40
 ALUWINKEL 40X40

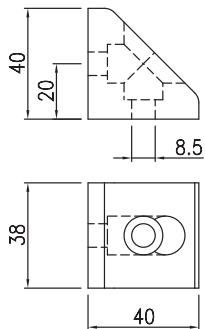
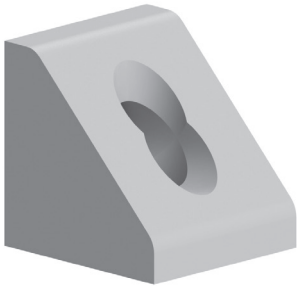

Cod	Note	g
084.305.054	Assembly with M8x20 screws, not included - Montaggio con viti M8x20 non incluse - Montaje con tornillos M8x20, no incluidos - Montage avec vis M8x20 non fournies - Montage mit Schrauben M8x20 (nicht im Lieferumfang enthalten)	99

Sandblasted aluminium

Alluminio sabbiato
 Aluminio arenado
 Aluminium sablé
 Sandgestrahltes Aluminium



36X36 BRACKET

ANGOLARE 36X36
 ESCUADRA 36X36
 EQUERRE 36X36
 ALUWINKEL 36X36

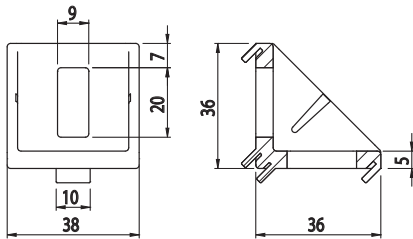
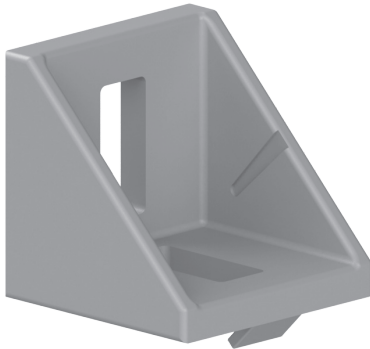

Cod	Note	g
084.305.040	Assembly with M8x20 screws, not included - Montaggio con viti M8x20 non incluse - Montaje con tornillos M8x20, no incluidos - Montage avec vis M8x20 non fournies - Montage mit Schrauben M8x20 nicht im Lieferumfang enthalten	28

Sandblasted aluminium

Alluminio sabbiato
 Aluminio arenado
 Aluminium sablé
 Sandgestrahltes Aluminium

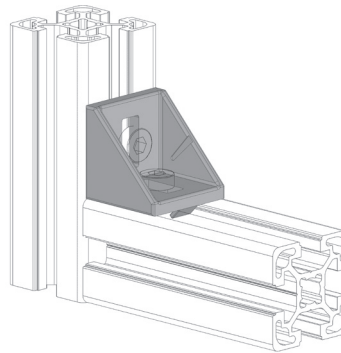

Cap - Tappo - Tapòn - Embout - Abdeckkappe			
Cod	Mat	g	Col
084.206.009	PA	9	■

36X36 BRACKET

ANGOLARE 36X36
 ESCUADRA 36X36
 EQUERRE 36X36
 ALUWINKEL 36X36

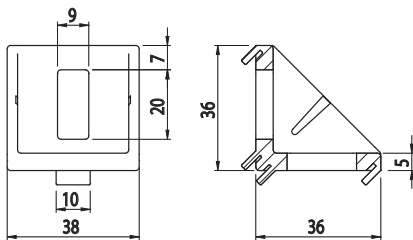
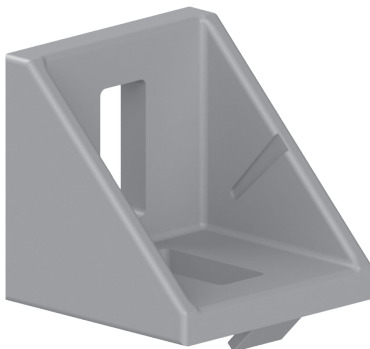

Cod	Note	g
084.305.040T	Assembly with M8x20 screws, not included - Montaggio con viti M8x20 non incluse - Montaje con tornillos M8x20, no incluidos - Montage avec vis M8x20 non fournies - Montage mit Schrauben M8x20 nicht im Lieferumfang enthalten	28

Tumbled aluminium

Alluminio burattato
 Aluminio vibroacabado
 Aluminium tribofini
 Gleitgeschliffene Aluminium

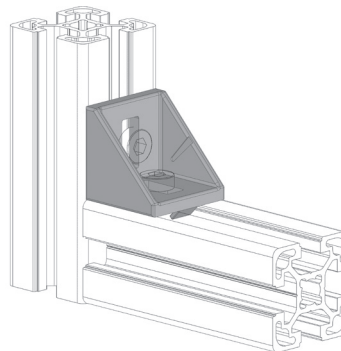

Cap - Tappo - Tapòn - Embout - Abdeckkappe			
Cod	Mat	g	Col
084.206.009	PA	9	■

**37X78 BRACKET**

ANGOLARE 37X78
 ESCUADRA 37X78
 EQUERRE 37X78
 ALUWINKEL 37X78

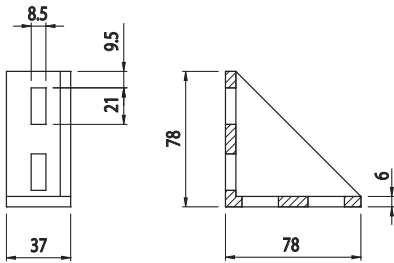
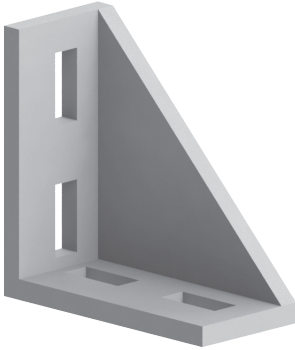

Cod	Note	g
084.305.024	Assembly with M8x20 screws, not included - Montaggio con viti M8x20 non incluse - Montaje con tornillos M8x20, no incluidos - Montage avec vis M8x20 non fournies - Montage mit Schrauben M8x20 (nicht im Lieferumfang enthalten)	115

Sandblasted aluminium

Alluminio sabbiato
 Aluminio arenado
 Aluminium sablé
 Sandgestrahltes Aluminium

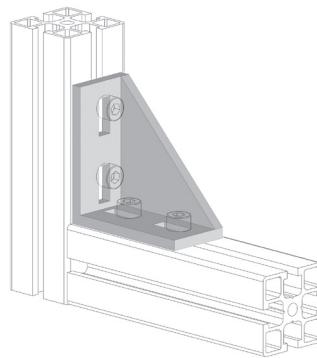
**37X78 BRACKET**

ANGOLARE 37X78
 ESCUADRA 37X78
 EQUERRE 37X78
 ALUWINKEL 37X78

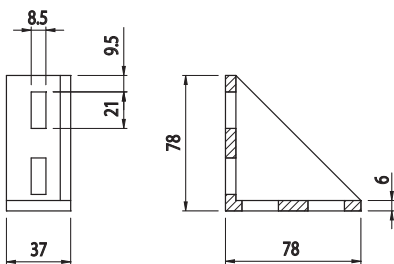
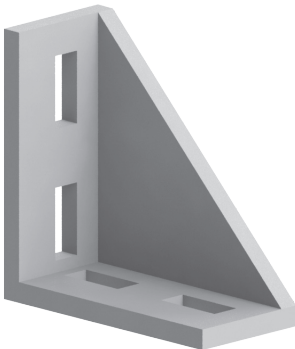

Cod	Note	g
084.305.024T	Assembly with M8x20 screws, not included - Montaggio con viti M8x20 non incluse - Montaje con tornillos M8x20, no incluidos - Montage avec vis M8x20 non fournies - Montage mit Schrauben M8x20 (nicht im Lieferumfang enthalten)	115

Tumbled zamak

Zama burattato
 Zamak vibroacabado
 Zamak tribofini
 Gleitgeschliffene Zamak-Legierung

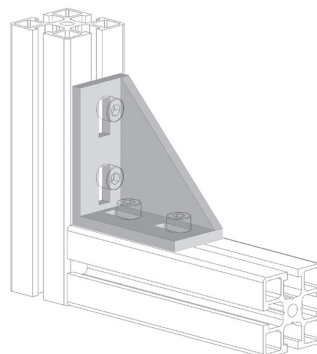



78X78 BRACKET

ANGOLARE 78X78
 ESCUADRA 78X78
 EQUERRE 78X78
 ALUWINKEL 78X78

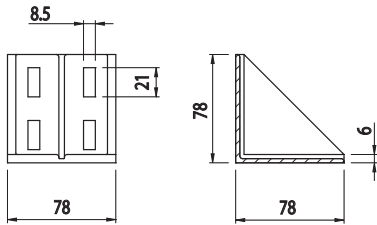
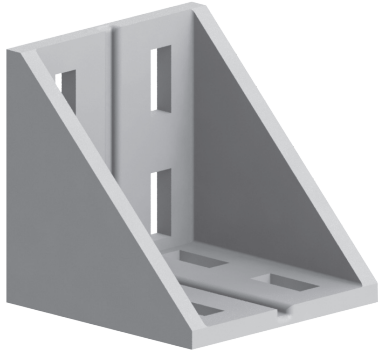

Cod	Note	g
084.305.022	Assembly with M8x20 screws, not included - Montaggio con viti M8x20 non incluse - Montaje con tornillos M8x20, no incluidos - Montage avec vis M8x20 non fournies - Montage mit Schrauben M8x20 (nicht im Lieferumfang enthalten)	234

Sandblasted aluminium

Alluminio sabbiato
 Aluminio arenado
 Aluminium sablé
 Sandgestrahltes Aluminium

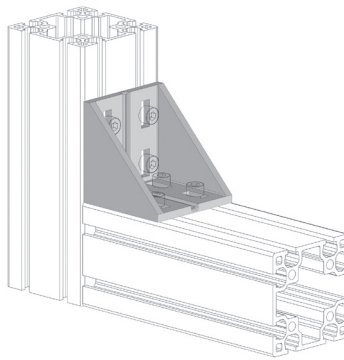

43X43 BRACKET

ANGOLARE 43X43
 ESCUADRA 43X43
 EQUERRE 43X43
 ALUWINKEL 43X43

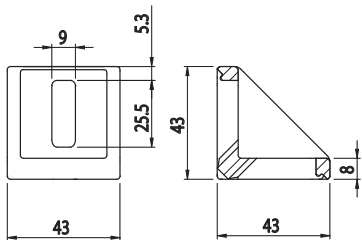
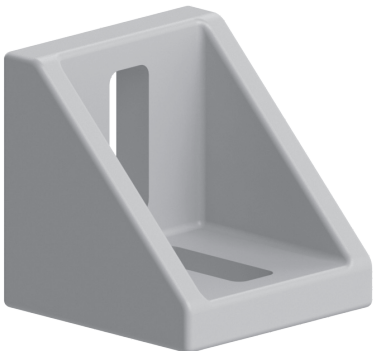

Cod	Note	g
084.305.003	Assembly with M8x20 screws, not included - Montaggio con viti M8x20 non incluse - Montaje con tornillos M8x20, no incluidos - Montage avec vis M8x20 non fournies - Montage mit Schrauben M8x20 (nicht im Lieferumfang enthalten)	60

Sandblasted aluminium

Alluminio sabbiato
 Aluminio arenado
 Aluminium sablé
 Sandgestrahltes Aluminium

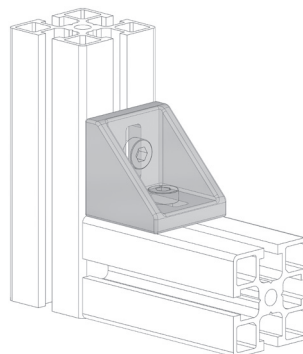

Cap - Tappo - Tapón - Embout - Abdeckkappe			
Cod	Mat	g	Col
084.206.003	PA	7	■
084.206.003G	PA	7	■

**43X43 BRACKET**

ANGOLARE 43X43
 ESCUADRA 43X43
 EQUERRE 43X43
 ALUWINKEL 43X43

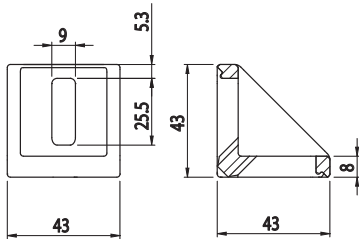
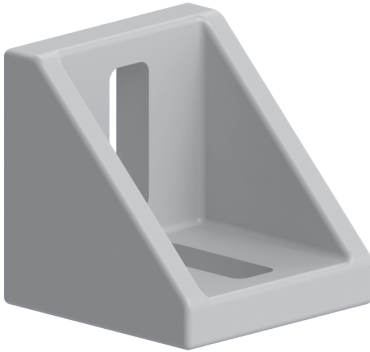

Cod	Note	g
084.305.003T	Assembly with M8x20 screws, not included - Montaggio con viti M8x20 non incluse - Montaje con tornillos M8x20, no incluidos - Montage avec vis M8x20 non fournies - Montage mit Schrauben M8x20 (nicht im Lieferumfang enthalten)	60

Tumbled zamak

Zama burattato
 Zamak vibroacabado
 Zamak tribofini
 Gleitgeschliffene Zamak-Legierung

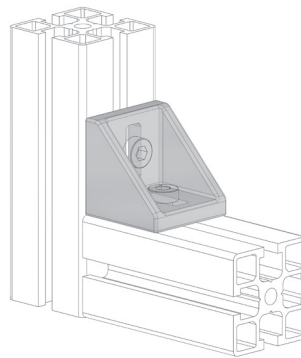

Cap - Tappo - Tapòn - Embout - Abdeckkappe			
		45.5	45.5
Cod	Mat	g	Col
084.206.003	PA	7	■
084.206.003G	PA	7	■

43X43 BRACKET

ANGOLARE 43X43
 ESCUADRA 43X43
 EQUERRE 43X43
 ALUWINKEL 43X43

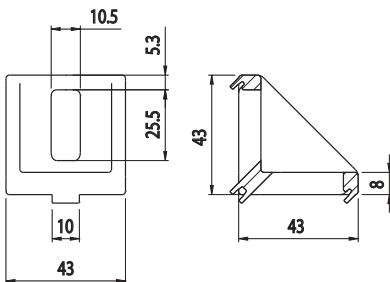
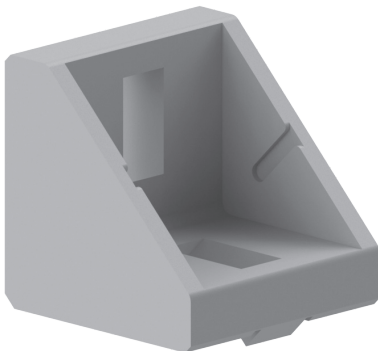

Cod	Note	g
084.305.026	Assembly with M8x20 screws, not included - Montaggio con viti M8x20 non incluse - Montaje con tornillos M8x20, no incluidos - Montage avec vis M8x20 non fournies - Montage mit Schrauben M8x20 nicht im Lieferumfang enthalten	56

Sandblasted aluminium

Alluminio sabbato
 Aluminio arenado
 Aluminium sablé
 Sandgestrahltes Aluminium

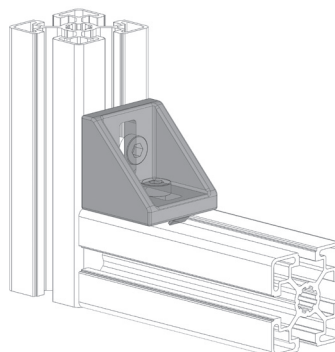

Cap - Tappo - Tapòn - Embout - Abdeckkappe			
		47	47
Cod	Mat	g	Col
084.206.003	PA	7	■
084.206.003G	PA	7	■



43X43 BRACKET

ANGOLARE 43X43
 ESCUADRA 43X43
 EQUERRE 43X43
 ALUWINKEL 43X43

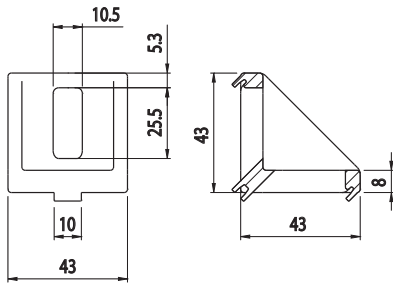
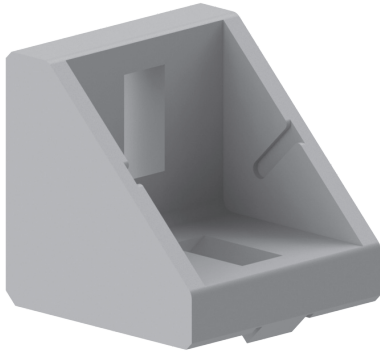

Cod	Note	g
084.305.026T	Assembly with M8x20 screws, not included - Montaggio con viti M8x20 non incluse - Montaje con tornillos M8x20, no incluidos - Montage avec vis M8x20 non fournies - Montage mit Schrauben M8x20 nicht im Lieferumfang enthalten	56

Sandblasted aluminium

Alluminio sabbiato
 Aluminio arenado
 Aluminium sablé
 Sandgestrahltes Aluminium

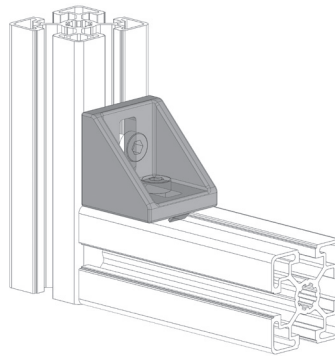

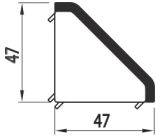
Cap - Tappo - Tapón - Embout - Abdeckkappe			
			
Cod	Mat	g	Col
084.206.003	PA	7	■
084.206.003G	PA	7	■

43X43 BRACKET

ANGOLARE 43X43
 ESCUADRA 43X43
 EQUERRE 43X43
 ALUWINKEL 43X43

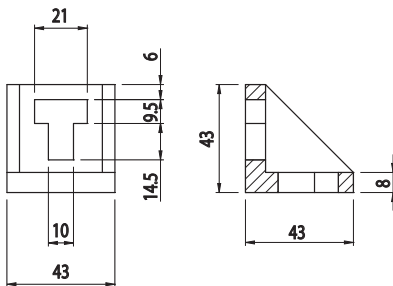
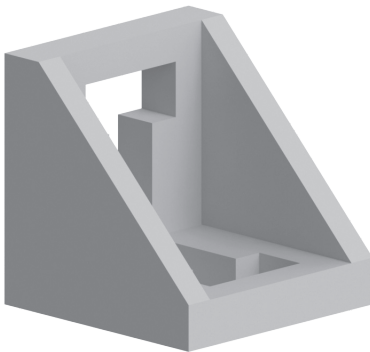

Cod	Note	g
084.305.021	Assembly with M8x20 screws, not included - Montaggio con viti M8x20 non incluse - Montaje con tornillos M8x20, no incluidos - Montage avec vis M8x20 non fournies - Montage mit Schrauben M8x20 (nicht im Lieferumfang enthalten)	60

Sandblasted aluminium

Alluminio sabbiato
 Aluminio arenado
 Aluminium sablé
 Sandgestrahltes Aluminium

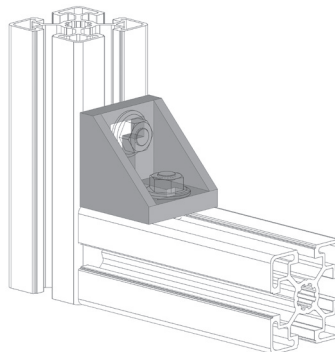

**42X42 BRACKET**

ANGOLARE 42X42
ESCUADRA 42X42
EQUERRE 42X42
ALUWINKEL 42X42

BH
105
50

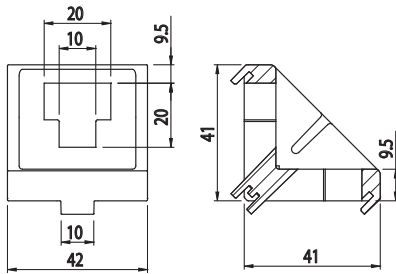
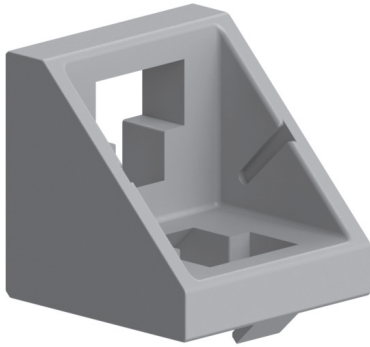

Cod	Note	g
084.305.045	Assembly with M8x20 screws, not included - Montaggio con viti M8x20 non incluse - Montaje con tornillos M8x20, no incluidos - Montage avec vis M8x20 non fournies - Montage mit Schrauben M8x20 (nicht im Lieferumfang enthalten)	54

Sandblasted aluminium

Alluminio sabbiato
Aluminio arenado
Aluminium sablé
Sandgestrahltes Aluminium

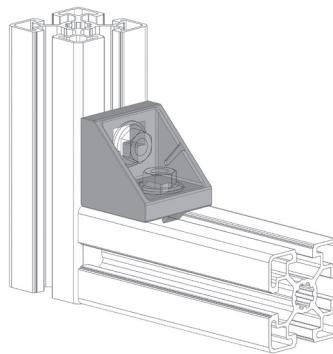

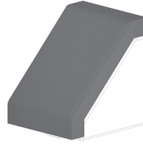
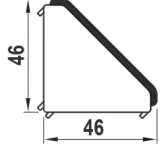
Cap - Tappo - Tapòn - Embout - Abdeckkappe			
			
Cod	Mat	g	Col
084.206.011	PA	8,6	■

42X42 BRACKET

ANGOLARE 42X42
ESCUADRA 42X42
EQUERRE 42X42
ALUWINKEL 42X42

BH
105
50

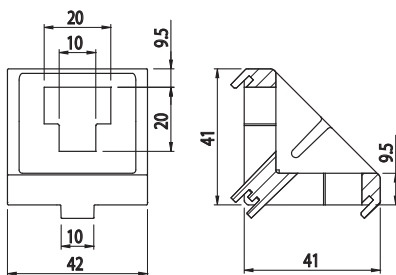
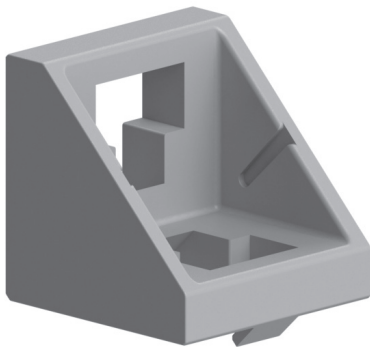

Cod	Note	g
084.305.045T	Assembly with M8x20 screws, not included - Montaggio con viti M8x20 non incluse - Montaje con tornillos M8x20, no incluidos - Montage avec vis M8x20 non fournies - Montage mit Schrauben M8x20 (nicht im Lieferumfang enthalten)	54

Sandblasted aluminium

Alluminio sabbiato
Aluminio arenado
Aluminium sablé
Sandgestrahltes Aluminium

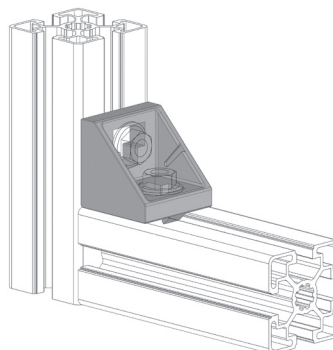

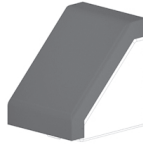
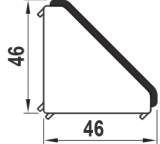
Cap - Tappo - Tapòn - Embout - Abdeckkappe			
			
Cod	Mat	g	Col
084.206.011	PA	8,6	■



43X86 BRACKET

ANGOLARE 43X86
ESCUADRA 43X86
EQUERRE 43X86
ALUWINKEL 43X86

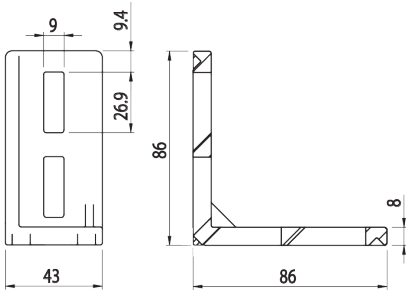

Cod	Note	g
084.305.033	Assembly with M8x20 screws, not included - Montaggio con viti M8x20 non incluse - Montaje con tornillos M8x20, no incluidos - Montage avec vis M8x20 non fournies - Montage mit Schrauben M8x20 (nicht im Lieferumfang enthalten)	160

Sandblasted aluminium

Alluminio sabbiato
Aluminio arenado
Aluminium sablé
Sandgestrahltes Aluminium

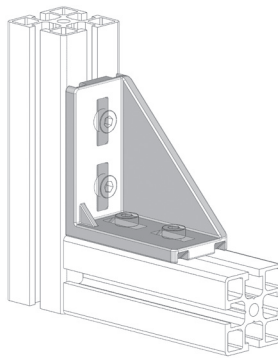

Cap - Tappo - Tapòn - Embout - Abdeckkappe			
		88.5	88.5
Cod	Mat	g	Col
084.206.005	PA	34	■

43X86 BRACKET

ANGOLARE 43X86
ESCUADRA 43X86
EQUERRE 43X86
ALUWINKEL 43X86

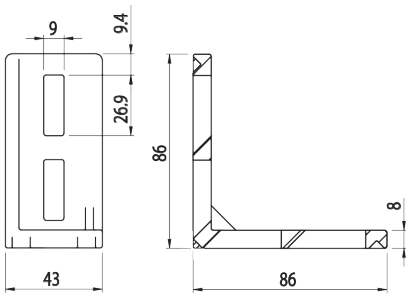
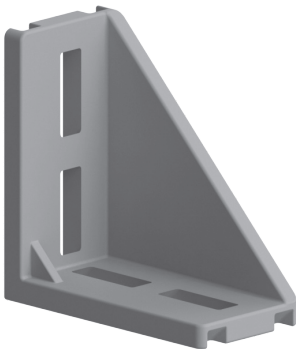

Cod	Note	g
084.305.033T	Assembly with M8x20 screws, not included - Montaggio con viti M8x20 non incluse - Montaje con tornillos M8x20, no incluidos - Montage avec vis M8x20 non fournies - Montage mit Schrauben M8x20 (nicht im Lieferumfang enthalten)	160

Tumbled aluminium

Alluminio burattato
Aluminio vibroacabado
Aluminium tribofini
Gleitgeschliffene Aluminium

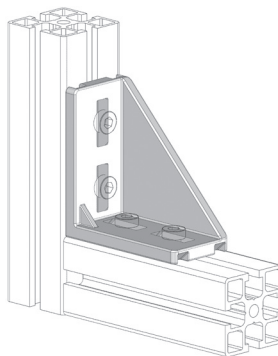

Cap - Tappo - Tapòn - Embout - Abdeckkappe			
		88.5	88.5
Cod	Mat	g	Col
084.206.005	PA	34	■

**43X86 BRACKET**

ANGOLARE 43X86
 ESCUADRA 43X86
 EQUERRE 43X86
 ALUWINKEL 43X86

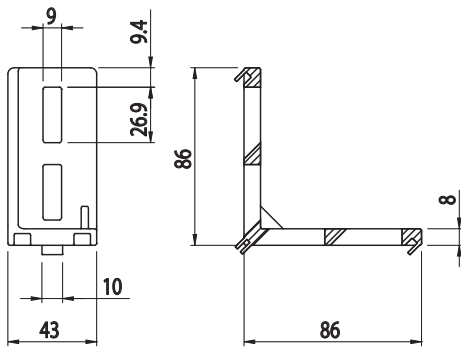
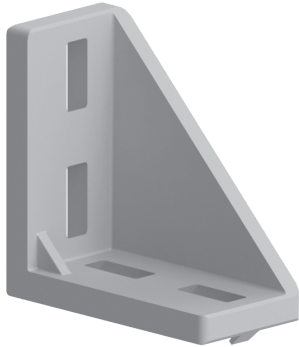

Cod	Note	g
084.305.028	Assembly with M8x20 screws, not included - Montaggio con viti M8x20 non incluse - Montaje con tornillos M8x20, no incluidos - Montage avec vis M8x20 non fournies - Montage mit Schrauben M8x20 nicht im Lieferumfang enthalten	162

Sandblasted aluminium

Alluminio sabbiato
 Aluminio arenado
 Aluminium sablé
 Sandgestrahltes Aluminium

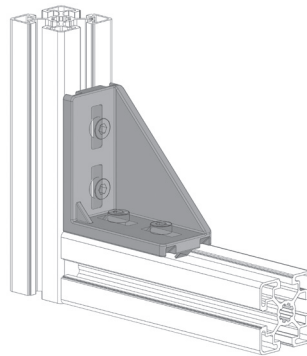

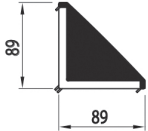
Cap - Tappo - Tapòn - Embout - Abdeckkappe			
			
Cod	Mat	g	Col
084.206.005	PA	34	■

43X86 BRACKET

ANGOLARE 43X86
 ESCUADRA 43X86
 EQUERRE 43X86
 ALUWINKEL 43X86

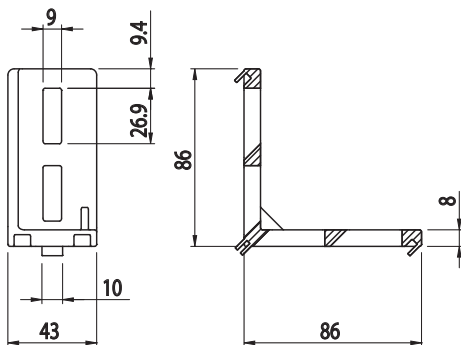
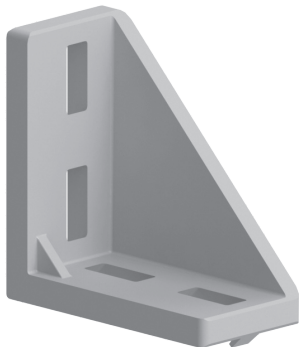

Cod	Note	g
084.305.028T	Assembly with M8x20 screws, not included - Montaggio con viti M8x20 non incluse - Montaje con tornillos M8x20, no incluidos - Montage avec vis M8x20 non fournies - Montage mit Schrauben M8x20 nicht im Lieferumfang enthalten	162

Tumbled aluminium

Alluminio burattato
 Aluminio vibroacabado
 Aluminium tribofini
 Gleitgeschliffene Aluminium

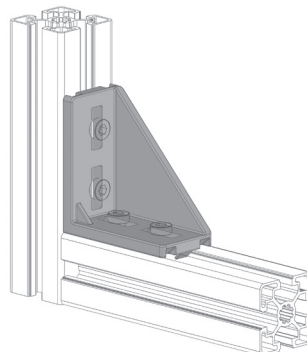

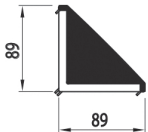
Cap - Tappo - Tapòn - Embout - Abdeckkappe			
			
Cod	Mat	g	Col
084.206.005	PA	34	■



86X86 BRACKET

ANGOLARE 86X86
ESCUADRA 86X86
EQUERRE 86X86
ALUWINKEL 86X86

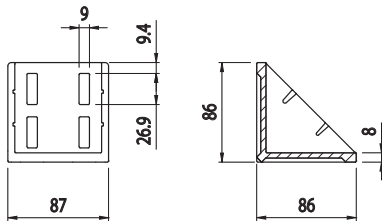
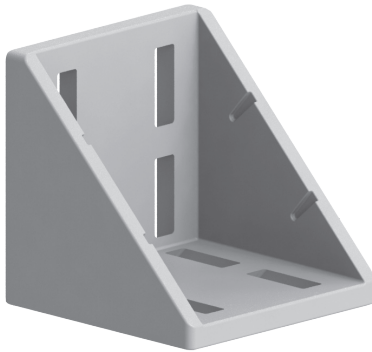

Cod	Note	g
084.305.034	Assembly with M8x20 screws, not included - Montaggio con viti M8x20 non incluse - Montaje con tornillos M8x20, no incluidos - Montage avec vis M8x20 non fournies - Montage mit Schrauben M8x20 (nicht im Lieferumfang enthalten)	350

Sandblasted aluminium

Alluminio sabbiato
Aluminio arenado
Aluminium sablé
Sandgestrahltes Aluminium

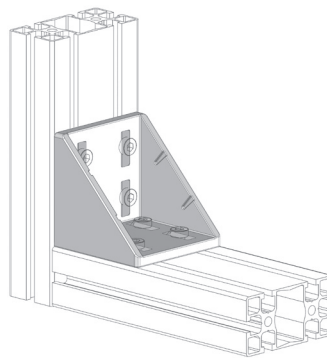

Cap - Tappo - Tapòn - Embout - Abdeckkappe			
Cod	Mat	g	Col
084.206.006	PA	30	■

86X86 BRACKET

ANGOLARE 86X86
ESCUADRA 86X86
EQUERRE 86X86
ALUWINKEL 86X86

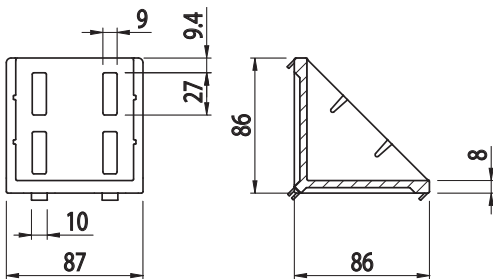
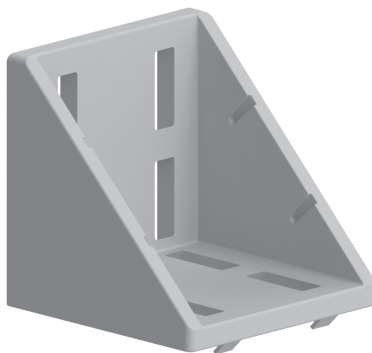

Cod	Note	g
084.305.030	Assembly with M8x20 screws, not included - Montaggio con viti M8x20 non incluse - Montaje con tornillos M8x20, no incluidos - Montage avec vis M8x20 non fournies - Montage mit Schrauben M8x20 nicht im Lieferumfang enthalten	334

Sandblasted aluminium

Alluminio sabbiato
Aluminio arenado
Aluminium sablé
Sandgestrahltes Aluminium

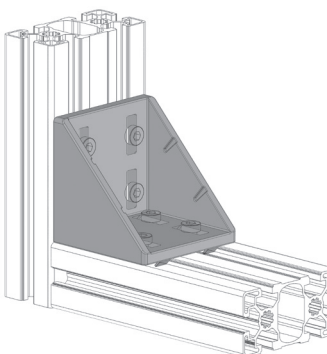

Cap - Tappo - Tapòn - Embout - Abdeckkappe			
Cod	Mat	g	Col
084.206.006	PA	30	■

**43X88 BRACKET**

ANGOLARE 43X88
ESCUADRA 43X88
EQUERRE 43X88
ALUWINKEL 43X88

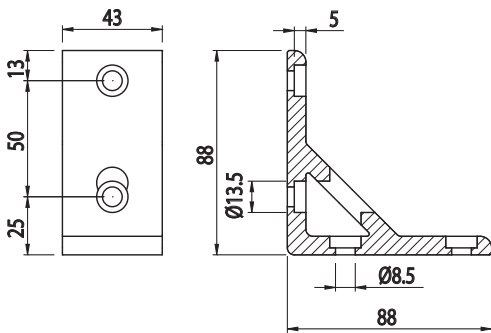

Cod	Note	g
084.305.042	Assembly with M8x16 screws, not included - Montaggio con viti M8x16 non incluse - Montaje con tornillos M8x16, no incluidos - Montage avec vis M8x16 non fournies - Montage mit Schrauben M8x16 nicht im Lieferumfang enthalten	22

Anodised aluminium

Alluminio anodizzato
Aluminio anodizado
Aluminium anodisé
Eloxiertes Aluminium

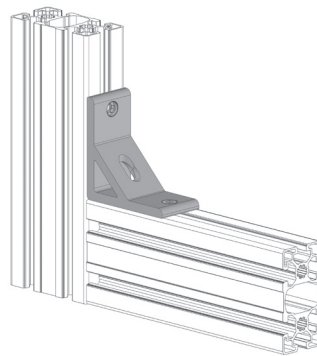
**88X88 BRACKET**

ANGOLARE 88X88
ESCUADRA 88X88
EQUERRE 88X88
ALUWINKEL 88X88

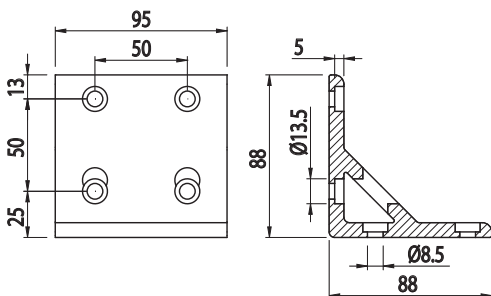
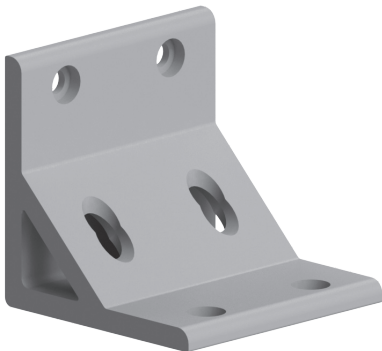

Cod	Note	g
084.305.043	Assembly with M8x16 screws, not included - Montaggio con viti M8x16 non incluse - Montaje con tornillos M8x16, no incluidos - Montage avec vis M8x16 non fournies - Montage mit Schrauben M8x16 nicht im Lieferumfang enthalten	44

Anodised aluminium

Alluminio anodizzato
Aluminio anodizado
Aluminium anodisé
Eloxiertes Aluminium

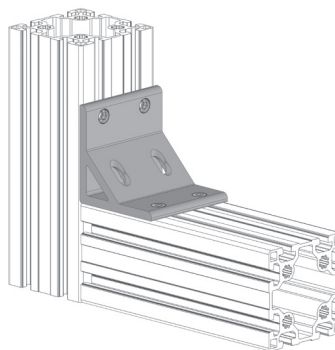



40X40 BRACKET

ANGOLARE 40X40
ESCUADRA 40X40
EQUERRE 40X40
ALUWINKEL 40X40

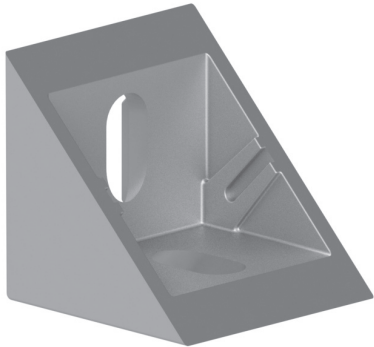

Cod	Note	g
084.305.047	Assembly with M8x16 screws, not included - Montaggio con viti M8x16 non incluse - Montaje con tornillos M8x16, no incluidos - Montage avec vis M8x16 non fournies - Montage mit Schrauben M8x16 (nicht im Lieferumfang enthalten)	77

Grey painted RAL 9006 zamak

Zama verniciato grigio RAL 9006
Zamak barnizado en gris RAL 9006
Zamak peint gris RAL 9006
Grau lackierte RAL-Farbe 9006 Zamak-Legierung

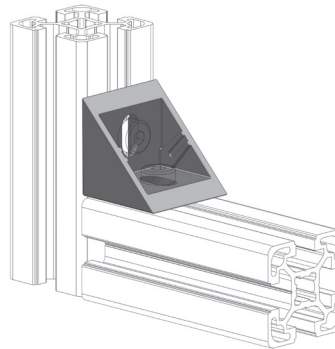
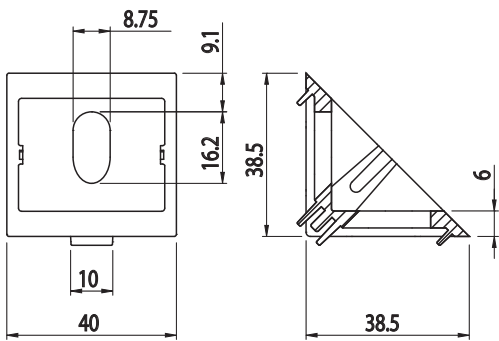

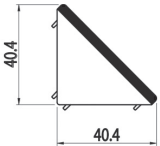
Cap - Tappo - Tapòn - Embout - Abdeckkappe			
			
Cod	Mat	g	Col
084.206.010	PA	8,6	■

40X40 BRACKET

ANGOLARE 40X40
ESCUADRA 40X40
EQUERRE 40X40
ALUWINKEL 40X40

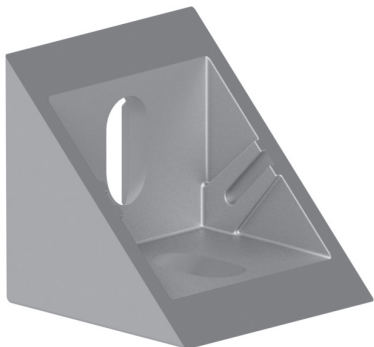

Cod	Note	g
084.305.047T	Assembly with M8x16 screws, not included - Montaggio con viti M8x16 non incluse - Montaje con tornillos M8x16, no incluidos - Montage avec vis M8x16 non fournies - Montage mit Schrauben M8x16 (nicht im Lieferumfang enthalten)	77

Tumbled zamak

Zama burattato
Zamak vibroacabado
Zamak tribofini
Gleitgeschliffene Zamak-Legierung

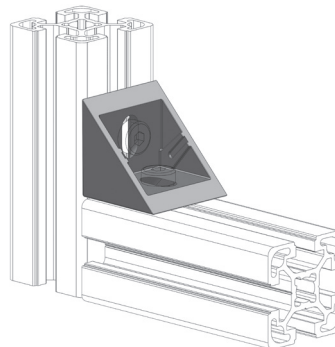
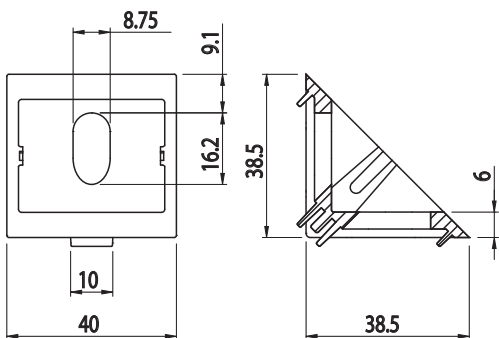

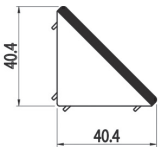
Cap - Tappo - Tapòn - Embout - Abdeckkappe			
			
Cod	Mat	g	Col
084.206.010	PA	8,6	■

**40X80 BRACKET**

ANGOLARE 40X80
ESCUADRA 40X80
EQUERRE 40X80
ALUWINKEL 40X80

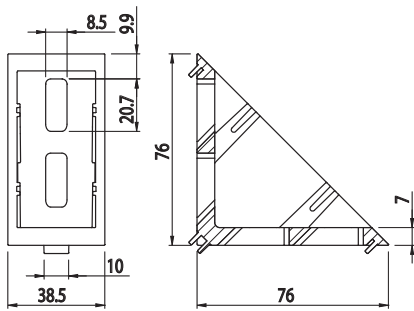
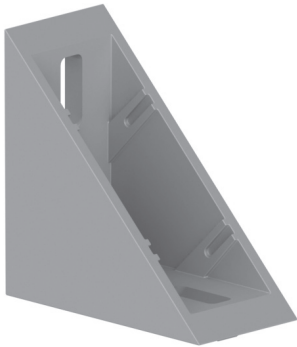

Cod	Note	g
084.305.049	Assembly with M8x16 screws, not included - Montaggio con viti M8x16 non incluse - Montaje con tornillos M8x16, no incluidos - Montage avec vis M8x16 non fournies - Montage mit Schrauben M8x16 (nicht im Lieferumfang enthalten)	270

Grey painted RAL 9006 zamak

Zama verniciato grigio RAL 9006
Zamak barnizado en gris RAL 9006
Zamak peint gris RAL 9006
Grau lackierte RAL-Farbe 9006 Zamak-Legierung

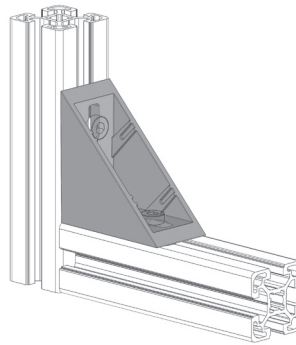

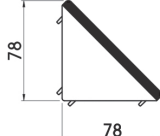
Cap - Tappo - Tapòn - Embout - Abdeckkappe			
			
Cod	Mat	g	Col
084.206.012	PA	20	■

40X80 BRACKET

ANGOLARE 40X80
ESCUADRA 40X80
EQUERRE 40X80
ALUWINKEL 40X80

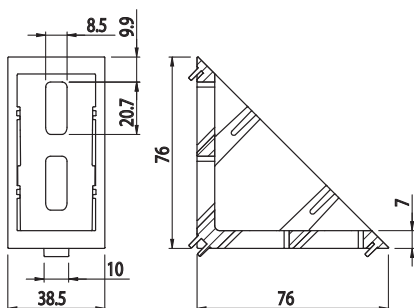
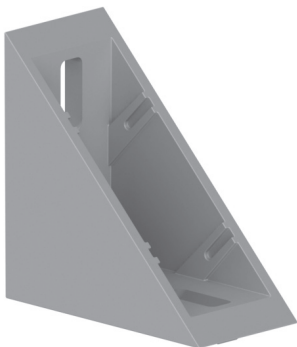

Cod	Note	g
084.305.049T	Assembly with M8x16 screws, not included - Montaggio con viti M8x16 non incluse - Montaje con tornillos M8x16, no incluidos - Montage avec vis M8x16 non fournies - Montage mit Schrauben M8x16 (nicht im Lieferumfang enthalten)	270

Tumbled zamak

Zama burattato
Zamak vibroacabado
Zamak tribofini
Gleitgeschliffene Zamak-Legierung

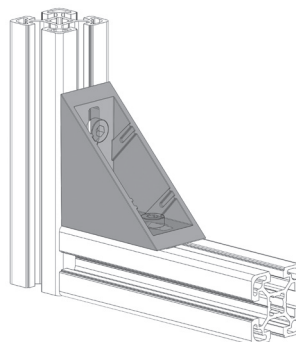

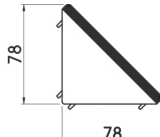
Cap - Tappo - Tapòn - Embout - Abdeckkappe			
			
Cod	Mat	g	Col
084.206.012	PA	20	■



20X20 BRACKET

ANGOLARE 20X20
ESCUADRA 20X20
EQUERRE 20X20
ALUWINKEL 20X20

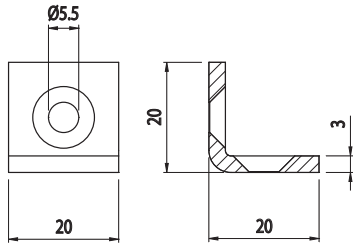
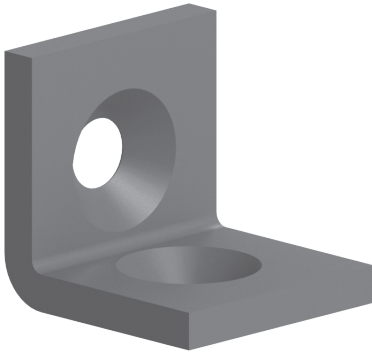

Cod	Note	g
084.305.037	Assembly with M5 screws, not included - Montaggio con viti M5 non incluse - Montaje con tornillos M5, no incluidos - Montage avec vis M5 non fournies - Montage mit Schrauben M5 (nicht im Lieferumfang enthalten)	13

Black painted steel

Acciaio verniciato nero
Acero barnizado en negro
Acier peint noir
Stahl schwarz lackiert

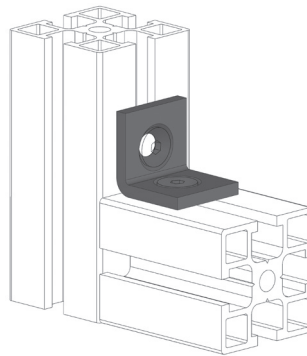

30X30 BRACKET

ANGOLARE 30X30
ESCUADRA 30X30
EQUERRE 30X30
ALUWINKEL 30X30

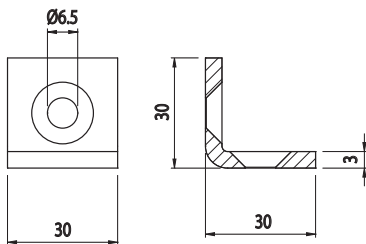
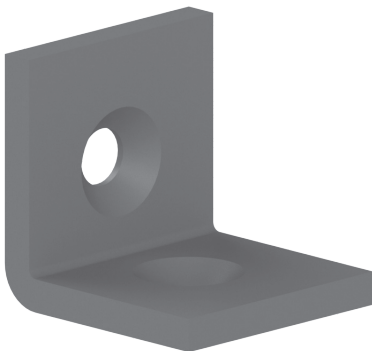

Cod	Note	g
084.305.038	Assembly with M6 screws, not included - Montaggio con viti M6 non incluse - Montaje con tornillos M6, no incluidos - Montage avec vis M6 non fournies - Montage mit Schrauben M6 (nicht im Lieferumfang enthalten)	41

Black painted steel

Acciaio verniciato nero
Acero barnizado en negro
Acier peint noir
Stahl schwarz lackiert

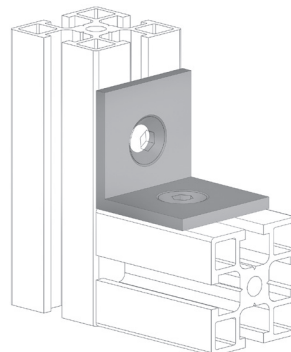

**40X40 BRACKET**

ANGOLARE 40X40
 ESCUADRA 40X40
 EQUERRE 40X40
 ALUWINKEL 40X40

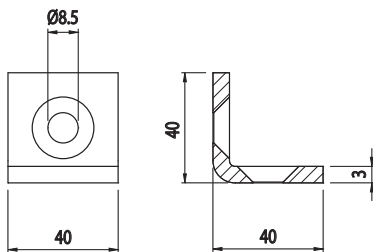
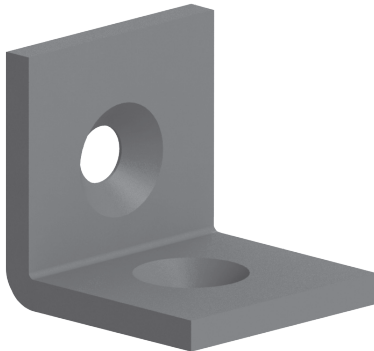

Cod	Note	g
084.305.039	Assembly with M8 screws, not included - Montaggio con viti M8 non incluse - Montaje con tornillos M8, no incluidos - Montage avec vis M8 non fournies - Montage mit Schrauben M8 (nicht im Lieferumfang enthalten)	80

Black painted steel

Acciaio verniciato nero
 Acero barnizado en negro
 Acier peint noir
 Stahl schwarz lackiert

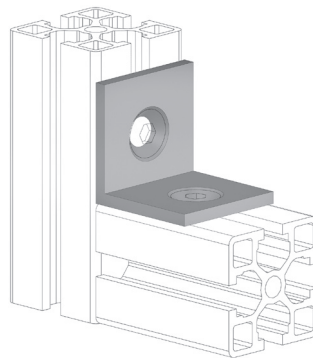
**30X30 BRACKET**

ANGOLARE 30X30
 ESCUADRA 30X30
 EQUERRE 30X30
 ALUWINKEL 30X30

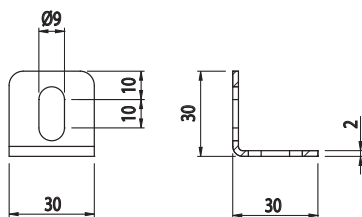
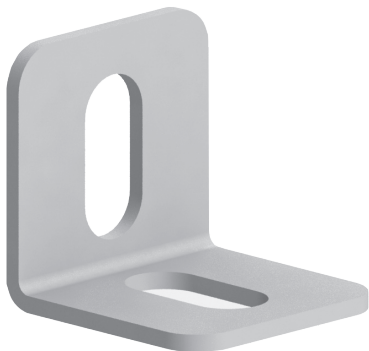

STAINLESS STEEL

Cod	Note	g
084.305.016	Assembly with M8x16 screws, not included - Montaggio con viti M8x16 non incluse - Montaje con tornillos M8x16, no incluidos - Montage avec vis M8x16 non fournies - Montage mit Schrauben M8x16 (nicht im Lieferumfang enthalten)	23

Stainless steel

Acciaio inox
 Acero inoxidable
 Acier inox
 Rostfreier Stahl

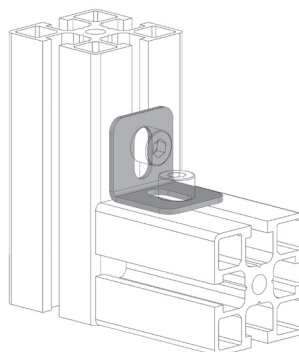



30X30 BRACKET

ANGOLARE 30X30
ESCUADRA 30X30
EQUERRE 30X30
ALUWINKEL 30X30

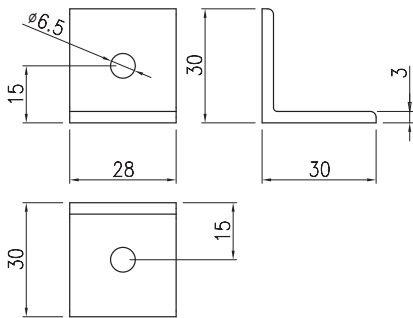
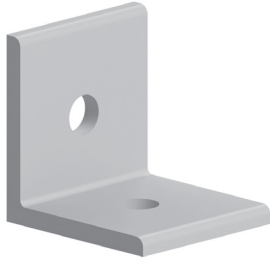

NEW

Cod	Note	g
084.305.057	Assembly with M6 screws, not included - Montaggio con viti M6 non incluse - Montaje con tornillos M6, no incluidos - Montage avec vis M6 non fournies - Montage mit Schrauben M6 (nicht im Lieferumfang enthalten)	12

Tumbled aluminium

Alluminio burattato
Aluminio vibroacabado
Aluminium tribofini
Gleitgeschliffene Aluminium

40X40 BRACKET

ANGOLARE 40X40
ESCUADRA 40X40
EQUERRE 40X40
ALUWINKEL 40X40

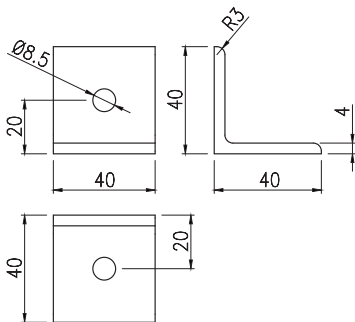
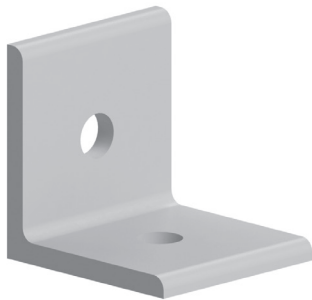

Cod	Note	g
084.305.056	Assembly with M5 screws, not included - Montaggio con viti M5 non incluse - Montaje con tornillos M5, no incluidos - Montage avec vis M5 non fournies - Montage mit Schrauben M5 (nicht im Lieferumfang enthalten)	30

Steel

Acciaio
Acero
Acier
Stahl

**PLATE FOR FEET AND WHEELS**

PIASTRA PER PIEDI E RUOTE
 PLETINA PARA PIES Y RUEDAS
 PLAQUE POUR PIEDES ET ROUES
 PLATTE FÜR FÜSSE UND RÄDER

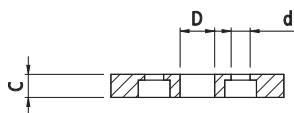
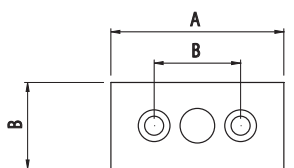
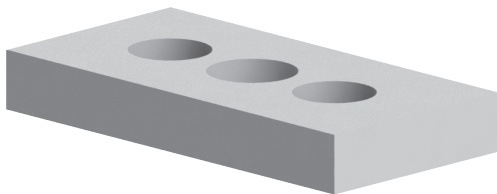

Cod	Note	d	A	D	B	s	g
084.405.023		8,50	60	M12	30	8	32
084.405.027		8,5	80	M12	40	12	80
084.405.005		8,5	80	M16	40	12	80
084.405.010		8,5	90	M10	45	12	85
084.405.013		8,5	90	M12	45	12	84
084.405.001		8,5	90	M16	45	12	83
084.405.011		8,5	90	M20	45	12	80
084.405.004		8,5	90	1/4"	45	12	120
084.405.007		8,5	90	3/8"	45	12	114
084.405.015		8,5	90	1/2"	45	12	110
084.405.016		8,5	90	-	45	10	100
084.405.017		13	100	M10	50	12	133
084.405.018		13	100	M12	50	12	130
084.405.019		13	100	M16	50	12	125
084.405.020		13	100	M20	50	12	120

Aluminium

Alluminio
 Aluminio
 Aluminium
 Aluminium

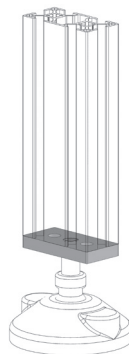



SEAL
GUARNIZIONE
JUNTA
JOINT
DICHTUNG

Cod	Note	g
084.536.001	Seal for 45x90 - Guarnizione di tenuta per 45x90 - Junta de estanqueidad para 45x90 - Joint d'étanchéité pour 45x90 - Dichtung für 45x90	12

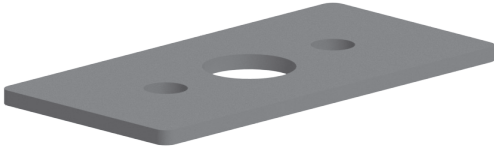

EPDM

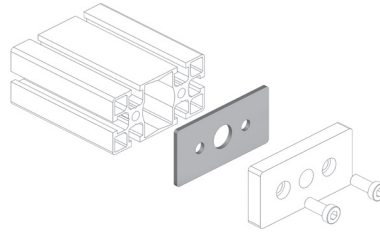
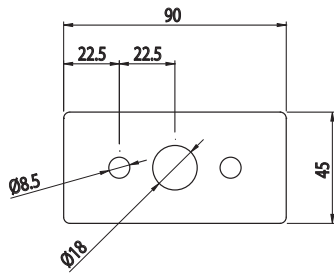
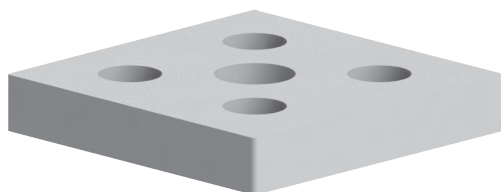



PLATE FOR FEET AND WHEELS

PIASTRA PER PIEDI E RUOTE
 PLETINA PARA PIES Y RUEDAS
 PLAQUE POUR PIEDES ET ROUES
 PLATTE FÜR FÜSSE UND RÄDER



Cod	Note	d	A	D	B	s	g
084.405.024		8,50	60	M12	30	10	85
084.405.006		6,50	80	M16	40	15	234
084.405.025		13	90	M16	45	15	220
084.405.026		13	90	M20	45	15	220
084.405.021		13	100	M16	50	15	420
084.405.022		13	100	M20	50	15	400

Anodised aluminium

Alluminio anodizzato
 Aluminio anodizado
 Aluminium anodisé
 Eloxiertes Aluminium

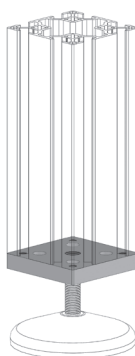
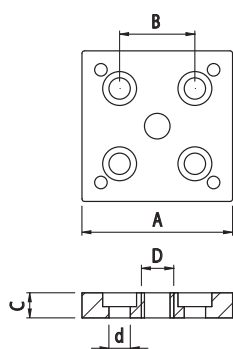



CORNER BRACE

RINFORZO ANGOLARE
REFUERZO ANGULAR
RENFORT D'ANGLE
WINKELFÖRMIGE VERSTÄRKUNG

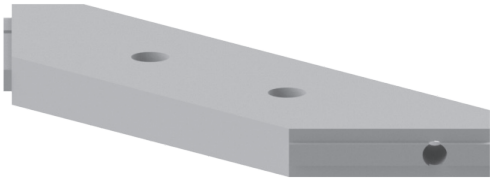

Cod	Note	g
084.406.001	To fasten to the structure with two M8x40 screws - Da fissare alla struttura con due viti M8x40 - Se fija a la estructura con dos tornillos M8x40 - À fixer à la structure avec deux vis M8x40 - Mit zwei Schrauben M8x40 an der Struktur zu befestigen	720

Anodised aluminium

Alluminio anodizzato
Aluminio anodizado
Aluminium anodisé
Eloxiertes Aluminium

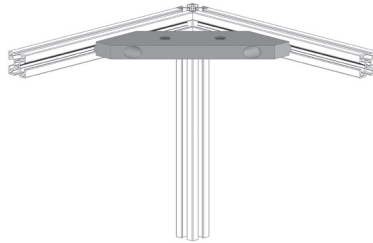
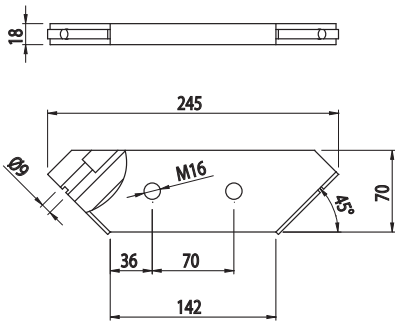

**40X40 TRIPOD FOOT**

TRIPIDE 40X40
TRÍPODE 40X40
TRÉPIED 40X40
DREIFUSS 40X40

BH
105
40



Cod	Note	g
084.408.003	Suitable for M16 articulated feet - Adatto ai piedi snodati M16 - Apto para pies articulados M16 - Adapté aux pieds articulés M16 - Geeignet für Gelenkfüße M16	1010

Black polyamide

Poliammide nero
Poliamida color negro
Polyamide noir
Polyamid schwarz

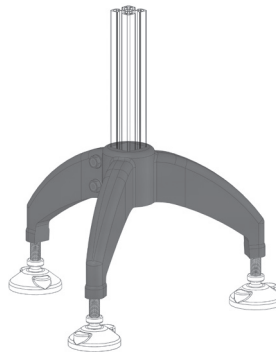
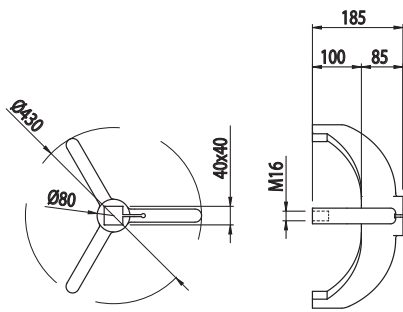
**45X45 TRIPOD FOOT**

TRIPIDE 45X45
TRÍPODE 45X45
TRÉPIED 45X45
DREIFUSS 45X45

BH
105
45



Cod	Note	g
084.408.001	Suitable for M16 articulated feet - Adatto ai piedi snodati M16 - Apto para pies articulados M16 - Adapté aux pieds articulés M16 - Geeignet für Gelenkfüße M16	984

Black polyamide

Poliammide nero
Poliamida color negro
Polyamide noir
Polyamid schwarz

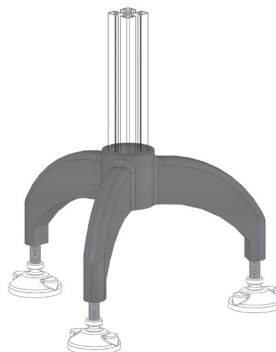
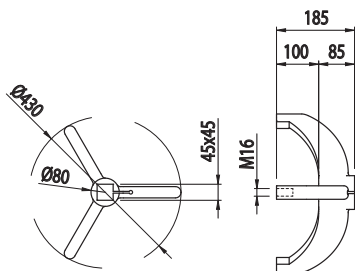



FLOOR BRACKET

STAFFA A PAVIMENTO
ESCUADRA PARA FIJACIÓN EN SUELO
EQUERRE D'ANCRAGE
BODENWINKEL

BH
85
30

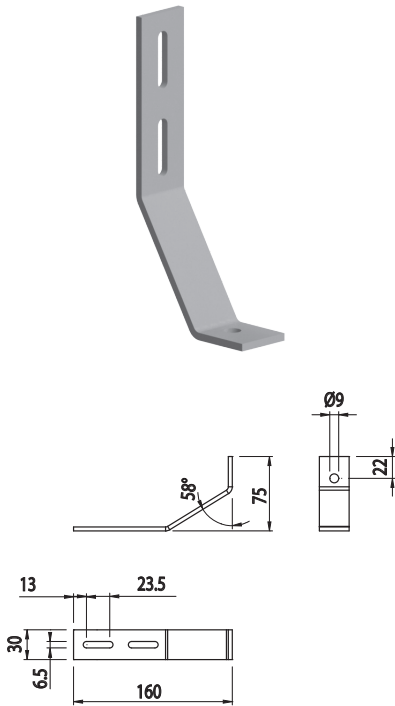

Cod	Note	g
084.409.006	For 30 mm profiles - Per profili 30 mm - Para perfiles de 30 mm - Pour profilés 30 mm - Für Profile 30 mm	173

Grey painted steel

Acciaio verniciato grigio
Acero barnizado en gris
Acier peint gris
Stahl grau lackiert



FLOOR BRACKET

STAFFA A PAVIMENTO
ESCUADRA PARA FIJACIÓN EN SUELO
EQUERRE D'ANCRAGE
BODENWINKEL

BH
105
40

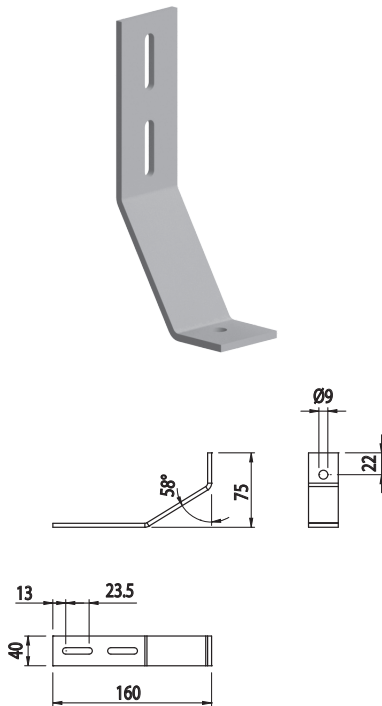

Cod	Note	g
084.409.007	For 40 mm profiles - Per profili 40 mm - Para perfiles de 40 mm - Pour profilés 40 mm - Für Profile 40 mm	242

Grey painted steel

Acciaio verniciato grigio
Acero barnizado en gris
Acier peint gris
Stahl grau lackiert

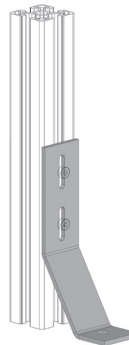

**FLOOR BRACKET**

STAFFA A PAVIMENTO
ESCUADRA PARA FIJACIÓN EN SUELO
EQUERRE D'ANCRAGE
BODENWINKEL

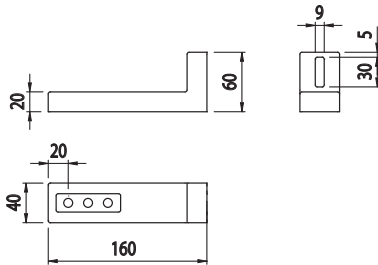
Cod	Note	g
084.409.008	For 40 mm profiles - Per profili 40 mm - Para perfiles de 40 mm - Pour profilés 40 mm - Für Profile 40 mm	208

Black painted Zamak

Zama verniciato nero
Zamak barnizado en negro
Zamak peint noir
Zamak schwarz lackiert

**FLOOR BRACKET**

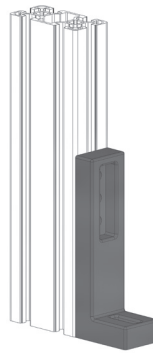
STAFFA A PAVIMENTO
ESCUADRA PARA FIJACIÓN EN SUELO
EQUERRE D'ANCRAGE
BODENWINKEL

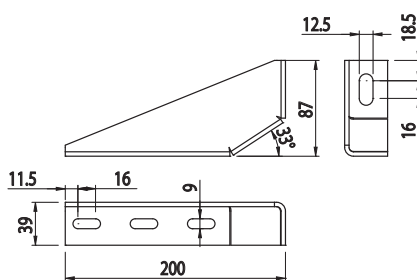
Cod	Note	g
084.409.015	For 40 mm profiles - Per profili 40 mm - Para perfiles de 40 mm - Pour profilés 40 mm - Für Profile 40 mm	520

Galvanised steel

Acciaio zincato
Acero galvanizado
Acier zingué
Verzinkter Stahl



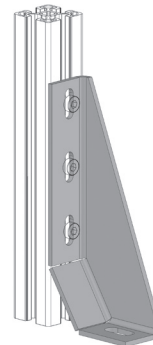

FLOOR BRACKET

STAFFA A PAVIMENTO
ESCUADRA PARA FIJACIÓN EN SUELO
EQUERRE D'ANCRAGE
BODENWINKEL

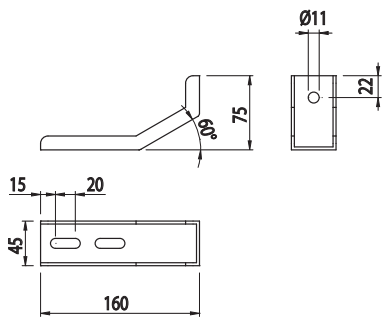

Cod	Note	g
084.409.001	Per profili 45 mm - For 45 mm profiles - Para perfiles de 45 mm - Pour profilés 45 mm - Für Profile 45 mm	303

Grey painted steel

Acciaio verniciato grigio
Acero barnizado en gris
Acier peint gris
Stahl grau lackiert



FLOOR BRACKET

STAFFA A PAVIMENTO
ESCUADRA PARA FIJACIÓN EN SUELO
EQUERRE D'ANCRAGE
BODENWINKEL

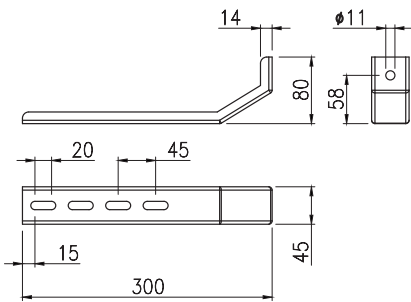

Cod	Note	g
084.409.016	For 45 mm profiles - Per profili 45 mm - Para perfiles de 45 mm - Pour profilés 45 mm - Für Profile 45 mm	303

Grey painted steel

Acciaio verniciato grigio
Acero barnizado en gris
Acier peint gris
Stahl grau lackiert



**LEVELLING FOOT**

PIEDE FISSO
PIE FIJO
PIED FIXE
FESTER STELLFUSS

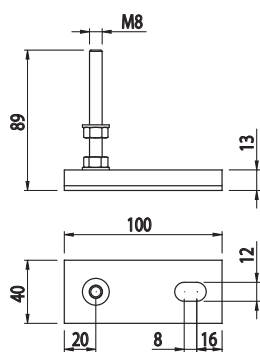
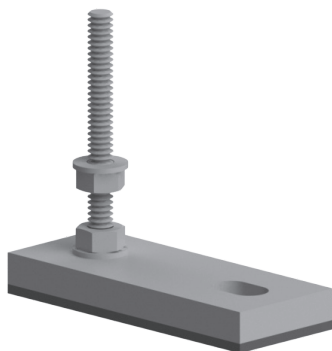

Cod	Note	g
084.408.002	For 45 mm profiles - Per profili 40 e 45 mm - Para perfiles de 45 mm - Pour profilés 45 mm - Für Profile 45 mm	130

Aluminium, EPDM, stainless steel

Alluminio, EPDM, acciaio inox
Aluminio, EPDM, acero inoxidable
Aluminium, EPDM, acier inox
Aluminium, EPDM, rostfreier Stahl

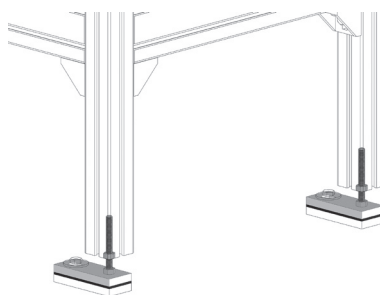



ANTI-SLIP LEVELLING SWIVEL FEET

PIEDI SNODATI ANTIVIBRANTI
PIES ARTICULADOS ANTIVIBRACIÓN
PIEDS ARTICULÉS ANTI-VIBRATION
GELENKSTELLFÜSSE MIT ANTI-SLIP PLATTE

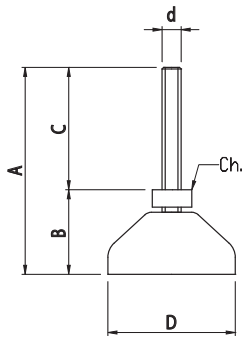

Cod	Kg	D	d	A	B	C	E	F	Ch	g
084.401.004	450	40	M6	65	18	47	-	-	-	26
084.401.001	900	40	M8	68	23	45	-	-	6	29
084.401.002	900	50	M8	88	23	65	-	-	6	39
084.401.003	900	50	M10	95	25	70	-	-	8	55

Black polyamide
Poliammide nero
Poliamida color negro
Polyamide noir
Polyamid schwarz

Galvanized steel
Acciaio zincato
Acero galvanizado
Acier zingúé
Verzinkter Stahl



**ANTI-SLIP LEVELLING SWIVEL FEET**

PIEDI SNODATI ANTIVIBRANTI
 PIES ARTICULADOS ANTIVIBRACIÓN
 PIEDS ARTICULÉS ANTI-VIBRATION
 GELENKSTELLFÜSSE MIT ANTI-SLIP PLATTE

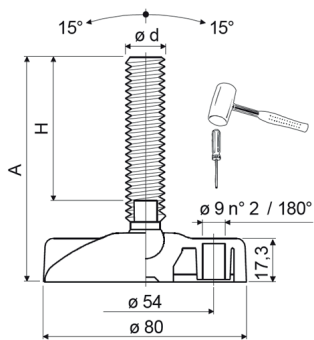

Cod	⚖ Kg	D	d	A	B	C	E	F	Ch	g
084.402.001	1000	80	M8	74	29	45	54	9	6	53
084.402.002	1000	80	M10	101	31	70	54	9	8	75
084.402.003	1000	80	M12	96	33	63	54	9	10	88
084.402.004	1000	80	M16	97	37	60	54	9	13	141
084.402.008	1000	100	M16	165	40	125	74	9	13	240
084.402.005	2200	100	M16	195	40	155	74	10,5	13	293
084.402.006	2200	100	M20	130	44	86	74	10,5	17	303

Black polyamide

Poliammide nero
 Poliamida color negro
 Polyamide noir
 Polyamid schwarz

Galvanized steel

Acciaio zincato
 Acero galvanizado
 Acier zingúé
 Verzinkter Stahl

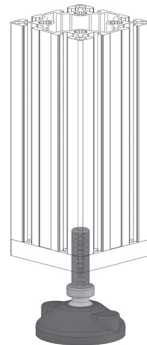



ANTI-SLIP PLATES

ANTIVIBRANTI
PLACAS ANTIDESLIZANTES
PASTILLES ANTI-VIBRATION
ANTI-SLIP PLATTEN

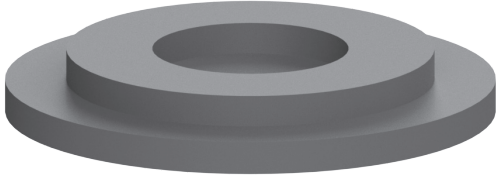

Cod	Note	g
084.403.001	Ø 40	6
084.403.002	Ø 50	12
084.403.003	Ø 80	36
084.403.004	Ø 100	63

Black oil-resistant synthetic rubber

Gomma sintetica antiolio nera
Goma sintética antiaceite color negro
Caoutchouc synthétique anti-huile noir
Ölbeständiger Synthesekautschuk schwarz

**FLOOR MOUNT BASE**

BASE A PAVIMENTO
BASE DE ANCLAJE
EMBASE DE FIXATION
PFOSTENKONSOLE

BH
105
40

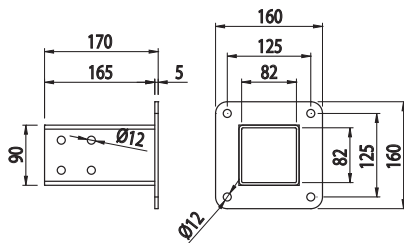

Cod	Note	g
084.410.006	80x80 mm	2360

Grey painted steel

Acciaio verniciato grigio
Acero barnizado en gris
Acier peint gris
Stahl grau lackiert

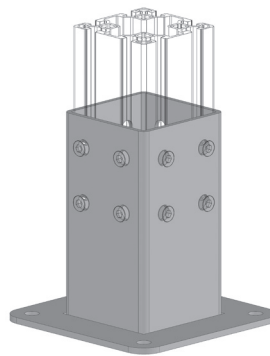
**FLOOR MOUNT BASE**

BASE A PAVIMENTO
BASE DE ANCLAJE
EMBASE DE FIXATION
PFOSTENKONSOLE

BH
105
45

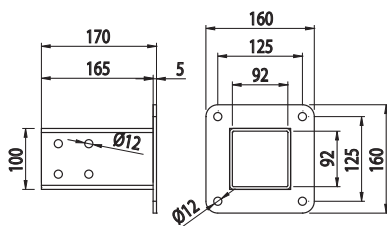

Cod	Note	g
084.410.003	90x90 mm	2364

Grey painted steel

Acciaio verniciato grigio
Acero barnizado en gris
Acier peint gris
Stahl grau lackiert

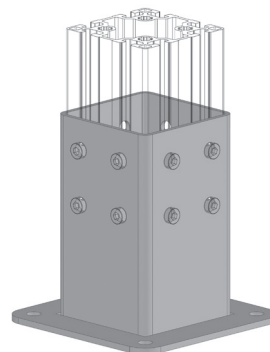



FLOOR MOUNT BASE

BASE A PAVIMENTO
 BASE DE ANCLAJE
 EMBASE DE FIXATION
 PFOSTENKONSOLE

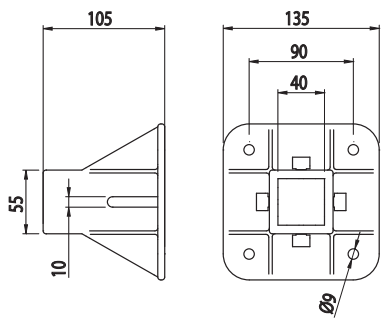
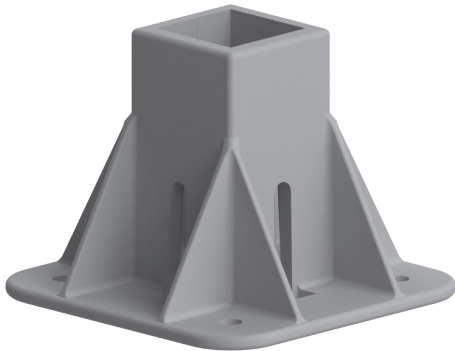

Cod	Note	g
084.409.004	40x40 mm	661

Sandblasted aluminium

Alluminio sabbiato
 Aluminio arenado
 Aluminium sablé
 Sandgestrahltes Aluminium

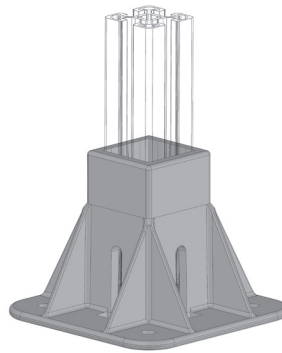

Cap - Tappo - Tapòn - Embout - Abdeckkappe			
Cod	Mat	g	Col
084.207.003	PA	100	■

FLOOR MOUNT BASE

BASE A PAVIMENTO
 BASE DE ANCLAJE
 EMBASE DE FIXATION
 PFOSTENKONSOLE

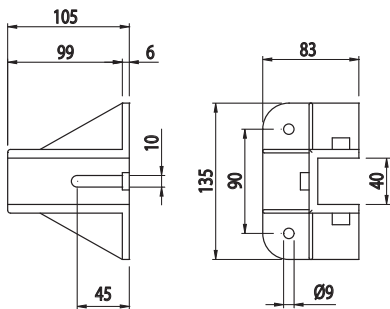
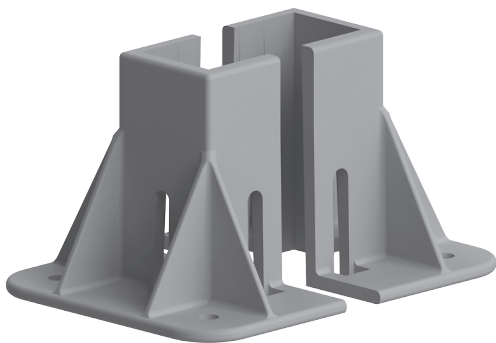

Cod	Note	g
084.409.005	40x80 mm, 40x120 mm	800

Sandblasted aluminium

Alluminio sabbiato
 Aluminio arenado
 Aluminium sablé
 Sandgestrahltes Aluminium

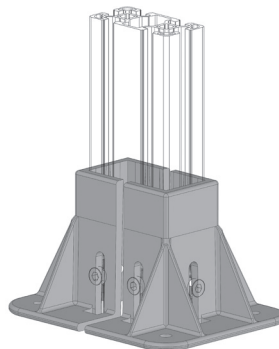

Cap - Tappo - Tapòn - Embout - Abdeckkappe			
Cod	Mat	g	Col
084.207.003	PA	100	■



FLOOR MOUNT BASE

BASE A PAVIMENTO
BASE DE ANCLAJE
EMBASE DE FIXATION
PFOSTENKONSOLE

NEW

Cod	Note	g
084.409.018	60x60 mm	1080

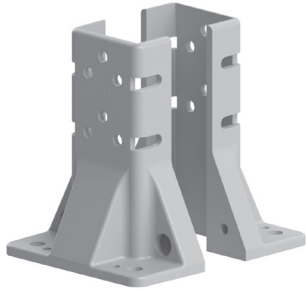

Sandblasted aluminium

Alluminio sabbiato
Aluminio arenado
Aluminium sablé
Sandgestrahltes Aluminium

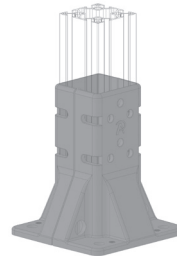
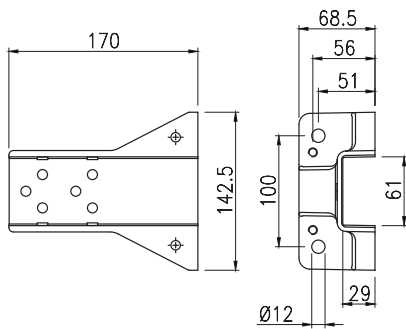

FLOOR MOUNT BASE

BASE A PAVIMENTO
BASE DE ANCLAJE
EMBASE DE FIXATION
PFOSTENKONSOLE

BH
105
40

Cod	Note	g
084.409.014	80x80, 80x120, 80x160 mm	1400

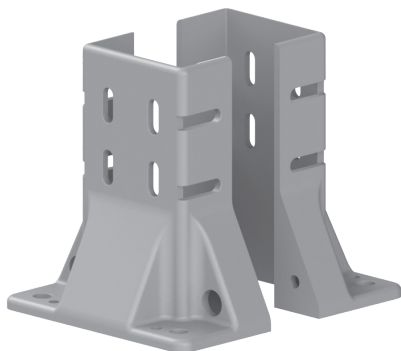

Sandblasted aluminium

Alluminio sabbiato
Aluminio arenado
Aluminium sablé
Sandgestrahltes Aluminium

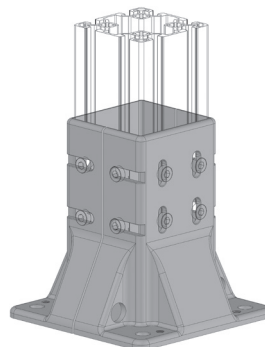
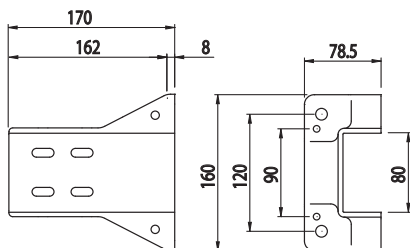



FLOOR MOUNT BASE

BASE A PAVIMENTO
BASE DE ANCLAJE
EMBASE DE FIXATION
PFOSTENKONSOLE

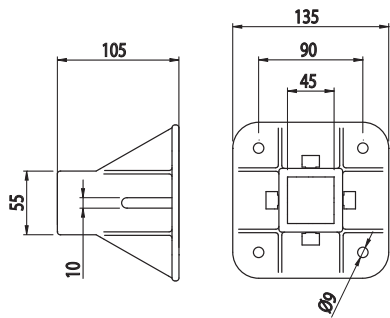
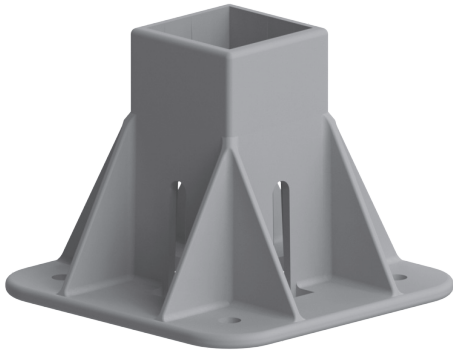

Cod	Note	g
084.409.002	45x45 mm	562

Sandblasted aluminium

Alluminio sabbiato
Aluminio arenado
Aluminium sablé
Sandgestrahltes Aluminium

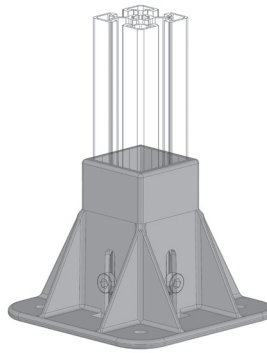

Cap - Tappo - Tapòn - Embout - Abdeckkappe			
Cod	Mat	g	Col
084.207.003	PA	100	■

FLOOR MOUNT BASE

BASE A PAVIMENTO
BASE DE ANCLAJE
EMBASE DE FIXATION
PFOSTENKONSOLE

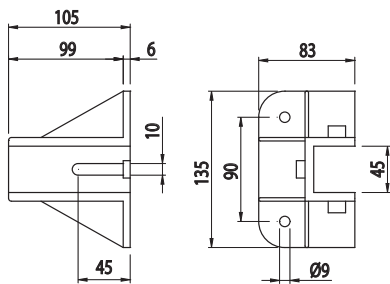
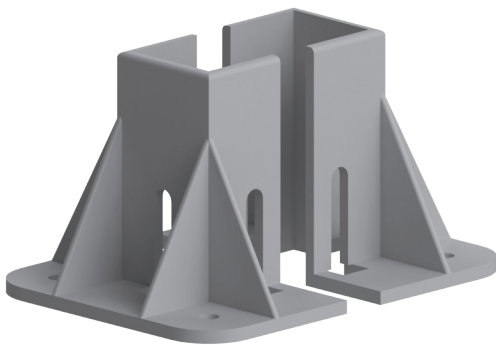

Cod	Note	g
084.409.003	45x90 mm, 45x135 mm, 45x180 mm	672

Sandblasted aluminium

Alluminio sabbiato
Aluminio arenado
Aluminium sablé
Sandgestrahltes Aluminium

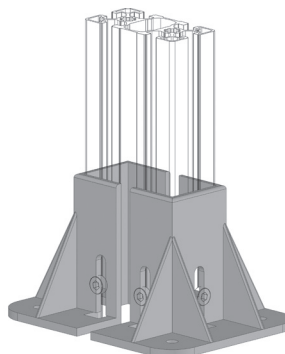

**FLOOR MOUNT BASE**

BASE A PAVIMENTO
BASE DE ANCLAJE
EMBASE DE FIXATION
PFOSTENKONSOLE

BH
105
45

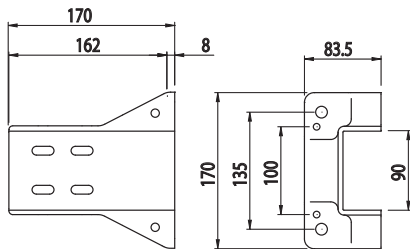
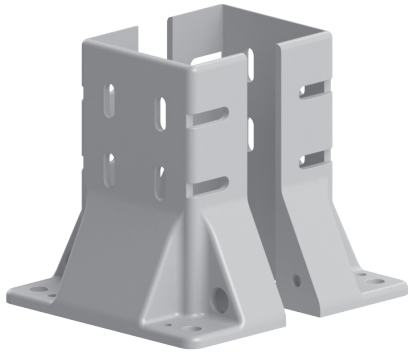

Cod	Note	g
084.409.011	90x90 mm, 90x180 mm	2300

Sandblasted aluminium

Alluminio sabbato
Aluminio arenado
Aluminium sablé
Sandgestrahltes Aluminium

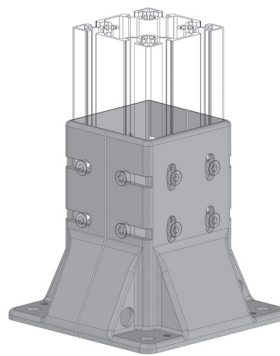
**FLOOR MOUNT BASE**

BASE A PAVIMENTO
BASE DE ANCLAJE
EMBASE DE FIXATION
PFOSTENKONSOLE

BH
105
50

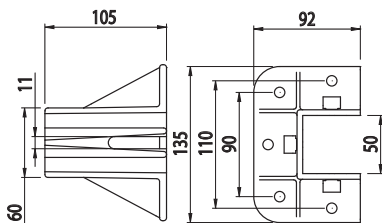
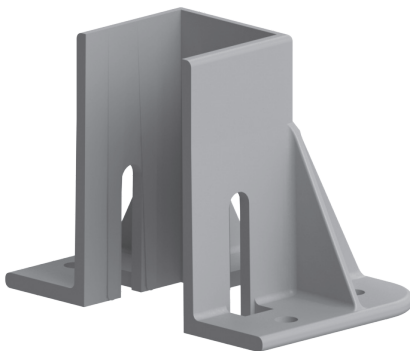

Cod	Note	g
084.409.013	50x50 mm	344

Sandblasted aluminium

Alluminio sabbato
Aluminio arenado
Aluminium sablé
Sandgestrahltes Aluminium

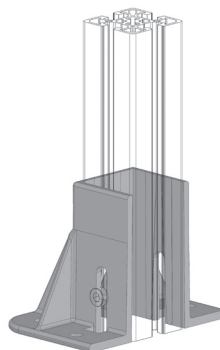



FLOOR MOUNT BASE

BASE A PAVIMENTO
BASE DE ANCLAJE
EMBASE DE FIXATION
PFOSTENKONSOLE

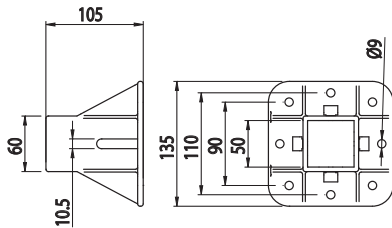
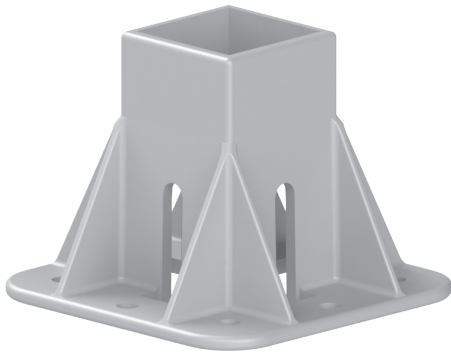

Cod	Note	g
084.409.009	50x50 mm	580

Sandblasted aluminium

Alluminio sabbato
Aluminio arenado
Aluminium sablé
Sandgestrahltes Aluminium

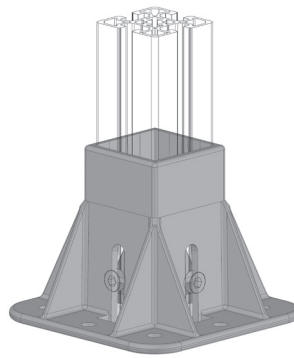

FLOOR MOUNT BASE

BASE A PAVIMENTO
BASE DE ANCLAJE
EMBASE DE FIXATION
PFOSTENKONSOLE

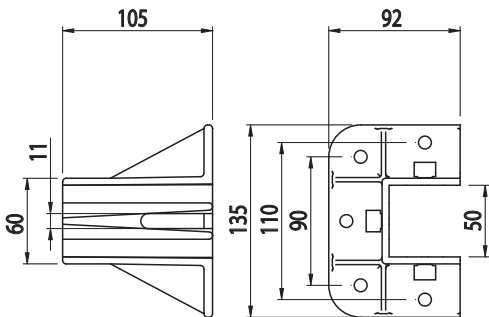
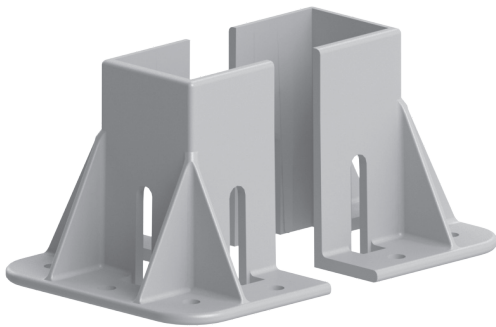

Cod	Note	g
084.409.010	50x100 mm	688

Sandblasted aluminium

Alluminio sabbato
Aluminio arenado
Aluminium sablé
Sandgestrahltes Aluminium

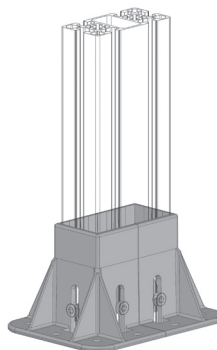

**FLOOR MOUNT BASE**

BASE A PAVIMENTO
BASE DE ANCLAJE
EMBASE DE FIXATION
PFOSTENKONSOLE

BH
105
50

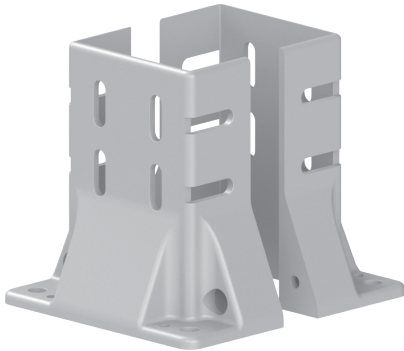

Cod	Note	g
084.409.012	100x100 mm	1500

Sandblasted aluminium

Alluminio sabbato
Aluminio arenado
Aluminium sablé
Sandgestrahltes Aluminium

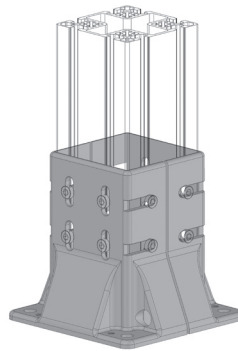
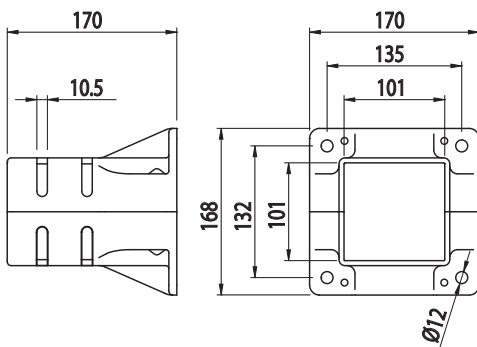
**CAP FOR PILLAR, 45X45**

TAPPO PER PIANTONE 45X45
TAPÓN PARA COLUMNA 45X45
CHAPEAU POUR COLONNE 45X45
ABDECKKAPPE FÜR PFOSTEN 45X45

Cod	Note	g
084.207.004	For 45x45 mm square profiles - Per profili 45x45 mm quadrati - Para perfiles de 45x45 mm cuadrados - Pour profilés 45x45 carrés - Für Profile 45x45 mm viereckig	20

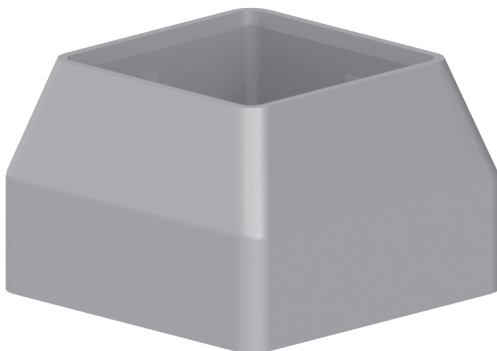
**Grey polyamide**

Poliammide grigio
Poliamida color gris
Polyamide gris
Polyamid grau

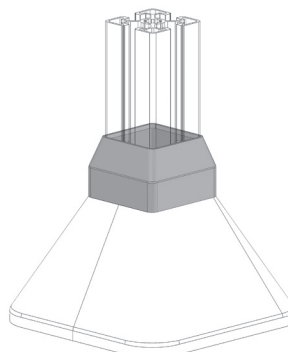
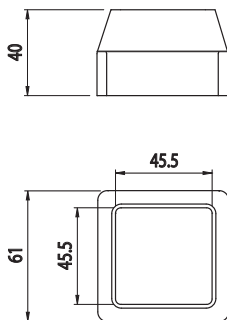



STOP FOR CARRIAGE
FERMO PER CARRELLO
RETÉN PARA CARRO
BUTÉE POUR CHARIOT
FESTSTELLER FÜR WAGEN

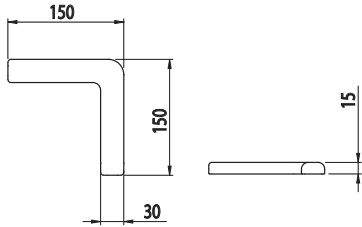
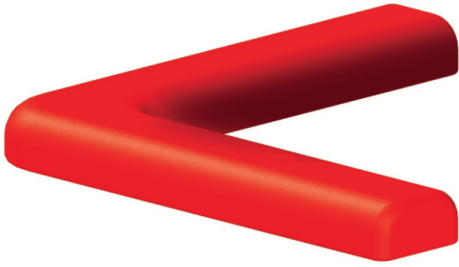

Cod	Note	g
511.011.000R	■	69
511.011.000B	■	69
511.011.000V	■	69
511.011.000G	■	69

Polyamide
Poliammide
Poliamida
Polyamide
Polyamid



**SWIVEL CASTOR**

RUOTA GIREVOLE
RUEDA GIRATORIA
ROULETTE PIVOTANTE
LENKROLLE

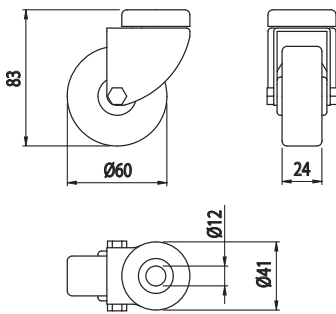

Cod	Note	g
084.404.001	Central screw fastening - Fissaggio a vite centrale - Fijación con tornillo central - Fixation à vis centrale - Befestigung mittels mittlerer Schraube	228

Rubber wheel

Ruota in gomma
Rueda de goma
Roue en caoutchouc
Rad aus Gummi
50Kg

Chromed steel bracket

Supporto in acciaio cromato
Soporte de acero cromado
Support en acier chromé
Halterung aus verchromtem Stahl

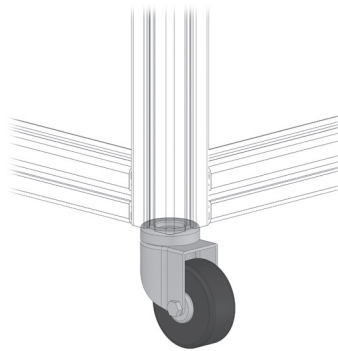
**SWIVEL CASTOR**

RUOTA GIREVOLE
RUEDA GIRATORIA
ROULETTE PIVOTANTE
LENKROLLE

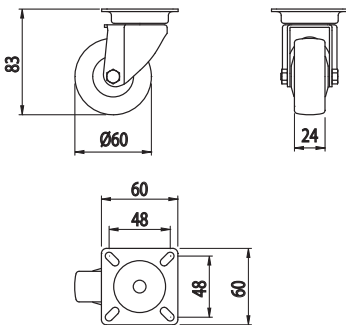

Cod	Note	g
084.404.006	Flange fastening - Fissaggio a flangia - Fijación con brida - Fixation à bride - Befestigung mittels Flansch	330

Rubber wheel

Ruota in gomma
Rueda de goma
Roue en caoutchouc
Rad aus Gummi
50Kg

Chromed steel bracket

Supporto in acciaio cromato
Soporte de acero cromado
Support en acier chromé
Halterung aus verchromtem Stahl

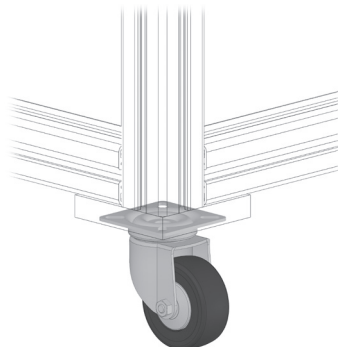



SWIVEL CASTOR WITH BRAKE

RUOTA GIREVOLE CON FRENO
RUEDA GIRATORIA CON FRENO
ROULETTE PIVOTANTE AVEC FREIN
LENKROLLE MIT FESTSTELLER

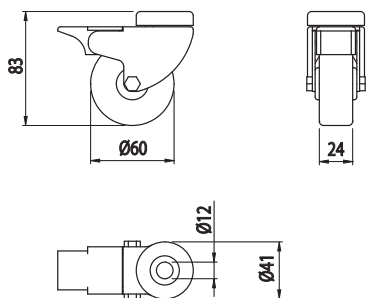

Cod	Note	g
084.404.003	Central screw fastening and brake - Fissaggio a vite centrale e freno - Fijación con tornillo central y freno - Fixation à vis centrale et frein - Befestigung mittels mittlerer Schraube und Bremse	330

Rubber wheel

Ruota in gomma
Rueda de goma
Roue en caoutchouc
Rad aus Gummi

50Kg

Chromed steel bracket

Supporto in acciaio cromato
Soporte de acero cromado
Support en acier chromé
Halterung aus verchromtem Stahl

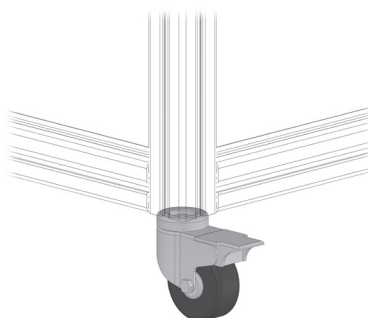

SWIVEL CASTOR WITH BRAKE

RUOTA GIREVOLE CON FRENO
RUEDA GIRATORIA CON FRENO
ROULETTE PIVOTANTE AVEC FREIN
LENKROLLE MIT FESTSTELLER

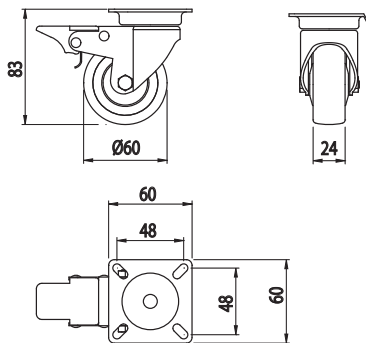

Cod	Note	g
084.404.008	Flange fastening and brake - Fissaggio a flangia e freno - Fijación con brida y freno - Fixation à bride et frein - Befestigung mittels Flansch und Bremse	400

Rubber wheel

Ruota in gomma
Rueda de goma
Roue en caoutchouc
Rad aus Gummi

50Kg

Chromed steel bracket

Supporto in acciaio cromato
Soporte de acero cromado
Support en acier chromé
Halterung aus verchromtem Stahl

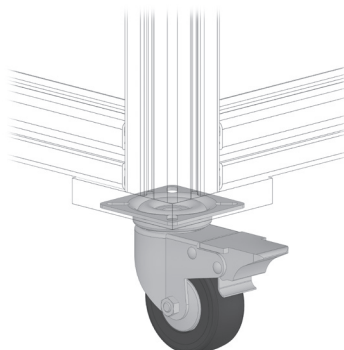

**SWIVEL CASTOR**

RUOTA GIREVOLE
RUEDA GIRATORIA
ROULETTE PIVOTANTE
LENKROLLE

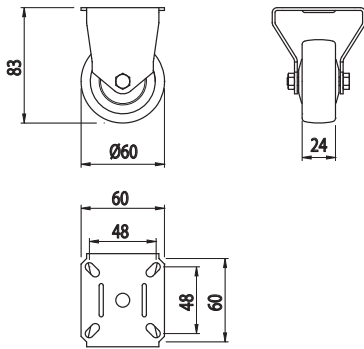
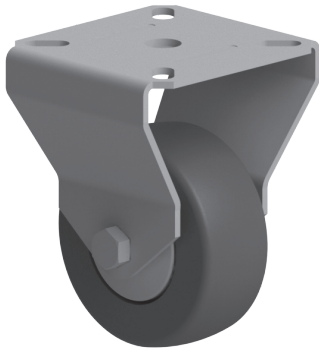

Cod	Note	g
084.404.007	Flange fastening - Fissaggio a flangia - Fijación con brida - Fixation à bride - Befestigung mittels Flansch	260

Rubber wheel

Ruota in gomma
Rueda de goma
Roue en caoutchouc
Rad aus Gummi
50Kg

Chromed steel bracket

Supporto in acciaio cromato
Soporte de acero cromado
Support en acier chromé
Halterung aus verchromtem Stahl

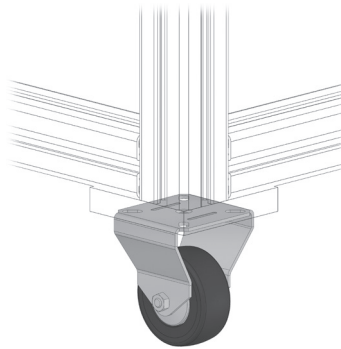



SWIVEL CASTOR

RUOTA GIREVOLE
RUEDA GIRATORIA
ROULETTE PIVOTANTE
LENKROLLE

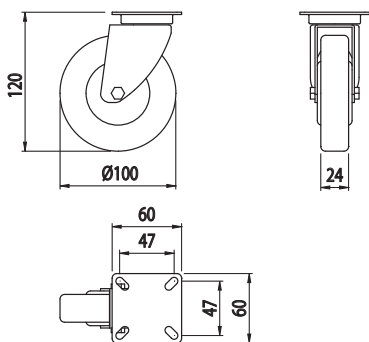

Cod	Note	g
084.404.002	Flange fastening - Fissaggio a flangia - Fijación con brida - Fixation à bride - Befestigung mittels Flansch	427

Rubber wheel

Ruota in gomma
Rueda de goma
Roue en caoutchouc
Rad aus Gummi
55Kg

Chromed steel bracket

Supporto in acciaio cromato
Soporte de acero cromado
Support en acier chromé
Halterung aus verchromtem Stahl

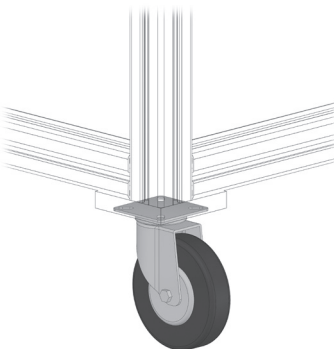

SWIVEL CASTOR WITH BRAKE

RUOTA GIREVOLE CON FRENO
RUEDA GIRATORIA CON FRENO
ROULETTE PIVOTANTE AVEC FREIN
LENKROLLE MIT FESTSTELLER

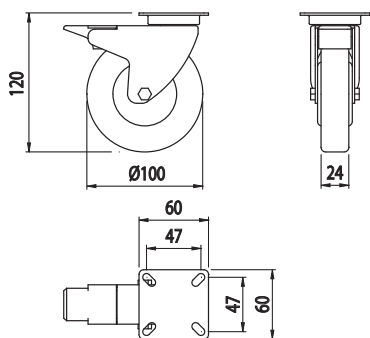

Cod	Note	g
084.404.004	Flange fastening and brake - Fissaggio a flangia e freno - Fijación con brida y freno - Fixation à bride et frein - Befestigung mittels Flansch und Bremse	487

Rubber wheel

Ruota in gomma
Rueda de goma
Roue en caoutchouc
Rad aus Gummi
55Kg

Chromed steel bracket

Supporto in acciaio cromato
Soporte de acero cromado
Support en acier chromé
Halterung aus verchromtem Stahl

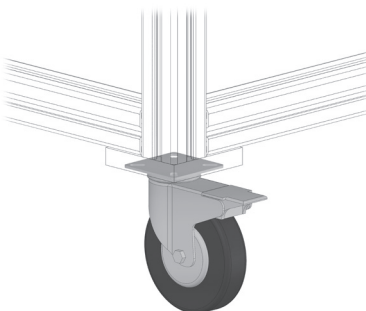

**SWIVEL CASTOR**

RUOTA GIREVOLE
RUEDA GIRATORIA
ROULETTE PIVOTANTE
LENKROLLE

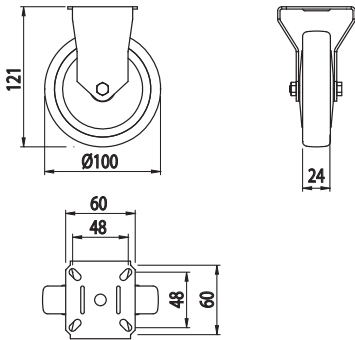
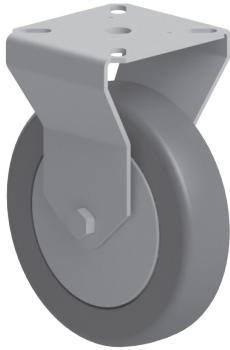

Cod	Note	g
084.404.009	Flange fastening - Fissaggio a flangia - Fijación con brida - Fixation à bride - Befestigung mittels Flansch	400

Rubber wheel

Ruota in gomma
Rueda de goma
Roue en caoutchouc
Rad aus Gummi
55Kg

Chromed steel bracket

Supporto in acciaio cromato
Soporte de acero cromado
Support en acier chromé
Halterung aus verchromtem Stahl

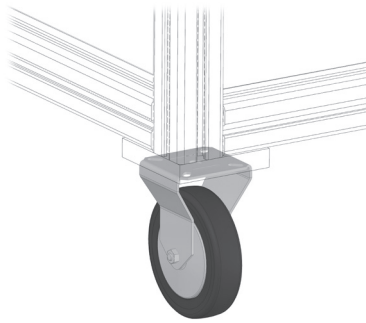
**SWIVEL CASTOR WITH BRAKE**

RUOTA GIREVOLE CON FRENO
RUEDA GIRATORIA CON FRENO
ROULETTE PIVOTANTE AVEC FREIN
LENKROLLE MIT FESTSTELLER

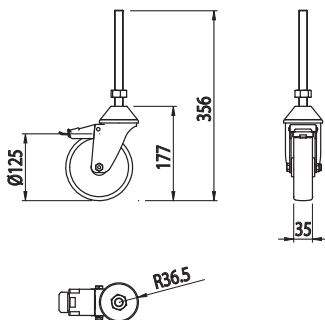

Cod	Note	g
084.404.005	Fastening with M16 pin and brake - Fissaggio con perno M16 e freno - Fijación con perno M16 y freno - Fixation avec pivot M16 et frein - Befestigung mit Bolzen M16 und Bremse	1500

Rubber wheel

Ruota in gomma
Rueda de goma
Roue en caoutchouc
Rad aus Gummi
180Kg

Stainless steel bracket

Supporto in acciaio inox
Soporte de acero inoxidable
Support en acier chromé
Halterung aus rostfreiem Stahl

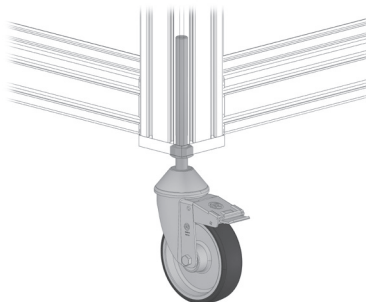



PANEL FASTENING WITH SAFETY

FISSAGGIO PANNELLI CON SICUREZZA
FIJACIÓN PANELES CON SEGURIDAD
FIXATION PANNEAUX AVEC SÉCURITÉ
PLATTENBEFESTIG. MIT SICHERHEITSEINRICHTUNG

PATENT

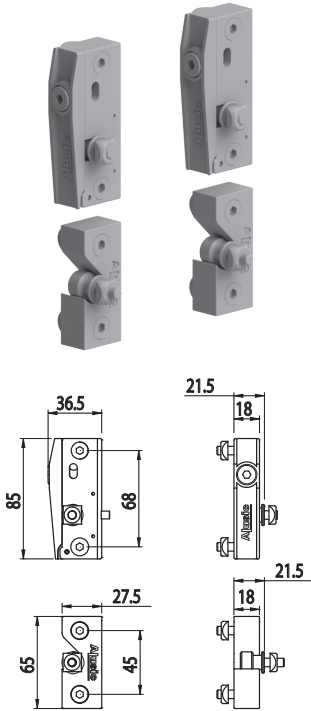

Cod	Note	g
084.407.003	Kit with quick release fastener and safety ejector - Kit con chiusura rapida ed espulsori di sicurezza - Kit con cierre rápido y expulsores de seguridad - Kit à fermeture rapide et dispositifs d'expulsion de sécurité - Kit mit Schnellverschluss und Sicherheitsauswerfern	331

Grey polyamide
Poliammide grigio
Poliamida color gris
Polyamide gris
Polyamid grau

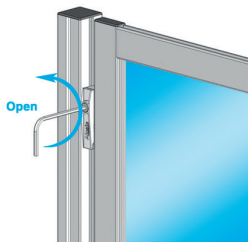
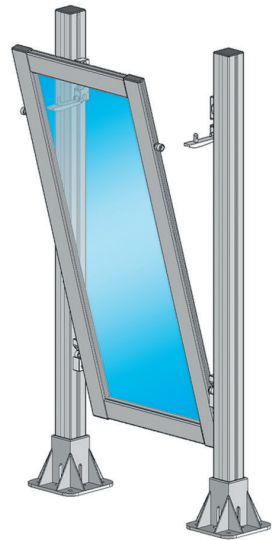
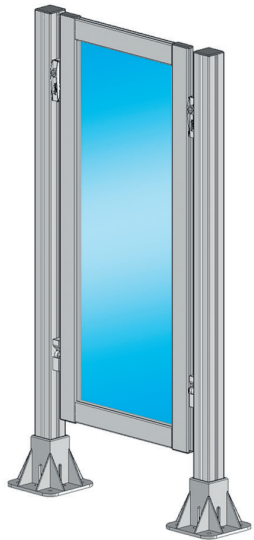

APERTURA: RUOTARE IN SENSO ANTIORARIO
OPENING: ROTATE COUNTERCLOCKWISE
APERTURA: GIRAR EN EL SENTIDO ANTIHORARIO
OUVERTURE: TOURNER DANS LE SENS ANTI-HORAIRE
ÖFFNUNG: DREHUNG ENTGEGEN DEM UHRZEIGERSINN

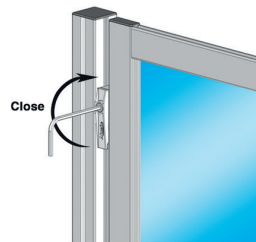

CHIUSURA: RUOTARE IN SENSO ORARIO
CLOSING: ROTATE CLOCKWISE
CIERRE: GIRAR EN EL SENTIDO HORARIO
FERMETURE: TOURNER DANS LE SENS HORAIRE
VERSCHLUSS: DREHUNG IM UHRZEIGERSINN

**QUICK PANEL FASTENER**

FISSAGGIO PANNELLI RAPIDO
 FIJACIÓN DE PANELES RÁPIDO
 FIXATION RAPIDE PANNEAUX
 SCHNELLBEFESTIGUNG PLATTEN

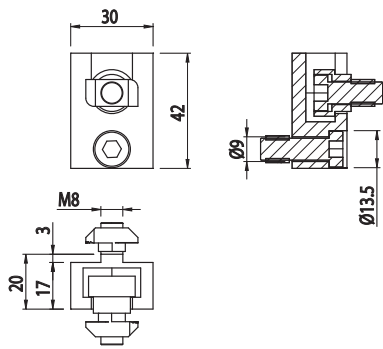
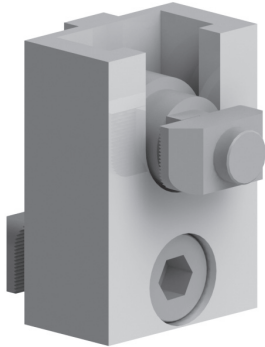

Cod	Note	g
084.407.010	Complete with bushing - Completo di boccia - Incluye casquillo - Doté de douille - Einschließlich Buchse	47

Anodised aluminium

Alluminio anodizzato
 Aluminio anodizado
 Aluminium anodisé
 Eloxiertes Aluminium

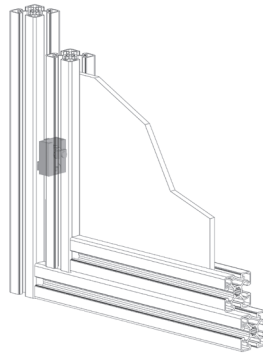



ADJUSTABLE FASTENER BLOCK

BLOCCHETTO DI FISSAGGIO REGOLABILE
BLOQUE DE FIJACIÓN REGULABLE
BLOC DE FIXATION RÉGLABLE
EINSTELLBARER BEFESTIGUNGSBLOCK

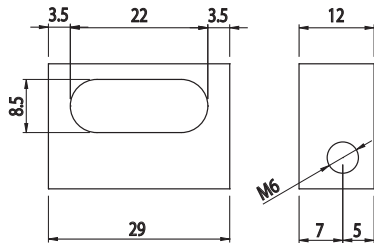

Cod	Note	g
084.507.001	Panel thickness 1-8 mm - Spessore pannelli 1-8 mm - Grosor de los paneles 1-8 mm - Épaisseur panneaux 1-8 mm - Plattendicke 1-8 mm	10

Sandblasted aluminium

Alluminio sabbiato
Aluminio arenado
Aluminium sablé
Sandgestrahltes Aluminium

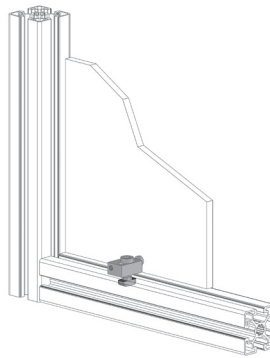

GLASS RETENTION BLOCK

BLOCCHETTO FERMAVETRO
BLOQUE SUJETA-CRISTAL
BLOC DE FIXATION VERRE
SCHEIBENSTOPPERBLOCK

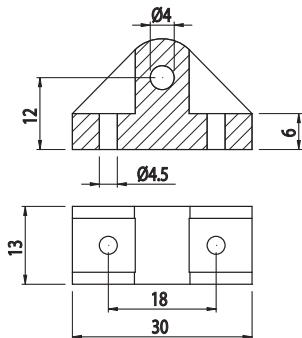
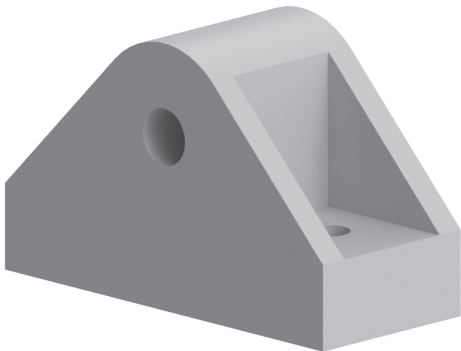

Cod	Note	g
084.509.001	Panel thickness 1-8 mm - Spessore pannelli 1-8 mm - Grosor de los paneles 1-8 mm - Épaisseur panneaux 1-8 mm - Plattendicke 1-8 mm	4

Grey polyamide

Poliammide grigio
Poliamida color gris
Polyamide gris
Polyamid grau

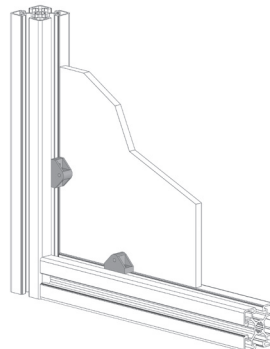

**GLASS RETENTION WASHER**

RONDELLA FERMAVETRO
 ARANDELA SUJETA-CRISTAL
 RONDELLE DE FIXATION VERRE
 SCHEIBENSTOPPERRING

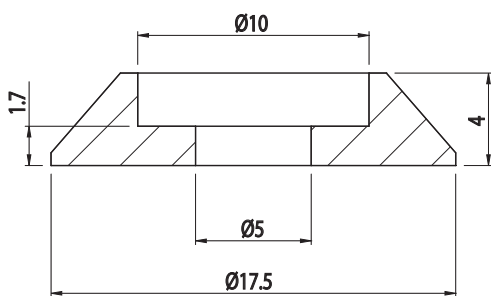

Cod	Note	g
084.509.002	For 084.509.001 - Per 084.509.001 - Para 084.509.001 - Pour 084.509.001 - Für 084.509.001	1

Grey polyamide

Poliammide grigio
 Poliamida color gris
 Polyamide gris
 Polyamid grau

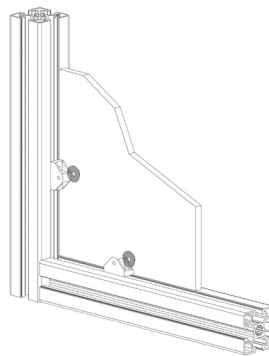
**GLASS PANEL CLAMP**

MORSETTO PANNELLO IN VETRO
 MORDAZA PANEL DE VIDRIO
 PINCE DE FIXATION PANNEAU EN VERRE
 KLEMME FÜR GLASSCHEIBE

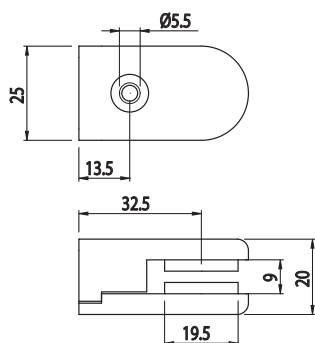

Cod	Note	g
084.509.003	Panel thickness 2-10 mm - Spessore pannelli 2-10 mm - Grosor de los paneles 2-10 mm - Épaisseur panneaux 2-10 mm - Plattendicke 2-10 mm	74

Zamak

Zama
 Zamak
 Zamak
 Zamak

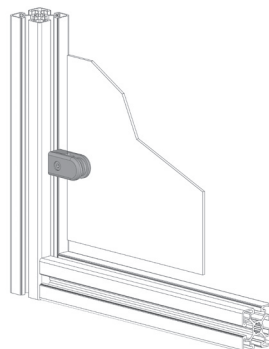



FASTENER BLOCK
BLOCCHETTO DI FISSAGGIO
BLOQUE DE FIJACIÓN
BLOC DE FIXATION
BEFESTIGUNGSBLOCK

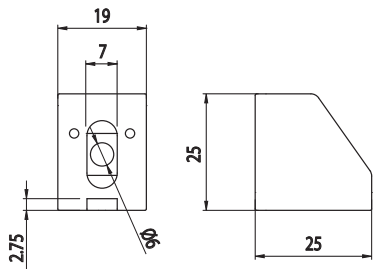
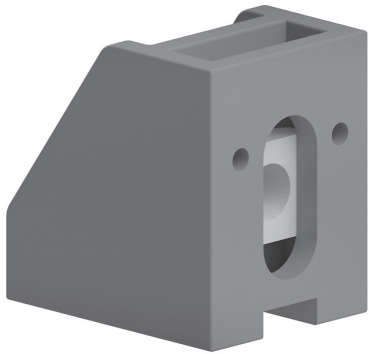

Cod	Note	g
084.510.001	Panel thickness 1-8 mm - Spessore pannelli 1-8 mm - Grosor de los paneles 1-8 mm - Épaisseur panneaux 1-8 mm - Plattendicke 1-8 mm	10

Black polyamide
Poliammide nero
Poliamida color negro
Polyamide noir
Polyamid schwarz

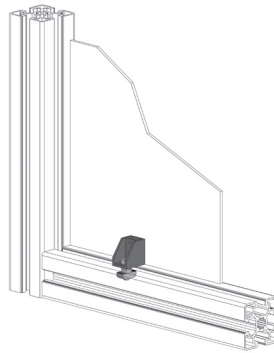

SPACER FOR 084.510.001
Distanziale per 084.510.001
Distanciador para 084.510.001
Entretoise pour 084.510.001
Distanzstück für 084.510.001

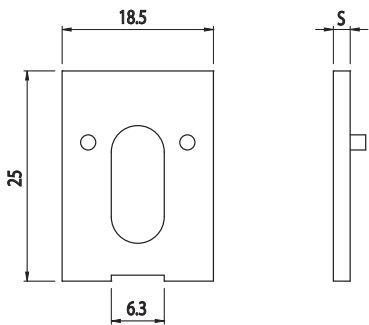

Cod	Note	g
084.510.002	2 mm	1
084.510.003	3 mm	1
084.510.004	5 mm	2

Black polyamide
Poliammide nero
Poliamida color negro
Polyamide noir
Polyamid schwarz

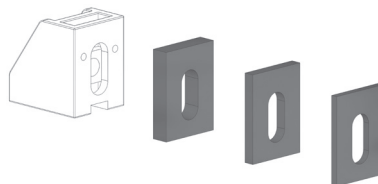



FASTENER BLOCK
 BLOCCHETTO DI FISSAGGIO
 BLOQUE DE FIJACIÓN
 BLOC DE FIXATION
 BEFESTIGUNGSBLOCK

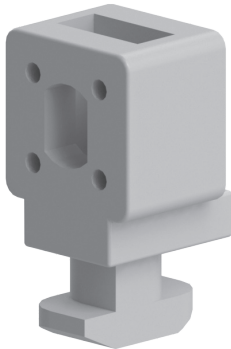

Cod	Note	g
084.510.009	Complete with M6 nut - Completo di dado M6 - Incluye tuerca M6 - Doté d'écrou M6 - Einschließlich Mutter M6	10

Grey polyamide
 Poliammide grigio
 Poliamida color gris
 Polyamide gris
 Polyamid grau

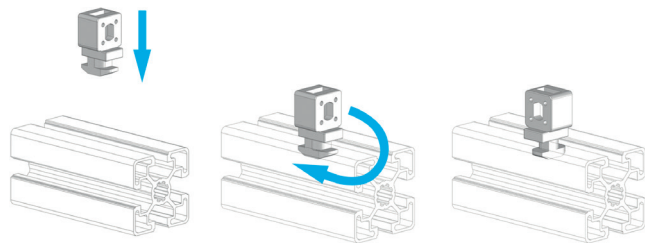
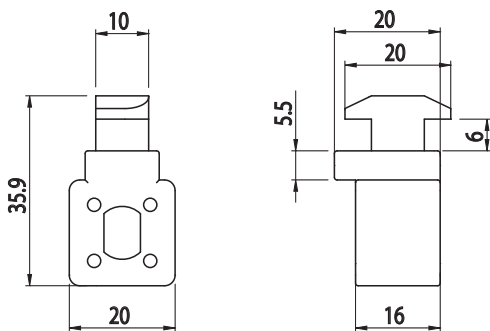

SPACER FOR 084.510.006 AND 084.510.007
 DISTANZIALE PER 084.510.006 E 084.510.007
 DISTANCIADOR PARA 084.510.006 Y 084.510.007
 ENTRETOISE POUR 084.510.006 ET 084.510.007
 DISTANZSTÜCK FÜR 084.510.006 UND 084.510.007

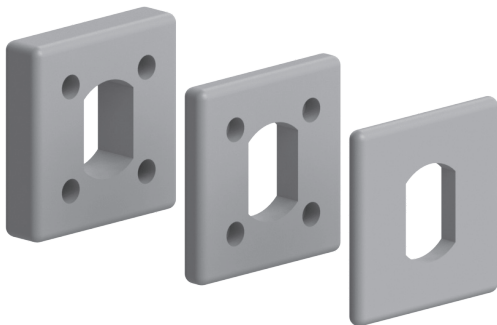

Cod	Note	g
084.510.010	2 mm	1
084.510.011	3 mm	1
084.510.012	5 mm	2

Grey polyamide
 Poliammide grigio
 Poliamida color gris
 Polyamide gris
 Polyamid grau

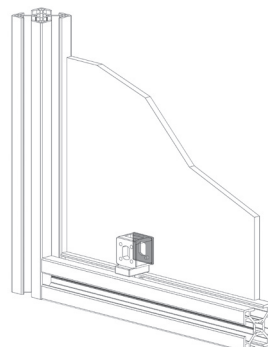
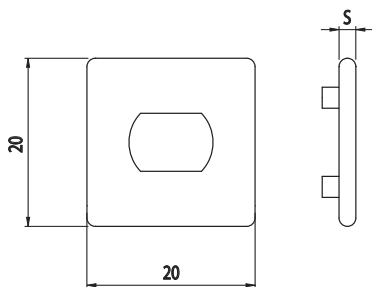



FASTENER BLOCK
BLOCCHETTO DI FISSAGGIO
BLOQUE DE FIJACIÓN
BLOC DE FIXATION
BEFESTIGUNGSBLOCK

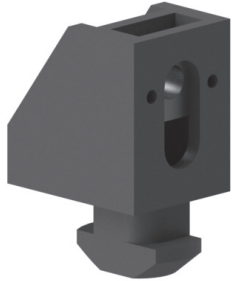

Cod	Note	g
084.510.017	M6 nut included - Completo di dado M6 - Tuerca M6 incluida - Écrou M6 inclus - Nutenstein M6 im Lieferumfang enthalten	11

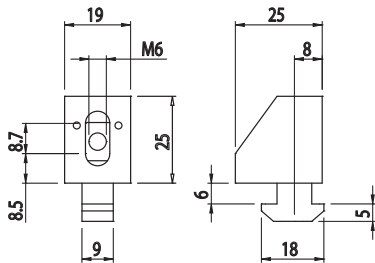

Black polyamide
Poliammide nero
Poliamida color negro
Polyamide noir
Polyamid schwarz

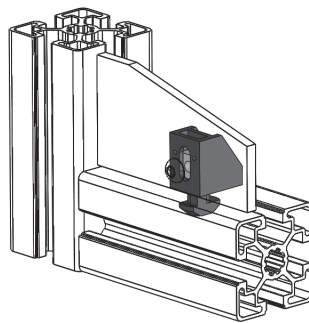

FASTENER BLOCK
BLOCCHETTO DI FISSAGGIO
BLOQUE DE FIJACIÓN
BLOC DE FIXATION
BEFESTIGUNGSBLOCK



Cod	Note	g
084.510.020	Interlock fastening - Fissaggio a scatto - Fijación por encastre - Fixation par emboîtement - Klemmbefestigung	10

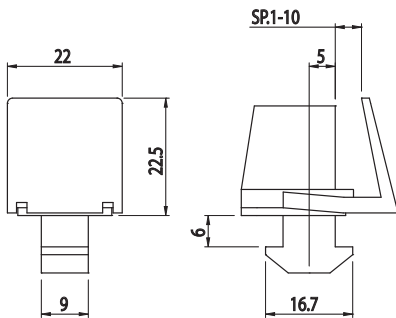

Black polyamide
Poliammide nero
Poliamida color negro
Polyamide noir
Polyamid schwarz

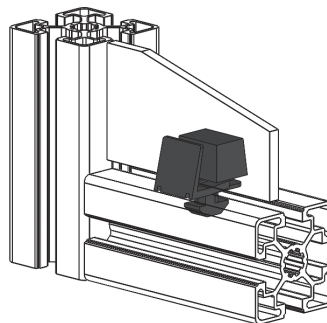



FASTENER BLOCK
 BLOCCHETTO DI FISSAGGIO
 BLOQUE DE FIJACIÓN
 BLOC DE FIXATION
 BEFESTIGUNGSBLOCK

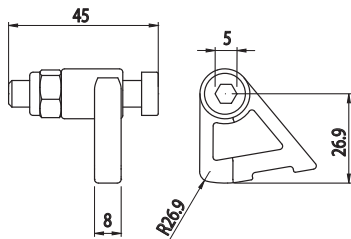

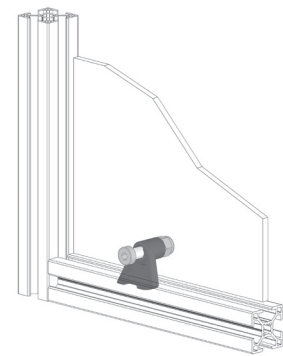
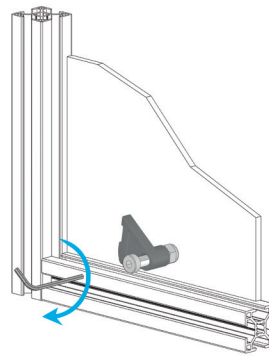

Cod	Note	g
084.519.003	For RH removable panels - Per pannelli estraibili destra - Para paneles extraíbles derecha - Pour panneaux extractibles droite - Für herausziehbare Platten rechts	33

Grey polyamide
 Poliammide grigio
 Poliamida color gris
 Polyamide gris
 Polyamid grau

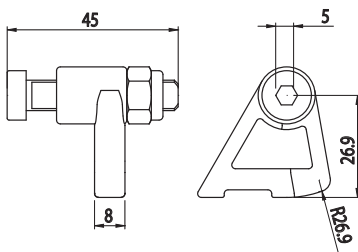

FASTENER BLOCK
 BLOCCHETTO DI FISSAGGIO
 BLOQUE DE FIJACIÓN
 BLOC DE FIXATION
 BEFESTIGUNGSBLOCK

Cod	Note	g
084.519.004	For LH removable panels - Per pannelli estraibili sinistra - Para paneles extraíbles izquierda - Pour panneaux extractibles gauche - Für herausziehbare Platten links	33

Grey polyamide
 Poliammide grigio
 Poliamida color gris
 Polyamide gris
 Polyamid grau



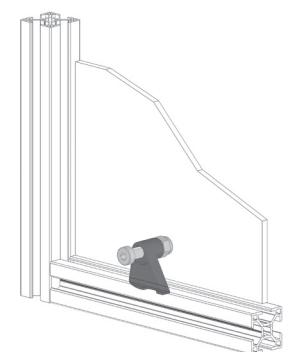
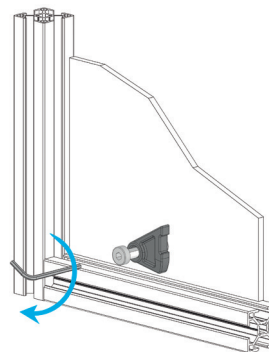

MULTI-USE

MULTIUSO
MULTIUSO
MULTIFONCTION
MEHRZWECKELEMENT

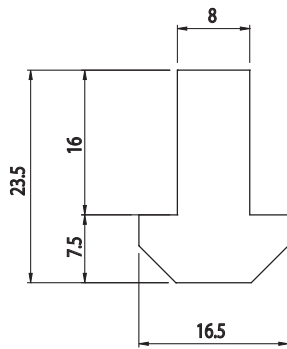
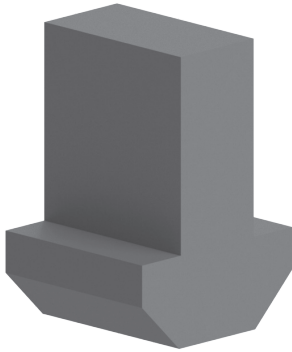

Cod	Note	g/m
084.514.013	L = 2 m	258

Polietilene nero

Polietilene nero
Polietileno color negro
Polyéthylène noir
Polyethylen schwarz

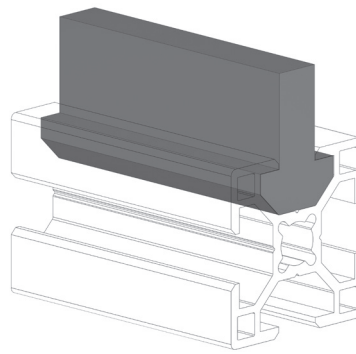

MULTI-USE

MULTIUSO
MULTIUSO
MULTIFONCTION
MEHRZWECKELEMENT

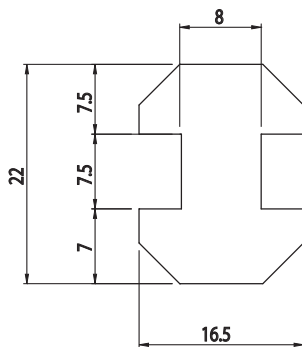
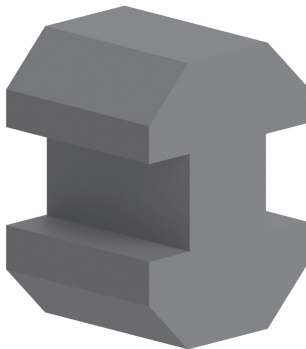

Cod	Note	g/m
084.514.014	L = 2 m	293

Polietilene nero

Polietilene nero
Polietileno color negro
Polyéthylène noir
Polyethylen schwarz

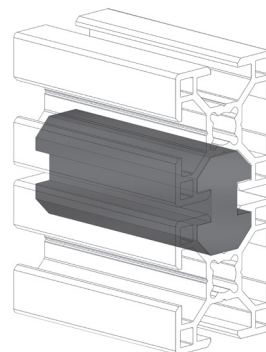

**MULTI-USE**

MULTIUSO
MULTIUSO
MULTIFONCTION
MEHRZWECKELEMENT

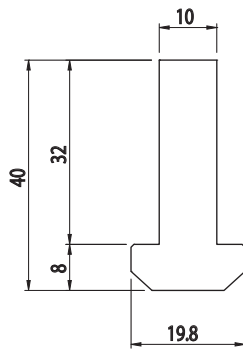
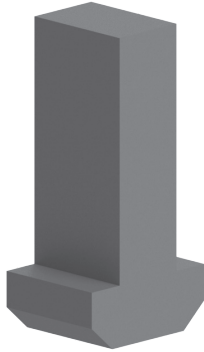

Cod	Note	g/m
084.514.012	L = 2 m	750

**Polietilene nero**

Polietilene nero
Polietileno color negro
Polyéthylène noir
Polyethylen schwarz

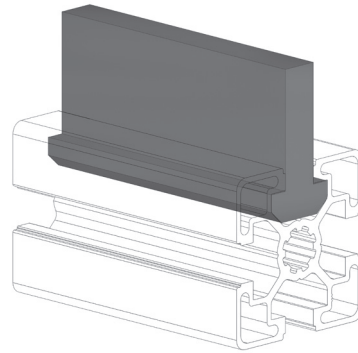
**MULTI-USE**

MULTIUSO
MULTIUSO
MULTIFONCTION
MEHRZWECKELEMENT

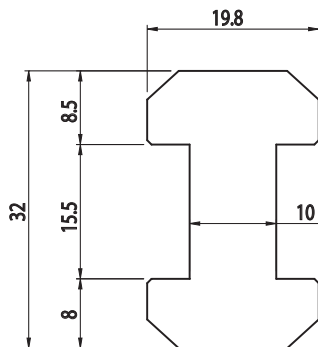
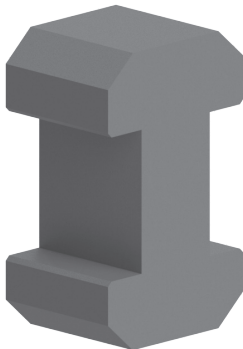

Cod	Note	g/m
084.514.016	L = 2 m	503

**Polietilene nero**

Polietilene nero
Polietileno color negro
Polyéthylène noir
Polyethylen schwarz

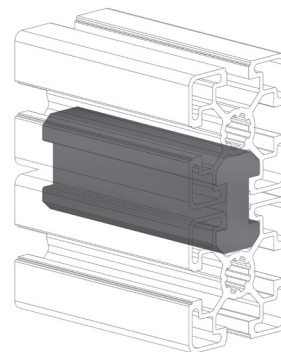



PANEL GASKET

GUARNIZIONE PER PANNELLO
JUNTA PARA PANEL
JOINT POUR PANNEAU
SCHEIBENDICHTUNG

BH
65
20

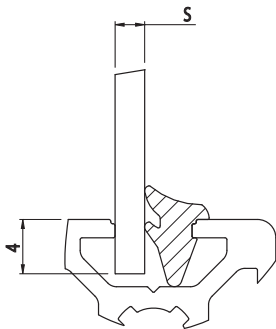
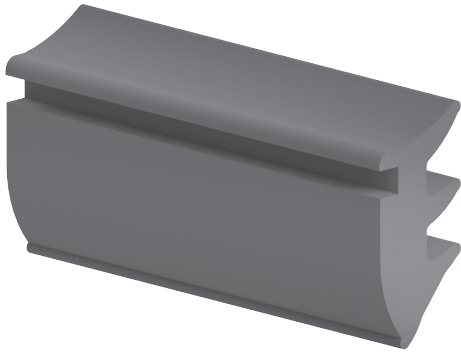

Cod	S	Col		g/m
084.512.003	2	■	200 m	50

Thermoplastic rubber

Gomma termoplastica
Goma termoplástica
Caoutchouc thermoplastique
Thermoplastischer Gummi

PANEL GASKET

GUARNIZIONE PER PANNELLO
JUNTA PARA PANEL
JOINT POUR PANNEAU
SCHEIBENDICHTUNG

BH
85
30

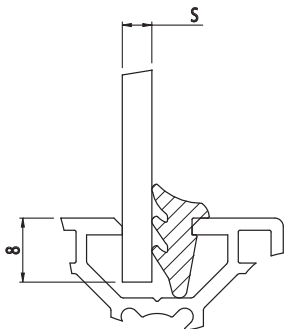
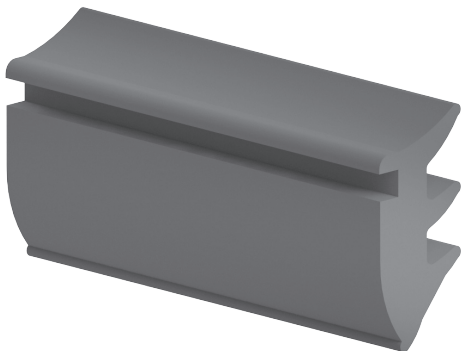

Cod	S	Col		g/m
084.512.006	1	■	90 m	106
5004A/3170	2	■	120 m	100
084.512.004	3	■	150 m	64
084.512.003	4	■	200 m	50
084.512.056	5	■	125 m	34
084.512.056G	5	■	125 m	34
084.512.006G	1	■	90 m	106

Thermoplastic rubber

Gomma termoplastica
Goma termoplástica
Caoutchouc thermoplastique
Thermoplastischer Gummi

**PANEL GASKET**

GUARNIZIONE PER PANNELLO
JUNTA PARA PANEL
JOINT POUR PANNEAU
SCHEIBENDICHTUNG

BH 105 50 BH 105 45 BH 105 40

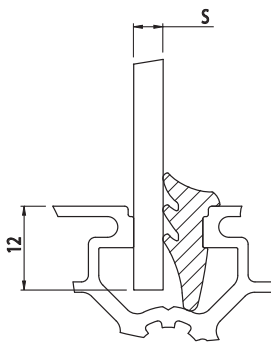
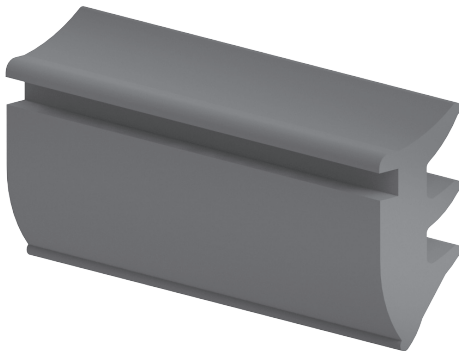

Cod	S	Col		g/m
084.512.030	5	■	90 m	50
084.512.030G	5	■	90 m	50

Thermoplastic rubber

Gomma termoplastica
Goma termoplástica
Caoutchouc thermoplastique
Thermoplastischer Gummi

RIGID SLOT CLOSURE

CHIUDICAVA RIGIDO
TAPA-RANURA RÍGIDO
FERMETURE RAINURE RIGIDE
STARRES VERSCHLIESSELEMENT FÜR NUTEN

BH 85 30

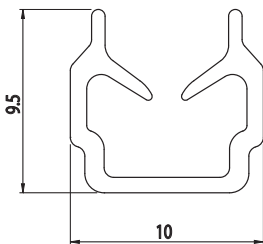
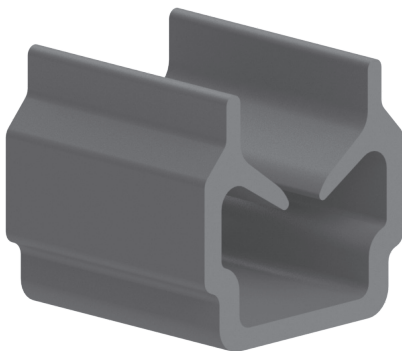

Cod	Note	g/m
084.203.024	Panel thickness: 2-4 mm - Spessore pannelli: 2-4 mm - Grosor de los paneles: 2-4 mm - Épaisseur panneaux: 2-4 mm - Plattendicke: 2-4 mm	40

Rigid black PVC

PVC rigido nero
PVC rígido color negro
PVC rigide noir
Hart-PVC schwarz
L=2000m

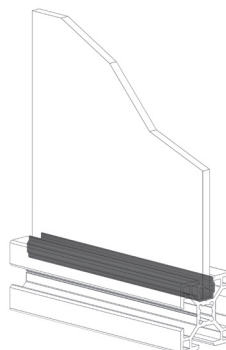



INTERLOCKING SEAL

GUARNIZIONE AD INCASTRO
JUNTA POR ENCAJE
JOINT À ENCASTREMENT
STECKDICHTUNG

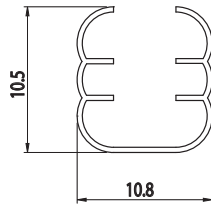
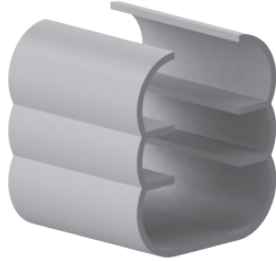

Cod	Note	g/m
084.512.010	Panel thickness: 3-6 mm - Spessore pannelli: 3-6 mm - Grosor de los paneles: 3-6 mm - Épaisseur panneaux: 3-6 mm - Plattendicke: 3-6 mm	45

Rigid and soft grey PVC

PVC rígido e morbido grigio
PVC rígido y flexible color gris
PVC rigide et souple gris
Hart- und Weich-PVC grau
L=2000m

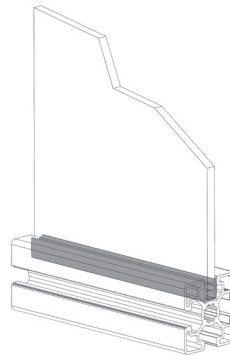

**PET PANEL**

PANNELLO IN PET
PANEL DE PET
PANNEAU EN PET
PLATTE AUS PET

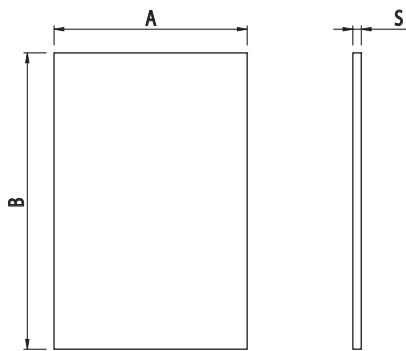

Cod	Color	S	AxB	Kg/m ²
084.538.001	Trasparent	1 mm	2050 x 3050	1,35
084.538.002	Opal	1 mm	2050 x 3050	1,35

Shockproof and Fire classification B-s1, d0

Resistente agli urti e classificato al fuoco in classe B-s1, d0
Resistente a los golpes y con reacción al fuego de clase B-s1, d0
Résistant aux chocs et résistance au feu classée B-s1, d0
Stoßfest und in Baustoffklasse B-s1, d0 eingestuft (Brandverhalten)

POLYCARBONATE PANEL

PANNELLO IN POLICARBONATO
PANEL DE POLICARBONATO
PANNEAU EN POLYCARBONATE
PLATTE AUS POLYCARBONAT

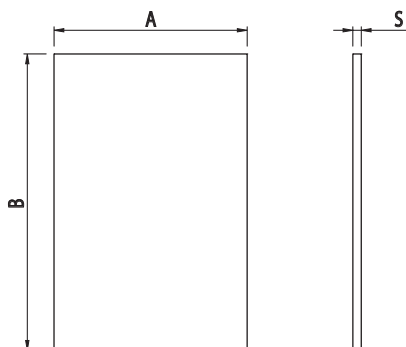

Cod	Color	S	AxB	Kg/m ²
030LEX	Trasparent	3 mm	2050 x 3050	3,6
031LEX	Trasparent	4 mm	2050 x 3050	4,8
032LEX	Trasparent	5 mm	2050 x 3050	6
034LEX	Trasparent	8 mm	2050 x 3050	9,6
035LEX	Trasparent	10 mm	2050 x 3050	12

Shockproof and weather resistant (-40°C/+120°C)

Resistente agli urti ed agli agenti atmosferici (-40°C/+120°C)
Antichoque y resistente a la intemperie (-40°C/+120°C)
Antichoc et résistant aux intempéries (-40°C/+120°C)
Anti-Stoß und witterungsbeständig (-40°C/+120°C)



POLYCARBONATE PANEL
 PANNELLO IN POLICARBONATO
 PANEL DE POLICARBONATO
 PANNEAU EN POLYCARBONATE
 PLATTE AUS POLYCARBONAT

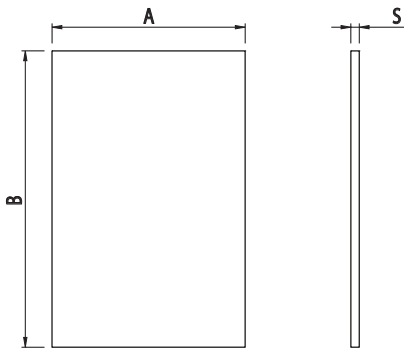

Cod	Color	S	AxB	Kg/m ²
062LEX	Fumé	5 mm	2050 x 3050	6

Shockproof and weather resistant (-40°C/+120°C)

Resistente agli urti ed agli agenti atmosferici (-40°C/+120°C)
 Antichoque y resistente a la intemperie (-40°C/+120°C)
 Antichoc et résistant aux intempéries (-40°C/+120°C)
 Anti-Stoß und witterungsbeständig (-40°C/+120°C)

ALUMINIUM COMPOSITE PANEL
 PANNELLO COMPOSITO IN ALLUMINIO
 PANEL COMPUESTO DE ALUMINIO
 PANNEAU COMPOSITE EN ALUMINIUM
 SANDWICHPANEEL AUS ALUMINIUM

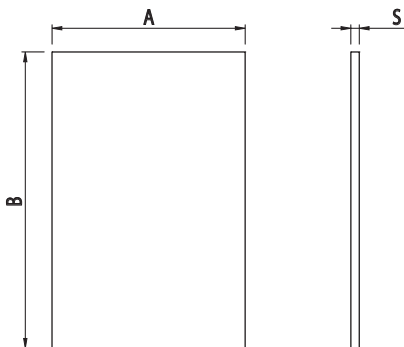

Cod	Color	S	AxB	Kg/m ²
DILITE3	Silver	3 mm	1500 x 4050	3,50

Aluminium and polythene

Alluminio e polietilene
 Aluminio y polietileno
 Aluminium et polyéthylène
 Aluminium und Polyethylen

**PVC FOAMBOARD PANEL**

PANNELLO IN PVC ESPANSO
 PANEL DE PVC EXPANDIDO
 PANNEAU EN PVC EXPANSÉ
 PLATTE AUS PVC-SCHAUM

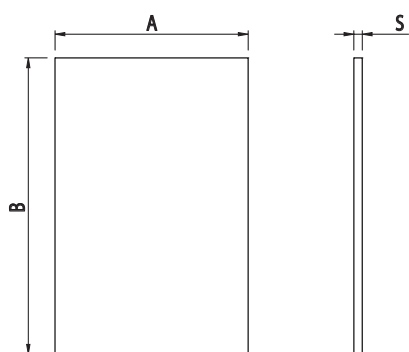

Cod	Color	S	AxB	Kg/m ²
008VEKA103	White	3 mm	2050 x 3050	2,10
008VEKA111	Light blue	3 mm	2050 x 3050	2,10
008VEKA115	Black	3 mm	2050 x 3050	2,10

Shockproof, water- and acid-resistant, self-extinguishing

Resistente agli urti, all'acqua, agli acidi ed autoestingente
 Antichoque, resistente al agua, ácidos y autoextinguible
 Antichoc, résistant à l'eau et aux acides, auto-éxtinguible
 Anti-Stoß, wasserfest, säurebeständig und selbstverlöschend

LAMINATE PANEL

PANNELLO LAMITATO STRATIFICATO
 PANEL LAMINADO ESTRATIFICADO
 PANNEAU LAMINÉ STRATIFIÉ
 LAMINIERTE SCHICHTPLATTE

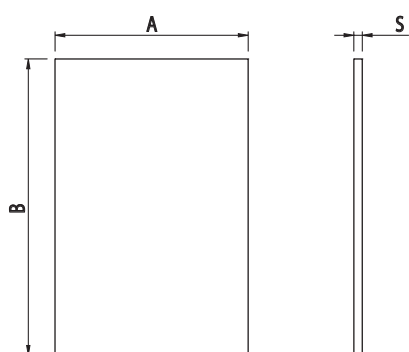

Cod	Color	S	AxB	Kg/m ²
STR3MM	White	3 mm	1300 x 3050	4,50
STR4MM	White	4 mm	1300 x 3050	6
STR5MM	White	5 mm	1300 x 3050	7,50

Shockproof and water resistant

Resistente agli urti ed all'acqua
 Antichoque y resistente al agua
 Antichoc et résistant à l'eau
 Anti-Stoß und wasserfest



ELECTROWELDED MESH

RETE ELETTROSALDATA
MALLA ELECTROSOLDADA
GRILLE ÉLECTROSOUDEE
BAUSTAHLGEWEBE

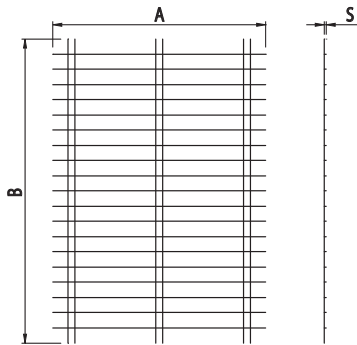
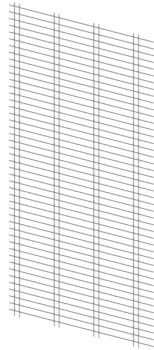

Cod	Color	S	AxB	Kg/m ²
RETE 11x66	Raw	3 mm	1240 x 2400	4
RETE TEC 1003	Yellow RAL 1003	3 mm	1240 x 2400	4
RETE 11x66 INOX	Stainless steel AISI 304	3 mm	1240 x 2400	4

Steel, 15x105x15 (stainless steel or powder coated)

Acciaio 15x105x15 (inox o verniciato a polvere)
Acero 15x105x15 (inoxidable o barnizado con pintura en polvo)
Acier 15x105x15 (inox ou peint à la poudre)
Stahl 15x105x15 (rostfrei oder pulverlackiert)

ELECTROWELDED MESH

RETE ELETTROSALDATA
MALLA ELECTROSOLDADA
GRILLE ÉLECTROSOUDEE
BAUSTAHLGEWEBE

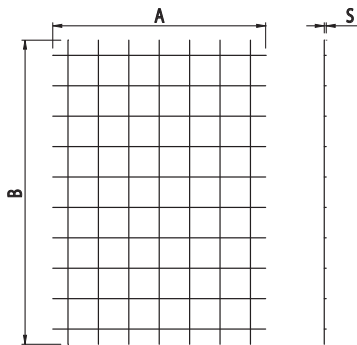
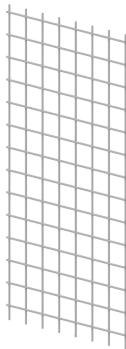

Cod	Color	S	AxB	Kg/m ²
RETE 40X40X4	Raw	4 mm	1600 x 2000	4,50
670.001.000	Black	4 mm	2000 x 1000	4,50

40x40 steel

Acciaio 40x40
Acero 40x40
Acier 40x40
Stahl 40x40

**ALUMINIUM HINGE**

CERNIERA IN ALLUMINIO
BISAGRA DE ALUMINIO
CHARNIÈRE EN ALUMINIUM
ALUMINIUMSCHARNIER

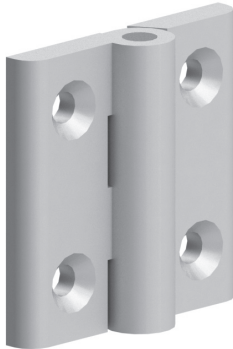
Cod	Note	g
084.503.001	M5x20 UNI 5933 screws not included - Viti TSEI M5x20 non include - Tornillos M5x20 UNI 5933, no incluidos - Vis M5x20 UNI 5933 non fournies - M5x20 UNI5933 Schrauben nicht inklusive	49

Anodised aluminium

Alluminio anodizzato
Aluminio anodizado
Aluminium anodisé
Eloxiertes Aluminium

AISI 303 stainless-steel pin, Ø6 mm

Perno acciaio inox AISI 303 Ø6
Perno de acero inoxidable AISI 303 Ø6
Pivot acier inox AISI 303 Ø 6
Bolzen aus rostfreiem Stahl AISI 303 Ø6

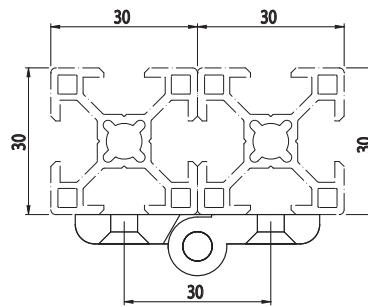
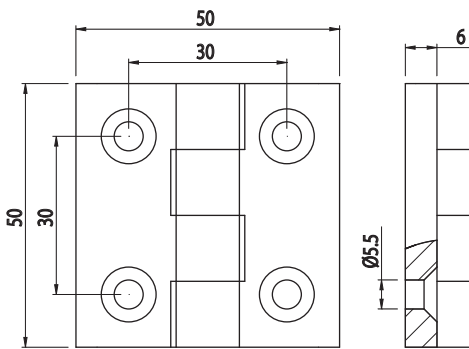
**ALUMINIUM HINGE**

CERNIERA IN ALLUMINIO
BISAGRA DE ALUMINIO
CHARNIÈRE EN ALUMINIUM
ALUMINIUMSCHARNIER

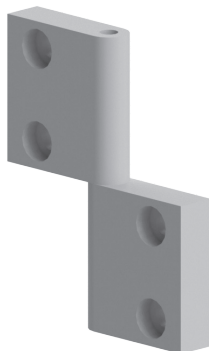
Cod	Note	g
084.502.006	M6x16 DIN 7984 screws not included - Viti M6x16 DIN 7984 non include - Tornillos M6x16 DIN 7984, no incluidos - Vis M6x16 DIN 7984 non fournies - Schrauben M6x16 DIN 7984 nicht inklusive	86

Anodised aluminium

Alluminio anodizzato
Aluminio anodizado
Aluminium anodisé
Eloxiertes Aluminium

AISI 303 stainless-steel pin, Ø5 mm

Perno acciaio inox AISI 303 Ø5
Perno de acero inoxidable AISI 303 Ø5
Pivot acier inox AISI 303 Ø 5
Bolzen aus rostfreiem Stahl AISI 303 Ø5

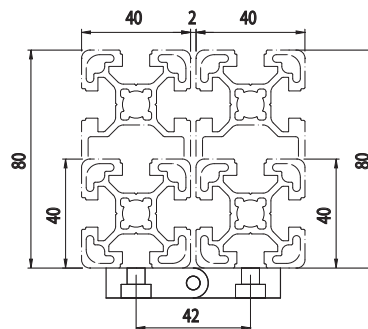
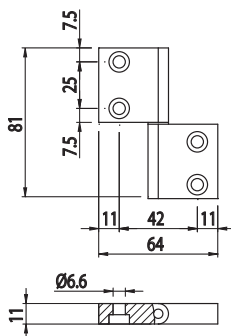



ALUMINIUM HINGE

CERNIERA IN ALLUMINIO
BISAGRA DE ALUMINIO
CHARNIÈRE EN ALUMINIUM
ALUMINIUMSCHARNIER

BH
105
45

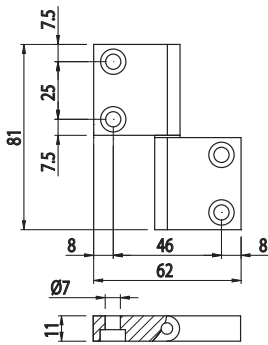
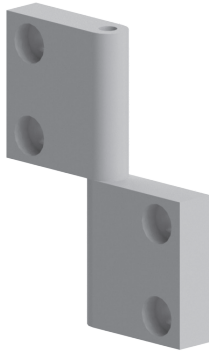

Cod	Note	g
084.502.003	Screws M6x16 DIN 7984 not included - Viti M6x16 DIN 7984 non include - Tornillos M6x16 DIN 7984 no incluidos - Vis M6x16 DIN 7984 non fournies - Schrauben M6x16 DIN 7984 nicht inklusive	86

Anodised aluminium

Alluminio anodizzato
Aluminio anodizado
Aluminium anodisé
Eloxiertes Aluminium

AISI 303 stainless-steel pin, Ø5 mm

Perno acciaio inox AISI 303 Ø5
Perno de acero inoxidable AISI 303 Ø5
Pivot acier inox AISI 303 Ø 5
Bolzen aus rostfreiem Stahl AISI 303 Ø5

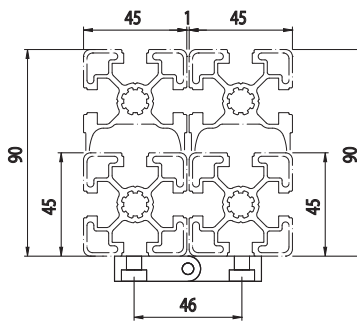

ALUMINIUM HINGE

CERNIERA IN ALLUMINIO
BISAGRA DE ALUMINIO
CHARNIÈRE EN ALUMINIUM
ALUMINIUMSCHARNIER

BH
105
50

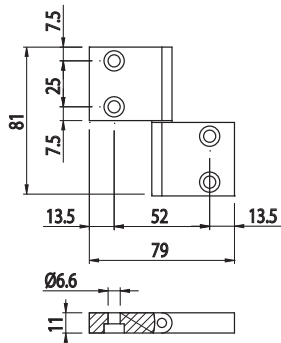
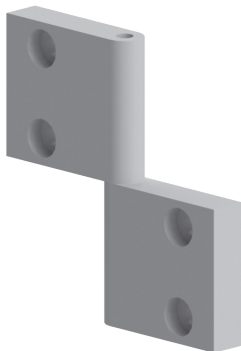

Cod	Note	g
084.502.005	Screws M6x16 DIN 7984 not included - Viti M6x16 DIN 7984 non include - Tornillos M6x16 DIN 7984 no incluidos - Vis M6x16 DIN 7984 non fournies - Schrauben M6x16 DIN 7984 nicht inklusive	86

Anodised aluminium

Alluminio anodizzato
Aluminio anodizado
Aluminium anodisé
Eloxiertes Aluminium

AISI 303 stainless-steel pin, Ø5 mm

Perno acciaio inox AISI 303 Ø5
Perno de acero inoxidable AISI 303 Ø5
Pivot acier inox AISI 303 Ø 5
Bolzen aus rostfreiem Stahl AISI 303 Ø5

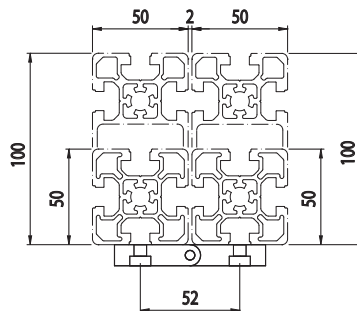

**ALUMINIUM HINGE**

CERNIERA IN ALLUMINIO
BISAGRA DE ALUMINIO
CHARNIÈRE EN ALUMINIUM
ALUMINIUMSCHARNIER

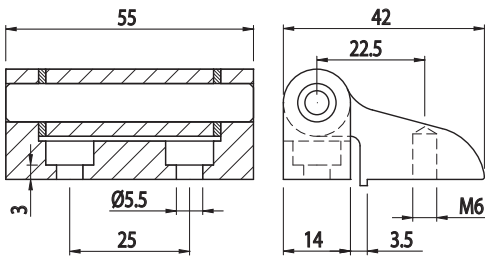
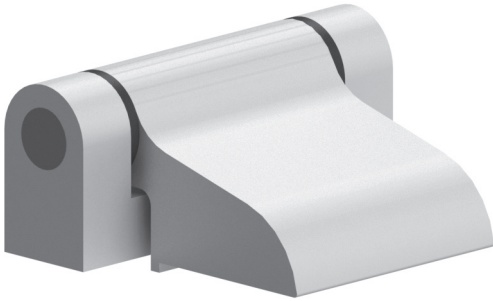

Cod	Note	g
084.503.002	M5x20 DIN 7984 screws not included - Viti M5x20 DIN 7984 non include - Tornillos M5x20 DIN 7984 no incluidos - Vis M5x20 DIN 7984 non fournies - Schrauben M5x20 DIN 7984 nicht inklusive	75

Anodised aluminium

Alluminio anodizzato
Aluminio anodizado
Aluminium anodisé
Eloxiertes Aluminium

AISI 303 stainless-steel pin, Ø8 mm

Perno acciaio inox AISI 303 Ø8
Perno de acero inoxidable AISI 303 Ø8
Pivot acier inox AISI 303 Ø8
Bolzen aus rostfreiem Stahl AISI 303 Ø8

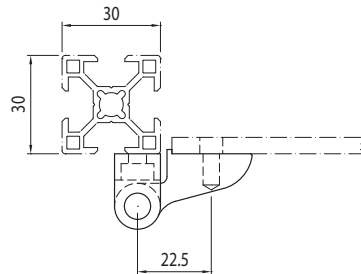
**ALUMINIUM HINGE**

CERNIERA IN ALLUMINIO
BISAGRA DE ALUMINIO
CHARNIÈRE EN ALUMINIUM
ALUMINIUMSCHARNIER

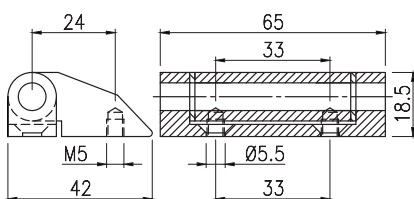
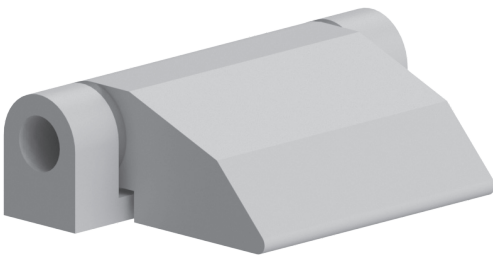

Cod	Note	g
084.503.003	M5x20 UNI 5933 screws not included - Viti M5x20 UNI 5933 non include - Tornillos M5x20 UNI 5933 no incluidos - Vis M5x20 UNI 5933 non fournies - Schrauben M5x20 UNI 5933 nicht inklusive	85

Anodised aluminium

Alluminio anodizzato
Aluminio anodizado
Aluminium anodisé
Eloxiertes Aluminium

AISI 303 stainless-steel pin, Ø8 mm

Perno acciaio inox AISI 303 Ø8
Perno de acero inoxidable AISI 303 Ø8
Pivot acier inox AISI 303 Ø8
Bolzen aus rostfreiem Stahl AISI 303 Ø8

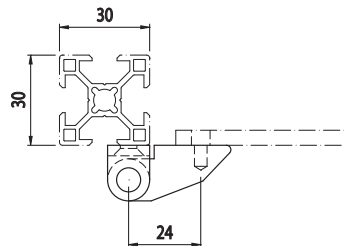



ALUMINIUM HINGE

CERNIERA IN ALLUMINIO
BISAGRA DE ALUMINIO
CHARNIÈRE EN ALUMINIUM
ALUMINIUMSCHARNIER

BH
105
40

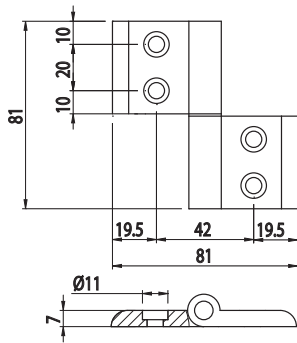

Cod	Note	g
084.500.016	M6x16 DIN 7984 screws not included - Viti M6x16 DIN 7984 non include - Tornillos M6x16 DIN 7984 no incluidos - Vis M6x16 DIN 7984 non fournies - Schrauben M6x16 DIN 7984 nicht inklusive	100

Anodised aluminium

Alluminio anodizzato
Aluminio anodizado
Aluminium anodisé
Eloxiertes Aluminium

AISI 303 stainless-steel pin, Ø8 mm

Perno acciaio inox AISI 303 Ø8
Perno de acero inoxidable AISI 303 Ø8
Pivot acier inox AISI 303 Ø 8
Bolzen aus rostfreiem Stahl AISI 303 Ø8

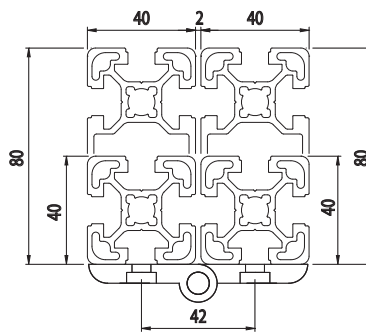

ALUMINIUM HINGE

CERNIERA IN ALLUMINIO
BISAGRA DE ALUMINIO
CHARNIÈRE EN ALUMINIUM
ALUMINIUMSCHARNIER

BH
105
45

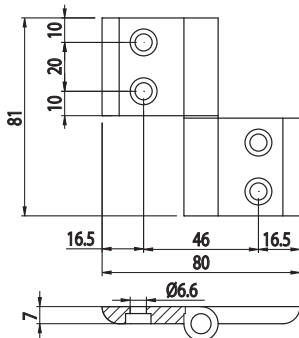
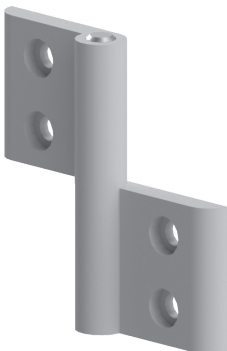

Cod	Note	g
084.500.003	M6x16 DIN 7984 screws not included - Viti TCEI M6x16 non include - Tornillos M6x16 DIN 7984 no incluidos - Vis M6x16 DIN 7984 non fournies - Schrauben M6x16 DIN 7984 nicht inklusive	99

Anodised aluminium

Alluminio anodizzato
Aluminio anodizado
Aluminium anodisé
Eloxiertes Aluminium

AISI 303 stainless-steel pin, Ø8 mm

Perno acciaio inox AISI 303 Ø8
Perno de acero inoxidable AISI 303 Ø8
Pivot acier inox AISI 303 Ø 8
Bolzen aus rostfreiem Stahl AISI 303 Ø8

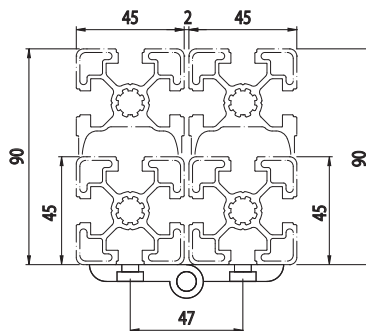

**ALUMINIUM HINGE**

CERNIERA IN ALLUMINIO
BISAGRA DE ALUMINIO
CHARNIÈRE EN ALUMINIUM
ALUMINIUMSCHARNIER

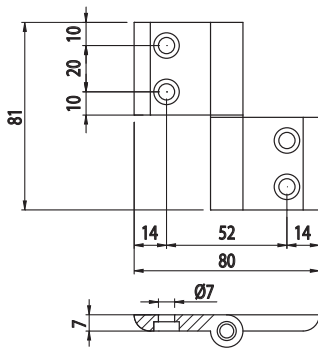
Cod	Note	g
084.500.015	M6x16 DIN 7984 screws not included - Viti M6x16 DIN 7984 non incluse - Tornillos M6x16 DIN 7984, no incluidos - Vis M6x16 DIN 7984 non fournies - Schrauben M6x16 DIN 7984 nicht inklusive	100

Anodised aluminium

Alluminio anodizzato
Aluminio anodizado
Aluminium anodisé
Eloxiertes Aluminium

AISI 303 stainless-steel pin, Ø8 mm

Perno acciaio inox AISI 303 Ø8
Perno de acero inoxidable AISI 303 Ø8
Pivot acier inox AISI 303 Ø 8
Bolzen aus rostfreiem Stahl AISI 303 Ø8

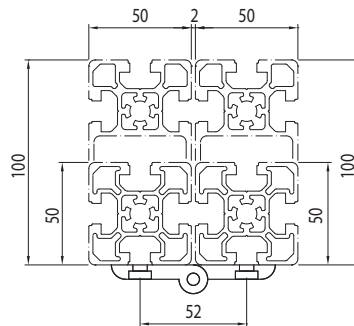
**ALUMINIUM HINGE**

CERNIERA IN ALLUMINIO
BISAGRA DE ALUMINIO
CHARNIÈRE EN ALUMINIUM
ALUMINIUMSCHARNIER

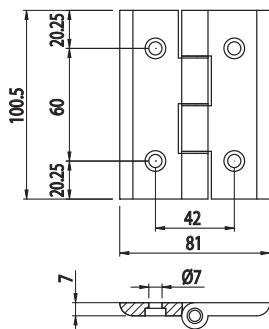
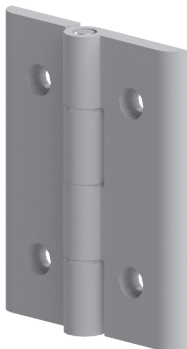
Cod	Note	g
084.500.018	M6x16 DIN 7984 screws not included - Viti M6x16 DIN 7984 non incluse - Tornillos M6x16 DIN 7984, no incluidos - Vis M6x16 DIN 7984 non fournies - Schrauben M6x16 DIN 7984 nicht inklusive	183

Anodised aluminium

Alluminio anodizzato
Aluminio anodizado
Aluminium anodisé
Eloxiertes Aluminium

AISI 303 stainless-steel pin, Ø8 mm

Perno acciaio inox AISI 303 Ø8
Perno de acero inoxidable AISI 303 Ø8
Pivot acier inox AISI 303 Ø 8
Bolzen aus rostfreiem Stahl AISI 303 Ø8

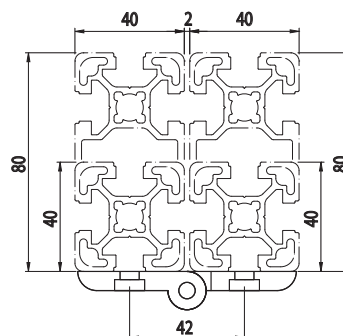



ALUMINIUM HINGE

CERNIERA IN ALLUMINIO
BISAGRA DE ALUMINIO
CHARNIÈRE EN ALUMINIUM
ALUMINIUMSCHARNIER

BH
105
45

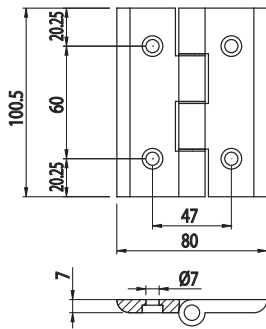

Cod	Note	g
084.500.006	M6x16 DIN 7984 screws not included - Viti M6x16 DIN 7984 non incluse - Tornillos M6x16 DIN 7984 no incluidos - Vis M6x16 DIN 7984 non fournies - Schrauben M6x16 DIN 7984 nicht inklusive	180

Anodised aluminium

Alluminio anodizzato
Aluminio anodizado
Aluminium anodisé
Eloxiertes Aluminium

AISI 303 stainless-steel pin, Ø8 mm

Perno acciaio inox AISI 303 Ø8
Perno de acero inoxidable AISI 303 Ø8
Pivot acier inox AISI 303 Ø8
Bolzen aus rostfreiem Stahl AISI 303 Ø8

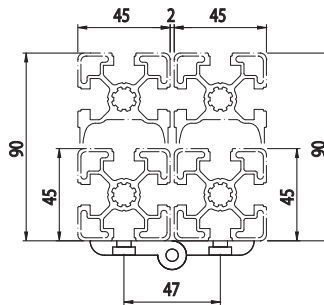

ALUMINIUM HINGE

CERNIERA IN ALLUMINIO
BISAGRA DE ALUMINIO
CHARNIÈRE EN ALUMINIUM
ALUMINIUMSCHARNIER

BH
105
50

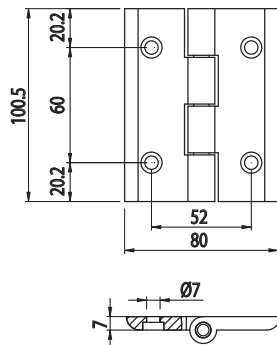

Cod	Note	g
084.500.017	M6x16 DIN 7984 screws not included - Viti M6x16 DIN 7984 non incluse - Tornillos M6x16 DIN 7984, no incluidos - Vis M6x16 DIN 7984 non fournies - Schrauben M6x16 DIN 7984 nicht inklusive	183

Anodised aluminium

Alluminio anodizzato
Aluminio anodizado
Aluminium anodisé
Eloxiertes Aluminium

AISI 303 stainless-steel pin, Ø8 mm

Perno acciaio inox AISI 303 Ø8
Perno de acero inoxidable AISI 303 Ø8
Pivot acier inox AISI 303 Ø8
Bolzen aus rostfreiem Stahl AISI 303 Ø8

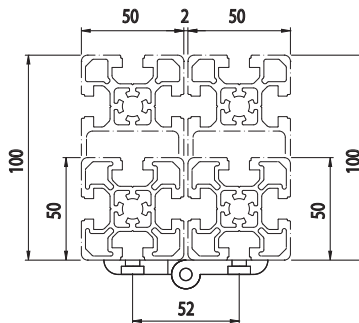

**ALUMINIUM HINGE**

CERNIERA IN ALLUMINIO
BISAGRA DE ALUMINIO
CHARNIÈRE EN ALUMINIUM
ALUMINIUMSCHARNIER

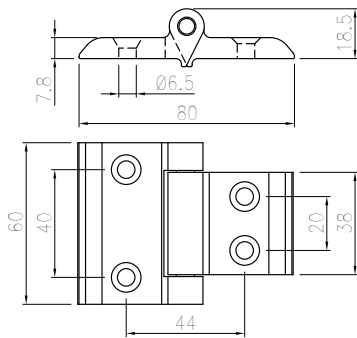
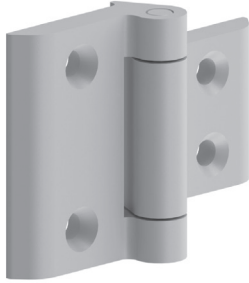

Cod	Note	g
084.500.023	M6x20 DIN 7984 screws not included - Viti M6x20 DIN 7984 non incluse - Tornillos M6x20 DIN 7984 no incluidos - Vis M6x20 DIN 7984 non fournies - Schrauben M6x20 DIN 7984 nicht inklusive	102,5

Anodised aluminium

Alluminio anodizzato
Aluminio anodizado
Aluminium anodisé
Eloxiertes Aluminium

AISI 303 stainless-steel pin, Ø8 mm

Perno acciaio inox AISI 303 Ø8
Perno de acero inoxidable AISI 303 Ø8
Pivot acier inox AISI 303 Ø8
Bolzen aus rostfreiem Stahl AISI 303 Ø8

ALUMINIUM HINGE

CERNIERA IN ALLUMINIO
BISAGRA DE ALUMINIO
CHARNIÈRE EN ALUMINIUM
ALUMINIUMSCHARNIER

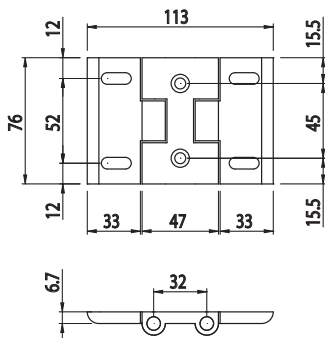
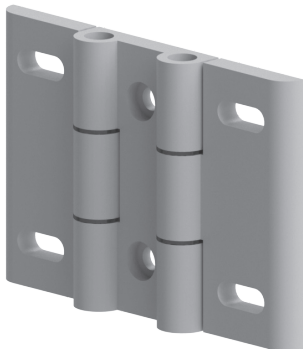

Cod	Note	g
084.500.009	M6x16 DIN 7984 screws not included - Viti M6x16 DIN 7984 non incluse - Tornillos M6x16 DIN 7984 no incluidos - Vis M6x16 DIN 7984 non fournies - Schrauben M6x16 DIN 7984 nicht inklusive	152

Anodised aluminium

Alluminio anodizzato
Aluminio anodizado
Aluminium anodisé
Eloxiertes Aluminium

AISI 303 stainless-steel pin, Ø8 mm

Perno acciaio inox AISI 303 Ø8
Perno de acero inoxidable AISI 303 Ø8
Pivot acier inox AISI 303 Ø8
Bolzen aus rostfreiem Stahl AISI 303 Ø8

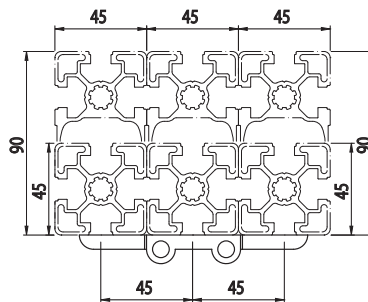



ALUMINIUM HINGE
CERNIERA IN ALLUMINIO
BISAGRA DE ALUMINIO
CHARNIÈRE EN ALUMINIUM
ALUMINIUMSCHARNIER

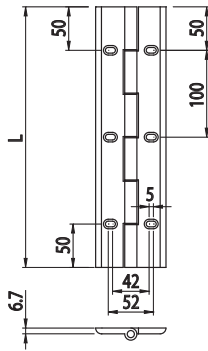

Cod	Note	g
084.500.020	M6x20 DIN 7984 screws not included - Viti M6x20 DIN 7984 non incluse - Tornillos M6x20 DIN 7984 no incluidos - Vis M6x20 DIN 7984 non fournies - Schrauben M6x20 DIN 7984 nicht inklusive	1,80

Anodised aluminium
Alluminio anodizzato
Aluminio anodizado
Aluminium anodisé
Eloxiertes Aluminium

Materiale inglese
Materiale italiano
Materiale spagnolo
Materiale francese
Materiale tedesco

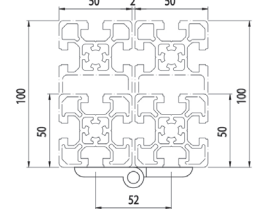
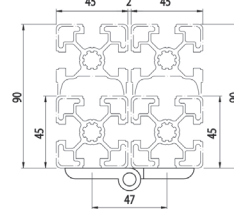
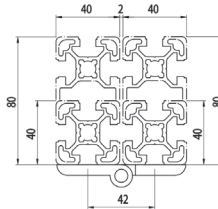

CODE FOR ORDER
CODICE PER ORDINE / CÓDIGO PARA PEDIR
CODE POUR ORDRE / TEIL NR. ZUR BESTELLUNG



- L external hinge length (multiple sizes of 100mm, min. 200/ max 3000mm)**
- L lunghezza esterna della cerniera (misure multiple di 100mm, min 200/ max 3000mm)
- L longitud externa de la bisagra (medidas múltiples de 100mm, min 200/ max 3000mm)
- L longueur extérieure de la charnière (mesures multiples de 100mm, min 200/ max 3000mm)
- L äußere Länge der Scharniere (vielfach von 100mm, min 200/ max 3000mm)

**ALUMINIUM HINGE**

CERNIERA IN ALLUMINIO
BISAGRA DE ALUMINIO
CHARNIÈRE EN ALUMINIUM
ALUMINIUMSCHARNIER

BH
8
30

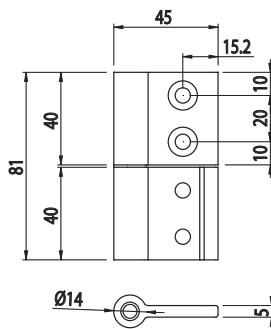
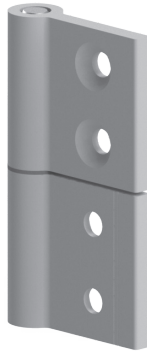

Cod	Note	g
084.500.012	M6x12 UNI 5933 screws not included - Viti M6x12 UNI 5933 non include - Tornillos M6x12 UNI 5933 no incluidos - Vis M6x12 UNI 5933 non fournies - Schrauben M6x12 UNI 5933 nicht inklusive	85

Anodised aluminium

Alluminio anodizzato
Aluminio anodizado
Aluminium anodisé
Eloxiertes Aluminium

AISI 303 stainless-steel pin, Ø8 mm

Perno acciaio inox AISI 303 Ø8
Perno de acero inoxidable AISI 303 Ø8
Pivot acier inox AISI 303 Ø 8
Bolzen aus rostfreiem Stahl AISI 303 Ø8

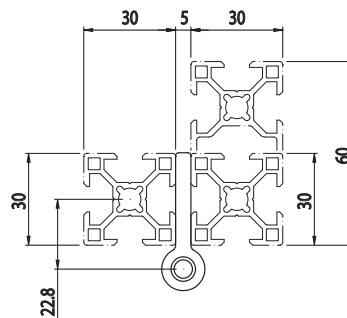
**ALUMINIUM HINGE**

CERNIERA IN ALLUMINIO
BISAGRA DE ALUMINIO
CHARNIÈRE EN ALUMINIUM
ALUMINIUMSCHARNIER

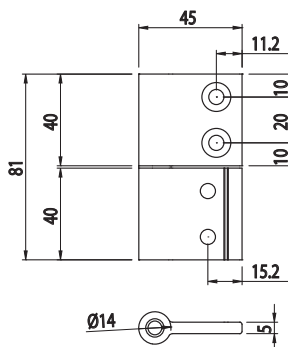

Cod	Note	g
084.500.021	M6x12 and M6x16 UNI 5933 screws not included - Viti M6x12 e M6x16 UNI 5933 non include - Tornillos M6x12 e M6x16 UNI 5933 no incluidos - Vis M6x12 e M6x16 UNI 5933 non fournies - Schrauben M6x12 e M6x16 UNI 5933 nicht inklusive	85

Anodised aluminium

Alluminio anodizzato
Aluminio anodizado
Aluminium anodisé
Eloxiertes Aluminium

AISI 303 stainless-steel pin, Ø8 mm

Perno acciaio inox AISI 303 Ø8
Perno de acero inoxidable AISI 303 Ø8
Pivot acier inox AISI 303 Ø 8
Bolzen aus rostfreiem Stahl AISI 303 Ø8

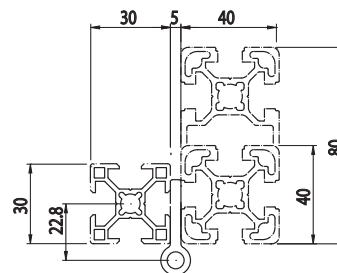



ALUMINIUM HINGE

CERNIERA IN ALLUMINIO
BISAGRA DE ALUMINIO
CHARNIÈRE EN ALUMINIUM
ALUMINIUMSCHARNIER

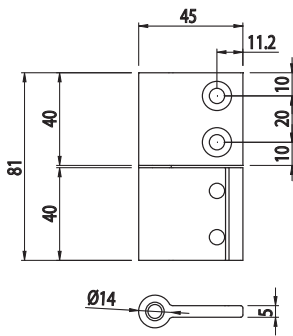

Cod	Note	g
084.500.011	M6x16 UNI 5933 screws not included - Viti M6x16 UNI 5933 non include - Tornillos M6x16 UNI 5933 no incluidos - Vis M6x16 UNI 5933 non fournies - Schrauben M6x16 UNI 5933 nicht inklusive	85

Anodised aluminium

Alluminio anodizzato
Aluminio anodizado
Aluminium anodisé
Eloxiertes Aluminium

AISI 303 stainless-steel pin, Ø8 mm

Perno acciaio inox AISI 303 Ø8
Perno de acero inoxidable AISI 303 Ø8
Pivot acier inox AISI 303 Ø 8
Bolzen aus rostfreiem Stahl AISI 303 Ø8

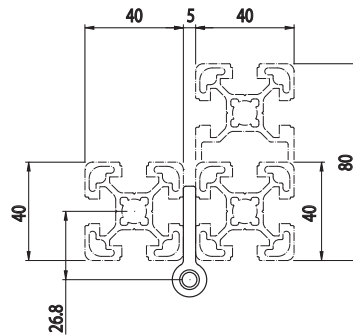

ALUMINIUM HINGE

CERNIERA IN ALLUMINIO
BISAGRA DE ALUMINIO
CHARNIÈRE EN ALUMINIUM
ALUMINIUMSCHARNIER

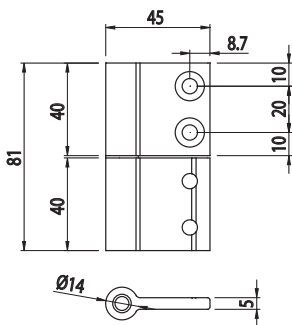
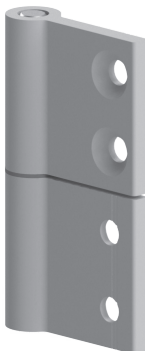

Cod	Note	g
084.500.010	M6x20 UNI 5933 screws not included - Viti M6x20 UNI 5933 non include - Tornillos M6x20 UNI 5933 no incluidos - Vis M6x20 UNI 5933 non fournies - Schrauben M6x20 UNI 5933 nicht inklusive	85

Anodised aluminium

Alluminio anodizzato
Aluminio anodizado
Aluminium anodisé
Eloxiertes Aluminium

AISI 303 stainless-steel pin, Ø8 mm

Perno acciaio inox AISI 303 Ø8
Perno de acero inoxidable AISI 303 Ø8
Pivot acier inox AISI 303 Ø 8
Bolzen aus rostfreiem Stahl AISI 303 Ø8

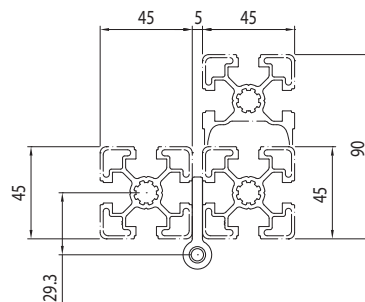

**ZAMAK HINGE**

CERNIERA IN ZAMA
BISAGRA DE ZAMAK
CHARNIÈRE EN ZAMAK
ZAMAKSCHARNIER

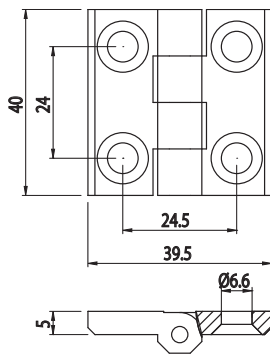
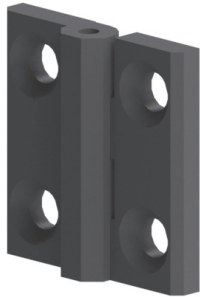

Cod	Note	g
084.501.020	M6x8 UNI 5933 screws not included - Viti M6x8 UNI 5933 non incluse - Tornillos M6x8 UNI 5933 no incluidos - Vis M6x8 UNI 5933 non fournies - Schrauben M6x8 UNI 5933 nicht inklusive	120

Black painted zamak

Zama verniciato nero
Zamak barnizado negro
Zamak peint noir
Schwarz lackierte Zamak-Legierung

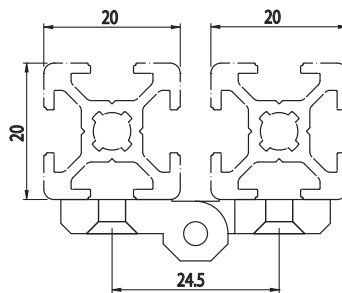
**ZAMAK HINGE**

CERNIERA IN ZAMA
BISAGRA DE ZAMAK
CHARNIÈRE EN ZAMAK
ZAMAKSCHARNIER

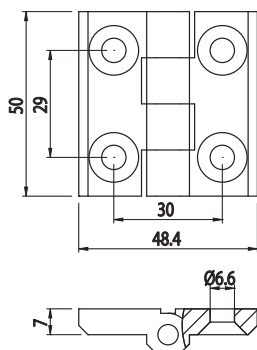
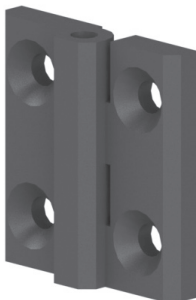

Cod	Note	g
084.501.019	M6x16 UNI 5933 screws not included - Viti M6x16 UNI 5933 non incluse - Tornillos M6x16 UNI 5933 no incluidos - Vis M6x16 UNI 5933 non fournies - Schrauben M6x16 UNI 5933 nicht inklusive	120

Black painted zamak

Zama verniciato nero
Zamak barnizado negro
Zamak peint noir
Schwarz lackierte Zamak-Legierung

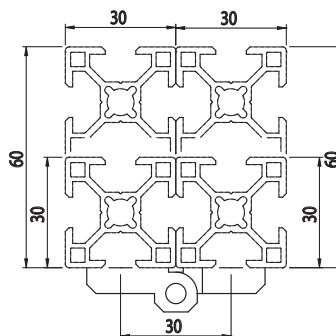



ZAMAK HINGE

CERNIERA IN ZAMA
BISAGRA DE ZAMAK
CHARNIÈRE EN ZAMAK
ZAMAKSCHARNIER

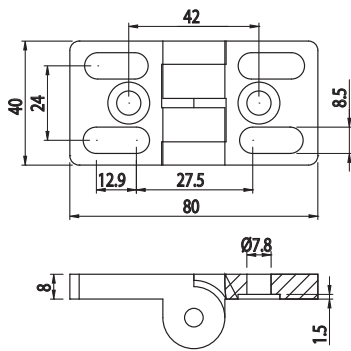
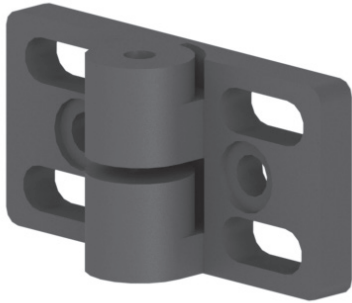

Cod	Note	g
084.501.017	M8x16 DIN 7984 screws - Viti M8x16 DIN 7984 non incluse - Tornillos M8x16 DIN 7984 no incluidos - Vis M8x16 DIN 7984 non fournies - Schrauben M8x16 DIN 7984 nicht inklusive	215

Black painted zamak

Zama verniciato nero
Zamak barnizado negro
Zamak peint noir
Schwarz lackierte Zamak-Legierung

**POLYAMIDE HINGE**

CERNIERA IN POLIAMMIDE
BISAGRA DE POLIAMIDA
CHARNIÈRE EN POLYAMIDE
POLYAMIDSCHARNIER

BH
6
20

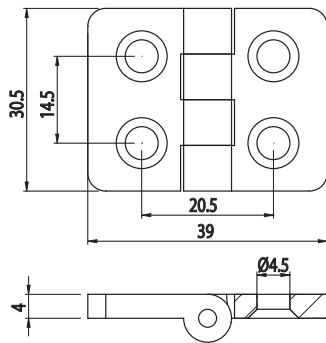
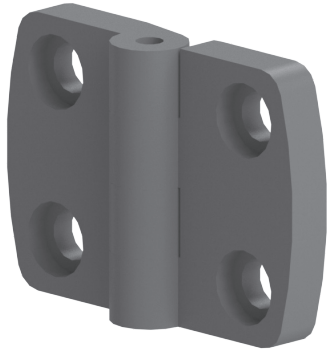

Cod	Note	g
084.501.011	M4x8 UNI 5933 screws not included - Viti M4x8 UNI 5933 non incluse - Tornillos M4x8 UNI 5933 no incluidos - Vis M4x8 UNI 5933 non fournies - Schrauben M4x8 UNI 5933 nicht inklusive	13

Black polyamide

Poliammide nero
Poliamida color negro
Polyamide noir
Schwarzes Polyamid

AISI 303 stainless-steel pin, Ø5 mm

Perno acciaio inox AISI 303 Ø5
Perno de acero inoxidable AISI 303 Ø5
Pivot acier inox AISI 303 Ø 5
Bolzen aus rostfreiem Stahl AISI 303 Ø5

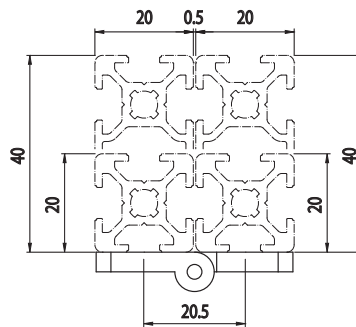
**POLYAMIDE HINGE**

CERNIERA IN POLIAMMIDE
BISAGRA DE POLIAMIDA
CHARNIÈRE EN POLYAMIDE
POLYAMIDSCHARNIER

BH
8
30

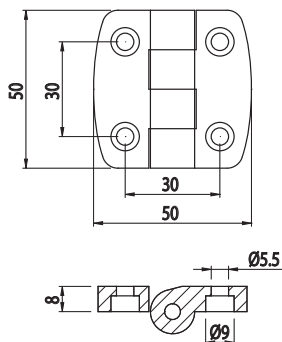
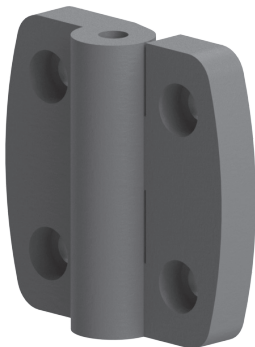

Cod	Note	g
084.501.008	M5x16 DIN 7984 screws not included - Viti M5x16 DIN 7984 non incluse - Tornillos M5x16 DIN 7984 no incluidos - Vis M5x16 DIN 7984 non fournies - Schrauben M5x16 DIN 7984 nicht inklusive	32

Black polyamide

Poliammide nero
Poliamida color negro
Polyamide noir
Schwarzes Polyamid

AISI 303 stainless-steel pin, Ø5 mm

Perno acciaio inox AISI 303 Ø5
Perno de acero inoxidable AISI 303 Ø5
Pivot acier inox AISI 303 Ø 5
Bolzen aus rostfreiem Stahl AISI 303 Ø5

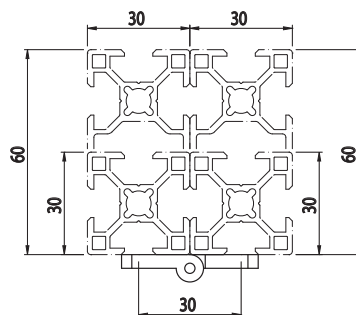



POLYAMIDE HINGE

CERNIERA IN POLIAMMIDE
BISAGRA DE POLIAMIDA
CHARNIÈRE EN POLYAMIDE
POLYAMIDSCHARNIER

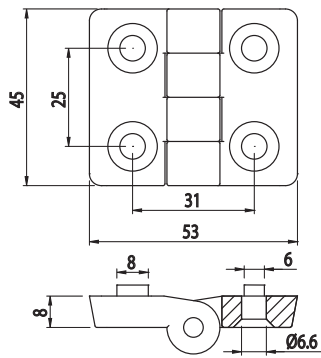
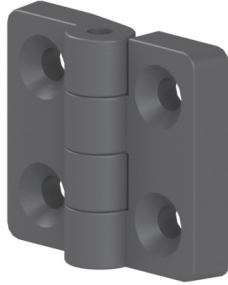

Cod	Note	g
084.501.013	M6x16 UNI 5933 screws not included - Viti M6x16 UNI 5933 non include - Tornillos M6x16 UNI 5933 no incluidos - Vis M6x16 UNI 5933 non fournies - Schrauben M6x16 UNI 5933 nicht inklusive	26

Black polyamide

Poliammide nero
Poliamida color negro
Polyamide noir
Schwarzes Polyamid

AISI 303 stainless-steel pin, Ø5 mm

Perno acciaio inox AISI 303 Ø5
Perno de acero inoxidable AISI 303 Ø5
Pivot acier inox AISI 303 Ø 5
Bolzen aus rostfreiem Stahl AISI 303 Ø5

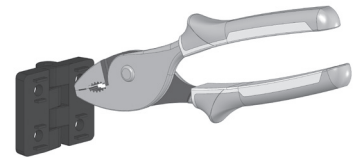
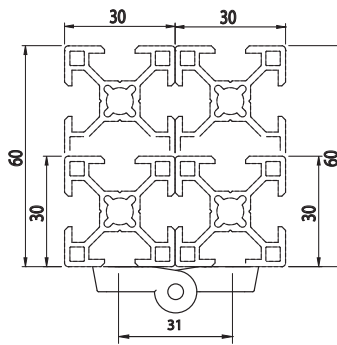

POLYAMIDE HINGE

CERNIERA IN POLIAMMIDE
BISAGRA DE POLIAMIDA
CHARNIÈRE EN POLYAMIDE
POLYAMIDSCHARNIER

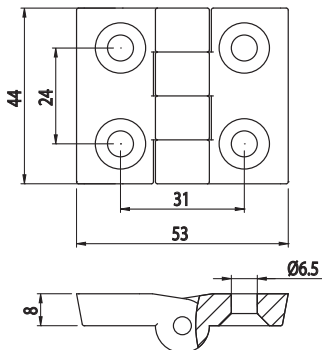
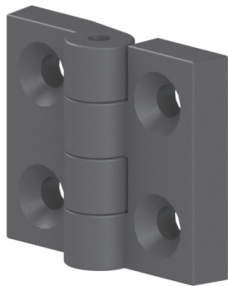

Cod	Note	g
084.501.021	M6x16 UNI 5933 screws not included - Viti M6x16 UNI 5933 non include - Tornillos M6x16 UNI 5933 no incluidos - Vis M6x16 UNI 5933 non fournies - Schrauben M6x16 UNI 5933 nicht inklusive	29

Black polyamide

Poliammide nero
Poliamida color negro
Polyamide noir
Schwarzes Polyamid

AISI 303 stainless-steel pin, Ø5 mm

Perno acciaio inox AISI 303 Ø5
Perno de acero inoxidable AISI 303 Ø5
Pivot acier inox AISI 303 Ø 5
Bolzen aus rostfreiem Stahl AISI 303 Ø5

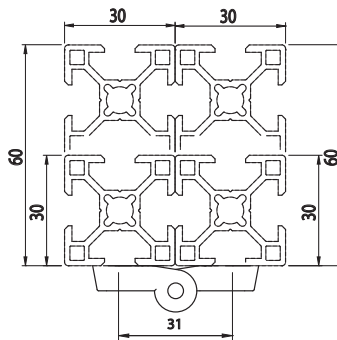

**POLYAMIDE HINGE**

CERNIERA IN POLIAMMIDE
BISAGRA DE POLIAMIDA
CHARNIÈRE EN POLYAMIDE
POLYAMIDSCHARNIER

BH
105
40

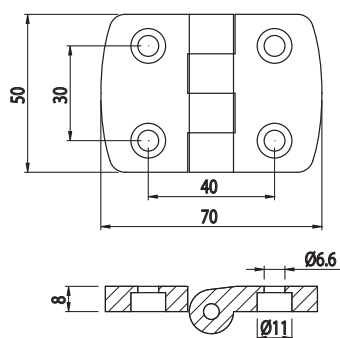
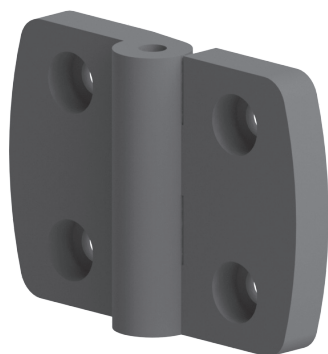

Cod	Note	g
084.501.009	M6x12 DIN 7984 screws not included - Viti TCEI M6x12 DIN 7984 non incluse - Tornillos M6x12 DIN 7984 no incluidos - Vis M6x12 DIN 7984 non fournies - Schrauben M6x12 DIN 7984 nicht inklusive	40

Black polyamide

Poliammide nero
Poliamida color negro
Polyamide noir
Schwarzes Polyamid

AISI 303 stainless-steel pin, Ø5 mm

Perno acciaio inox AISI 303 Ø5
Perno de acero inoxidable AISI 303 Ø5
Pivot acier inox AISI 303 Ø 5
Bolzen aus rostfreiem Stahl AISI 303 Ø5

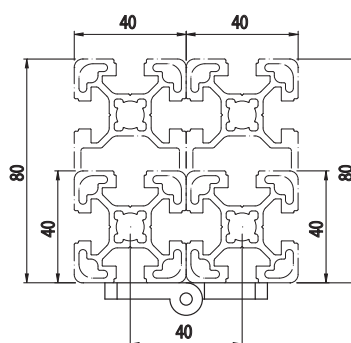
**POLYAMIDE HINGE**

CERNIERA IN POLIAMMIDE
BISAGRA DE POLIAMIDA
CHARNIÈRE EN POLYAMIDE
POLYAMIDSCHARNIER

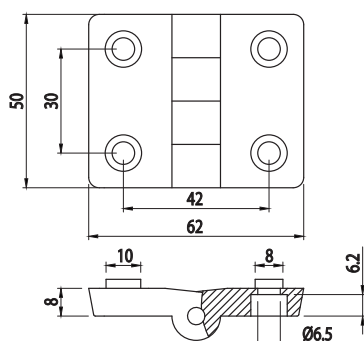

Cod	Note	g
084.501.014	M8x12 DIN 7984 screws not included - Viti M8x12 DIN 7984 non incluse - Tornillos M8x12 DIN 7984 no incluidos - Vis M8x12 DIN 7984 non fournies - Schrauben M8x12 DIN 7984 nicht inklusive	37

Black polyamide

Poliammide nero
Poliamida color negro
Polyamide noir
Schwarzes Polyamid

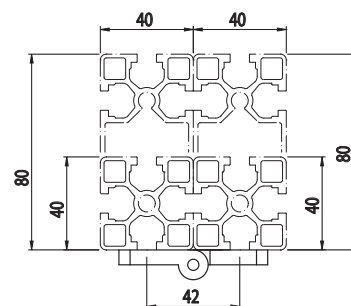



POLYAMIDE HINGE

CERNIERA IN POLIAMMIDE
BISAGRA DE POLIAMIDA
CHARNIÈRE EN POLYAMIDE
POLYAMIDSCHARNIER

BH
105
45

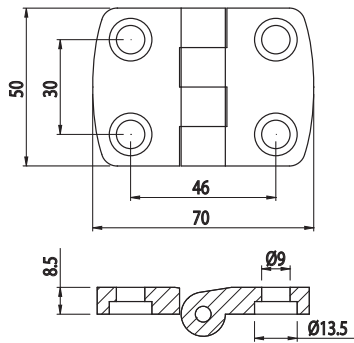
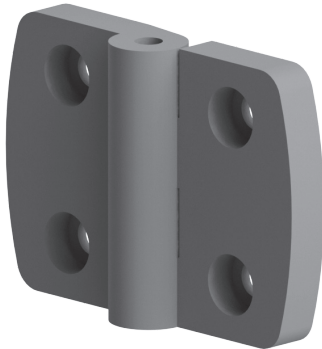

Cod	Note	g
084.501.010	M8x16 DIN 7984 screws not included - Viti M8x16 DIN 7984 non include - Tornillos M8x16 DIN 7984 no incluidos - Vis M8x16 DIN 7984 non fournies - Schrauben M8x16 DIN 7984 nicht inklusive	39

Black polyamide

Poliammide nero
Poliamida color negro
Polyamide noir
Schwarzes Polyamid

AISI 303 stainless-steel pin, Ø5 mm

Perno acciaio inox AISI 303 Ø5
Perno de acero inoxidable AISI 303 Ø5
Pivot acier inox AISI 303 Ø 5
Bolzen aus rostfreiem Stahl AISI 303 Ø5

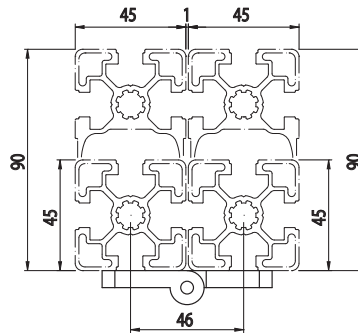

POLYAMIDE HINGE

CERNIERA IN POLIAMMIDE
BISAGRA DE POLIAMIDA
CHARNIÈRE EN POLYAMIDE
POLYAMIDSCHARNIER

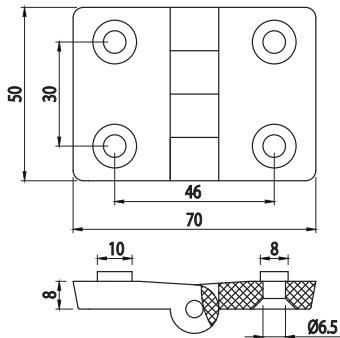
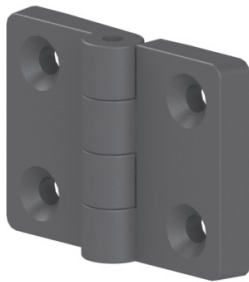

Cod	Note	g
084.501.015	Screws M8x20 UNI 5933 not included - Viti M8x20 UNI 5933 non include - Tornillos M8x20 UNI 5933 no incluidos - Vis M8x20 UNI 5933 non fournies - Schrauben M8x20 UNI 5933 nicht inklusive	44

Black polyamide

Poliammide nero
Poliamida color negro
Polyamide noir
Schwarzes Polyamid

AISI 303 stainless-steel pin, Ø5 mm

Perno acciaio inox AISI 303 Ø5
Perno de acero inoxidable AISI 303 Ø5
Pivot acier inox AISI 303 Ø 5
Bolzen aus rostfreiem Stahl AISI 303 Ø5

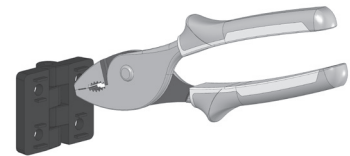
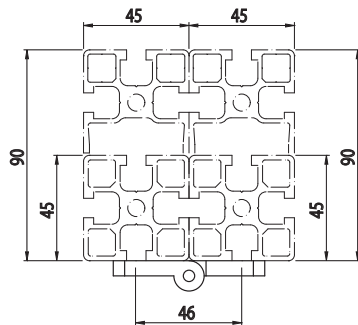

**POLYAMIDE HINGE**

CERNIERA IN POLIAMMIDE
BISAGRA DE POLIAMIDA
CHARNIÈRE EN POLYAMIDE
POLYAMIDSCHARNIER

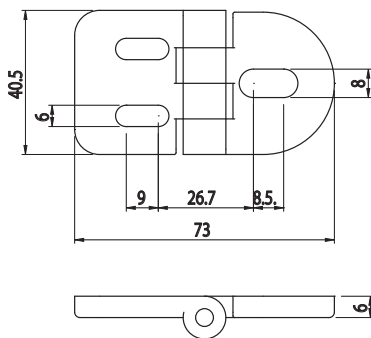

Cod	Note	g
084.501.016	M5 and M8 DIN 7984 screws not included - Viti M5 e M8 DIN 7984 non incluse - Tornillos M5 y M8 DIN 7984 no incluidos - Vis M5 et M8 DIN 7984 non fournies - Schrauben M5 und M8 DIN 7984 nicht inklusive	25

Black polyamide
Poliammide nero
Poliamida color negro
Polyamide noir
Schwarzes Polyamid

AISI 303 stainless-steel pin, Ø5 mm
Perno acciaio inox AISI 303 Ø5
Perno de acero inoxidable AISI 303 Ø5
Pivot acier inox AISI 303 Ø 5
Bolzen aus rostfreiem Stahl AISI 303 Ø5



HANDLE
MANIGLIA
ASIDERO
POIGNÉE
GRIFF

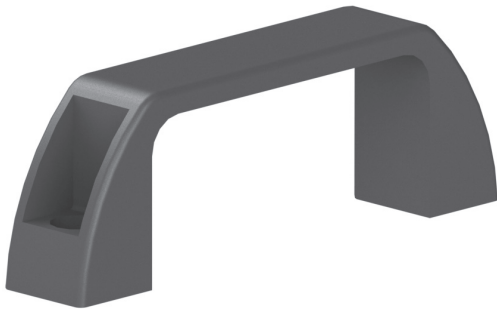

Cod	Note	d	A	D	B	s	g
084.504.001	-	6,50	108	38	93	21	26
084.504.002	-	9	129	44	112,5	28	34
084.504.003	-	9	146	44	128,50	28,5	37

Black polyamide
Poliammide nero
Poliamida color negro
Polyamide noir
Schwarzes Polyamid

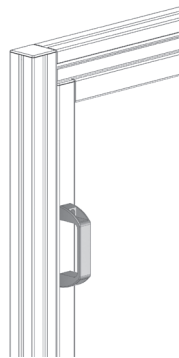
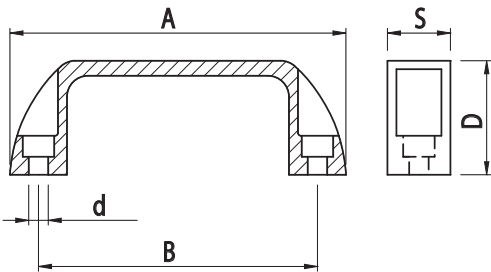

HANDLE
MANIGLIA
ASIDERO
POIGNÉE
GRIFF

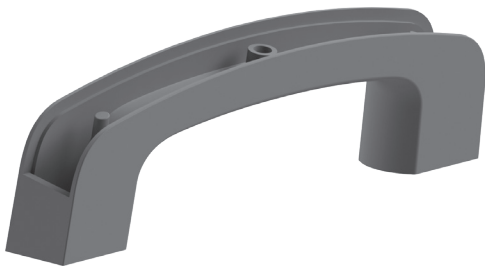

Cod	Note	g
013.506.009	Inclined handle - Maniglia inclinata - Asidero inclinado - Poignée inclinée - Geneigter Griff	42,6

PA6+GF, RAL 7023

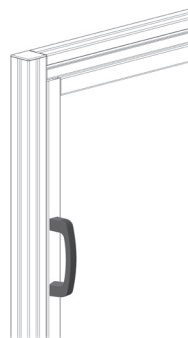
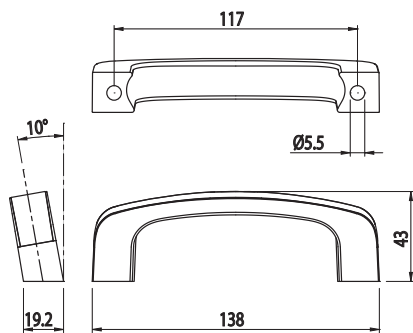

Tappo - Cap - Tapon - Embout - Abdeckkappe			
Cod	Mat	g	Col
013.506.010A	PA6GF	10	■
013.506.010G	PA6GF	10	■

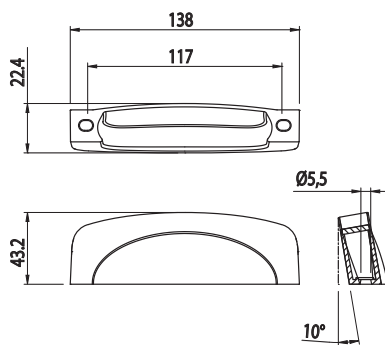
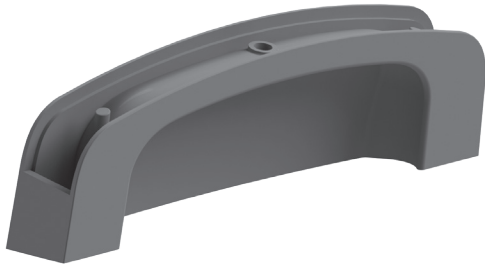

**HANDLE**

MANIGLIA
ASIDERO
POIGNÉE
GRIFF



Cod	Note	g
013.506.008	Inclined handle - Maniglia inclinata - Asidero inclinado - Poignée inclinée - Geneigter Griff	47,1

PA6+GF, RAL 7023

Tappo - Cap - Tapón - Embout - Abdeckkappe			
Cod	Mat	g	Col
013.506.010A	PA6GF	10	
013.506.010G	PA6GF	10	

HANDLE

MANIGLIA
ASIDERO
POIGNÉE
GRIFF

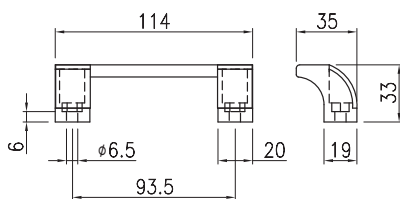
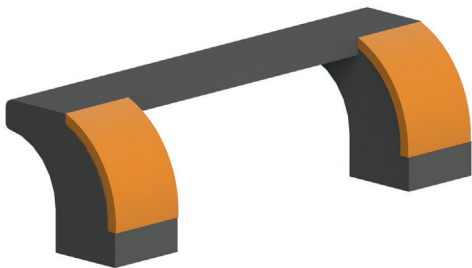

Cod	Note	g
084.506.011	D-handle with orange inserts - Maniglia a ponte con inserti arancioni - Asidero en forma de puente con insertos naranjas - Poignée à pont avec inserts oranges - Brückengriff mit orangefarbenen Einsätzen	29

Black polyamide
Poliammide nero
Poliàmida color negro
Polyamide noir
Schwarzes Polyamid

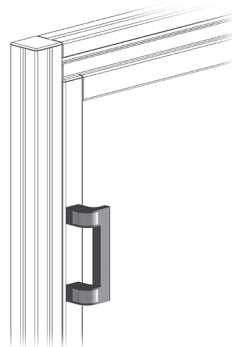



HANDLE
MANIGLIA
ASIDERO
POIGNÉE
GRIFF



Cod	Note	g
084.506.005A		46
084.506.005B		46
084.506.005N		46

Black polyamide
Poliammide nero
Poliamida color negro
Polyamide noir
Schwarzes Polyamid

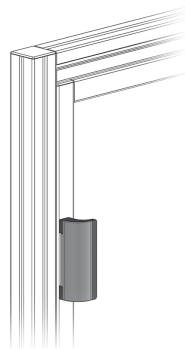
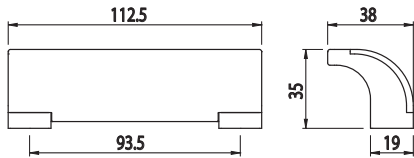

HANDLE
MANIGLIA
ASIDERO
POIGNÉE
GRIFF



Cod	Note	g
084.506.008	Open - Aperta - Abierta - Ouverte - Offen	25

RAL 7023 polyamide
Poliammide RAL 7023
Poliamida color RAL 7023
Polyamide RAL 7023
Polyamid RAL 7023

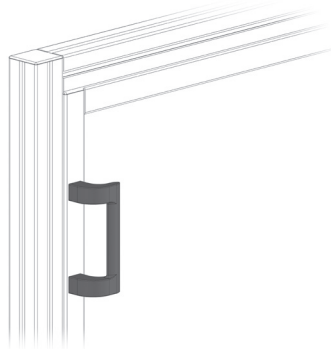
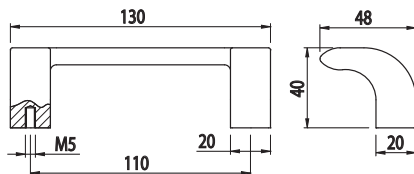

**SPRING HANDLE**

MANIGLIA A MOLLA
ASIDERO DE RESORTE
POIGNÉE À RESSORT
GRIFF MIT FEDER

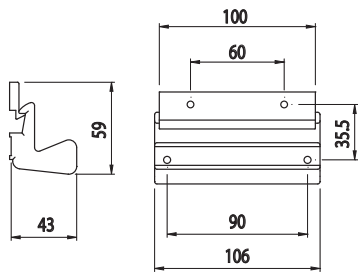
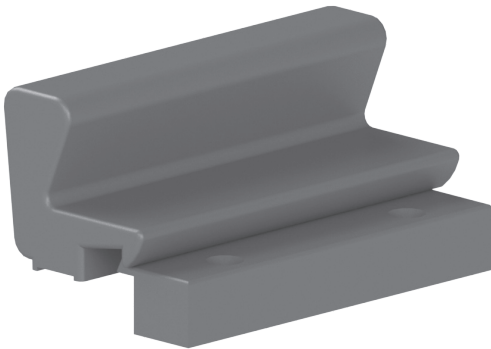

Cod	Note	g
084.506.003	Suitable for sliding door closing - Adatta all'aggancio di sportelli scorrevoli - Apta para el engancho de puertas correizas - Adaptée à la fixation de volets coulissants - Zum Schließen von Schiebetüren geeignet	185

Black painted steel, grey polyamide

Alluminio verniciato nero poliammide grigio
Aluminio barnizado en negro y poliamida color gris
Aluminium peint noir polyamide gris
Aluminium - schwarz lackiert und Polyamid grau

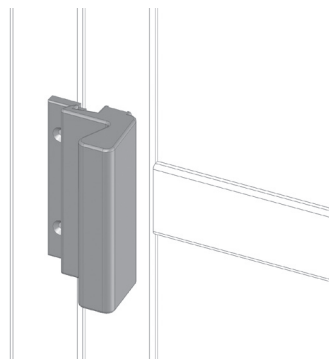
**TUBULAR HANDLE**

MANIGLIA A TUBO
ASIDERO DE TUBO
POIGNÉE À TUBE
ROHRGRIFF

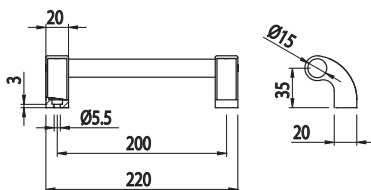

Cod	Note	g
084.506.007N	Ø15 mm anodised tube - Tubo anodizzato Ø15 - Tubo anodizado Ø15 - Tube anodisé Ø 15 - Eloxiertes Rohr Ø15	65

Anodised aluminium

Alluminio anodizzato
Aluminio anodizado
Aluminium anodisé
Eloxiertes Aluminium

Black polyamide

Poliammide nero
Poliamida color negro
Polyamide noir
Schwarzes Polyamid

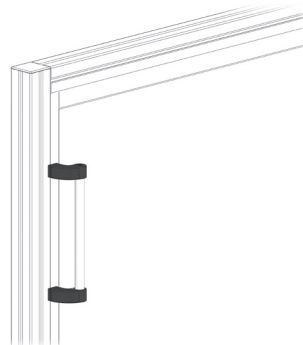



TUBULAR HANDLE

MANIGLIA A TUBO
ASIDERO DE TUBO
POIGNÉE À TUBE
ROHRGRIFF

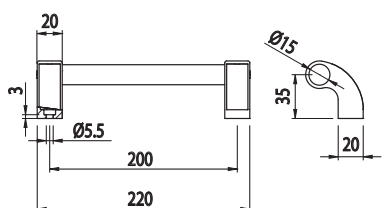

Cod	Note	g
084.506.007NR	Ø15 mm rubberised tube - Tubo gommato Ø15 - Tubo engomado Ø15 - Tube caoutchouté Ø 15 - Kautschutiertes Rohr Ø15	65

Anodised aluminium

Alluminio anodizzato
Aluminio anodizado
Aluminium anodisé
Eloxiertes Aluminium

Black polyamide

Poliamide nero
Poliamide color negro
Polyamide noir
Schwarzes Polyamid

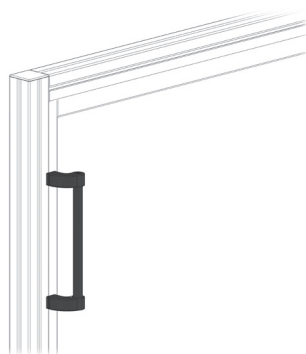

TUBULAR HANDLE

MANIGLIA A TUBO
ASIDERO DE TUBO
POIGNÉE À TUBE
ROHRGRIFF

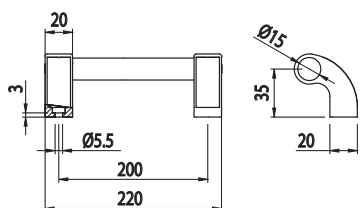

Cod	Note	g
084.506.007G	Ø15 mm anodised tube - Tubo anodizzato Ø15 - Tubo anodizado Ø15 - Tube anodisé Ø 15 - Eloxiertes Rohr Ø15	65

Anodised aluminium

Alluminio anodizzato
Aluminio anodizado
Aluminium anodisé
Eloxiertes Aluminium

Grey polyamide

Poliamide grigio
Poliamide color gris
Polyamide gris
Graues Polyamid

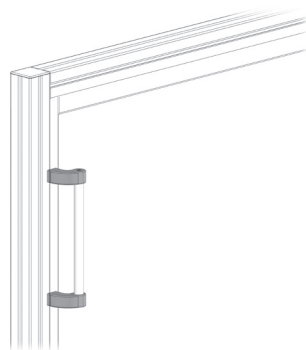

**TUBULAR HANDLE**

MANIGLIA A TUBO
ASIDERO DE TUBO
POIGNÉE À TUBE
ROHRGRIFF



Cod	Note	g
084.506.007GR	Ø15 mm rubberised tube - Tubo gommato Ø15 - Tubo engomado Ø15 - Tube caoutchouté Ø15 - Kautschutiertes Rohr Ø15	65

Anodised aluminium

Alluminio anodizzato
Aluminio anodizado
Aluminium anodisé
Eloxiertes Aluminium

Grey polyamide

Poliammide grigio
Poliamida color gris
Polyamide gris
Graues Polyamid

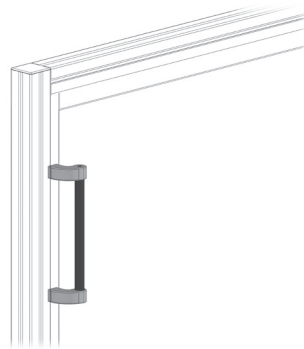
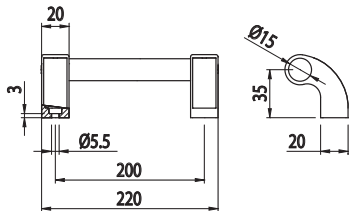



SUPPORTS FOR HANDLE

SUPPORTI PER MANIGLIA
SOPORTES PARA ASIDERO
SUPPORTS POUR POIGNÉE
HALTERUNG FÜR GRIFF



Cod	Note	g
084.506.006	For Ø32 tube - Per tubo Ø32 - Para tubo Ø32 - Pour tube Ø 32 - Für Rohr Ø32	93
084.506.006G	For Ø32 mm tube - Per tubo Ø32 - Para tubo Ø32 - Pour tube Ø 32 - Für Rohr Ø32	93

Black polyamide
Poliammide nero
Poliamida color negro
Polyamide noir
Schwarzes Polyamid

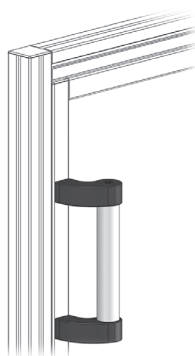
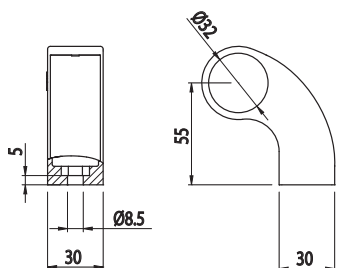

CODE FOR ORDER COMPLETE HANDLE KIT

CODICE PER ORDINE KIT MANIGLIA COMPLETA / CÓDIGO PARA PEDIR EL KIT DE ASIDERO COMPLETO
CODE POUR COMMANDER KIT POIGNÉE COMPLÈTE / TEIL NR. ZUR BESTELLUNG DES KOMPLETTEN GRIFFSATZ

084.506.006

084.506.006G

handle complete with aluminium tube Ø32
maniglia completa di tubo in alluminio Ø32
manija con tubo en aluminio Ø32
poignée avec tube en aluminium Ø32
Griff mit Aluminium Rohr Ø32

I distance between the supports
I interasse tra i due supporti
I distancia entre los dos soportes
I distance entre les deux supports
I Abstand zwischen den zwei Halter

Tube / tubo / tubo / tube / Rohr
A anodized / anodizzato / anodizado / anodisé / eloxiert
B blu coated / verniciato blu / pintado azul / peint en bleu / Blau lackiert
R rubberised / gommato / cauchutado / caoutchouté / gummiert

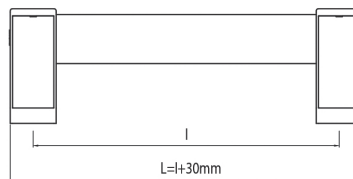

Tube / tubo / tubo / tube / Rohr = I+25mm

**TUBE FOR HANDLE**

TUBO PER MANIGLIA
TUBO PARA ASIDERO
TUBE POUR POIGNÉE
ROHR FÜR GRIFF

Cod	Note	kg/m
084.506.006PA	Ø32 mm	0,35

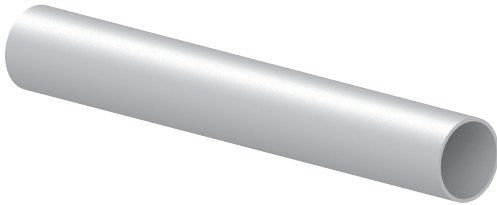
**Anodised aluminium**

Alluminio anodizzato
Aluminio anodizado
Aluminium anodisé
Eloxiertes Aluminium
L=6040 mm

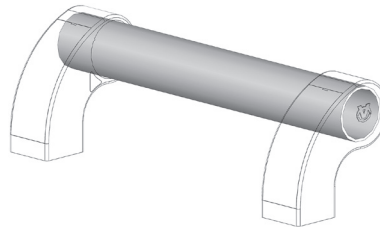
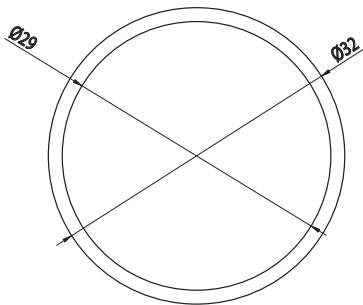
**TUBE FOR HANDLE**

TUBO PER MANIGLIA
TUBO PARA ASIDERO
TUBE POUR POIGNÉE
ROHR FÜR GRIFF

Cod	Note	kg/m
059.032.029	Ø32 mm	0,35

**Blue painted aluminium**

Alluminio verniciato blu
Aluminio barnizado en azul
Aluminium peint bleu
Lackiertes Aluminium blau
L=2000mm

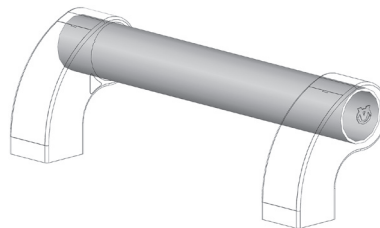
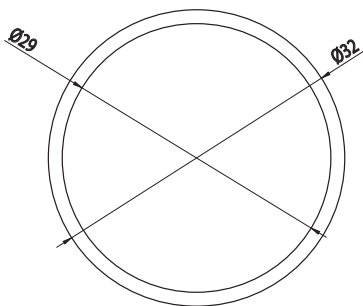



SHEATH FOR TUBE, Ø 32 mm

GUAINA PER TUBO
 REVESTIMIENTO PARA TUBO Ø 32
 GAINÉ POUR TUBE Ø 32
 HÜLLE FÜR ROHR Ø32

Cod	Note	g/m
084.506.006R	Ø 32 mm	30

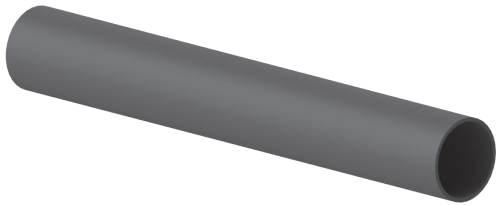

Heat-shrink black rubber
 Gomma nera termorestringente
 Goma negra termorretráctil
 Caoutchouc noir thermorétractable
 Wärmeschrumpf schwarzer Gummi

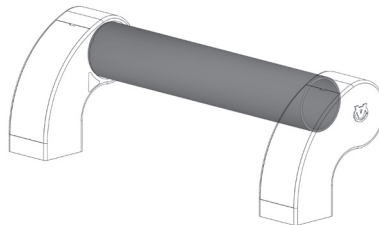
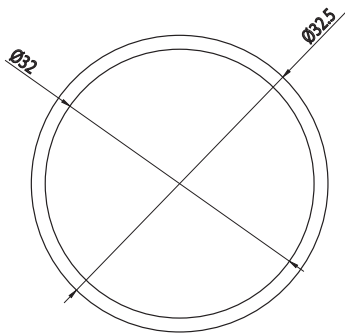

SUPPORTS FOR HANDLE

SUPPORTI PER MANIGLIA
 SOPORTES PARA ASIDERO
 SUPPORTS POUR POIGNÉE
 HALTERUNG FÜR GRIFF

Cod	Note	g
084.506.009A	For Ø25 tube - Per tubo Ø25 - Para tubo Ø25 - Pour tube Ø25 - Für Rohr Ø25	9,6



PA6+GF, RAL 7023

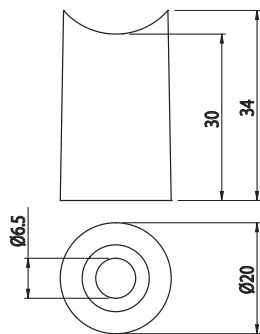

**HANDLE CAPS**

TAPPI MANIGLIA
TAPAS MANEJAR
EMBOUS POIGNÉE
ABDECKKAPPEN FÜR GRIFF

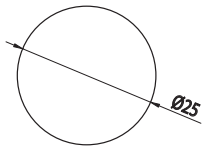
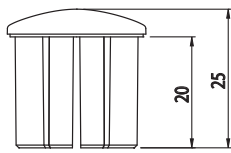
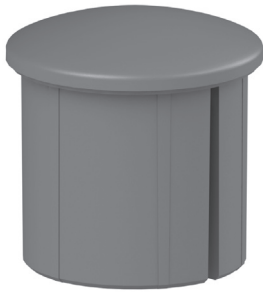

Cod	Note	g
084.506.009B	For Ø25 tube - Per tubo Ø25 - Para tubo Ø25 - Pour tube Ø25 - Für Rohr Ø25	4,7

PA6+GF, RAL 7023**TUBE FOR HANDLE**

TUBO PER MANIGLIA
TUBO PARA ASIDERO
TUBE POUR POIGNÉE
ROHR FÜR GRIFF

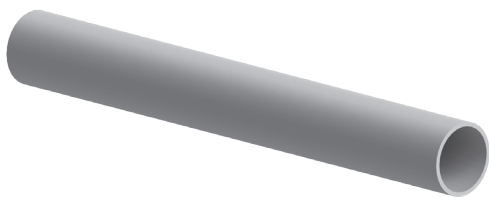

Cod	Note	g
084.506.009PA	Ø25 mm	0,3

Anodised aluminium

Alluminio anodizzato
Aluminio anodizado
Aluminium anodisé
Eloxiertes Aluminium
L=6040 mm

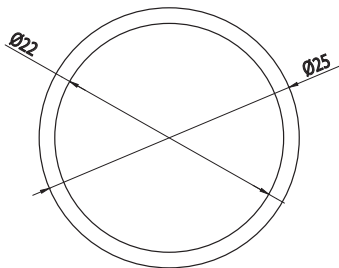



DOOR LEAF CLOSURE

SCROCCHETTO CHIUDI ANTA
CIERRE
LOQUET FERMETURE BATTANT
TÜRVERSCHLUSS

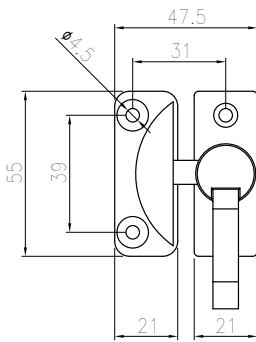
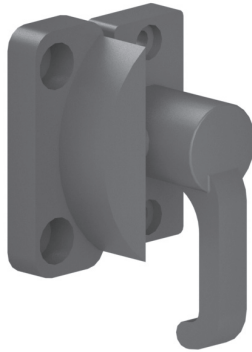

Cod	Note	g
084.517.001	1 RH + 1 LH complete with self-tapping screws - 1 Dx + 1 Sx completo di viti autofilettanti - 1 droit + 1 gauche doté de vis taraudeuses 1 dcho. + 1 izdo., incluye tornillos autorroscantes - 1 Re + 1 Li einschließlich gewindeformender Schrauben	34

Black polyamide

Poliammide nero
Poliamida color negro
Polyamide noir
Schwarzes Polyamid

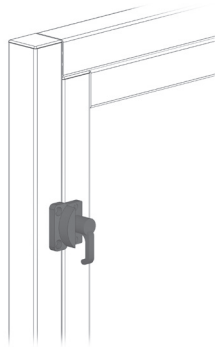

SPRING CLOSURE

SCROCCHETTO A MOLLA
CIERRE DE RESORTE
LOQUET À RESSORT
FEDERVERSCHLUSS

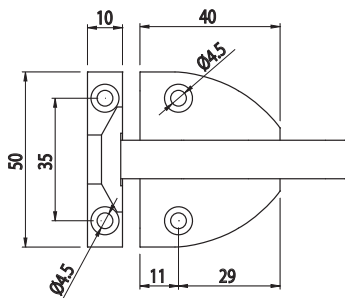
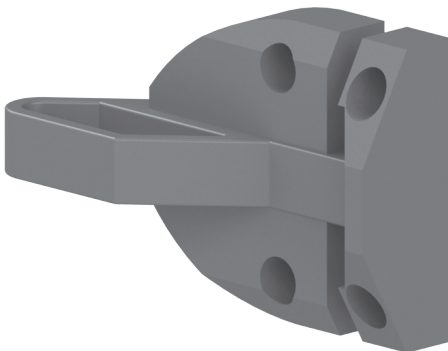

Cod	Note	g
084.518.002	Complete with self-tapping screws - Completo viti autofilettanti - Incluye tornillos autorroscantes - Doté de vis taraudeuses - Einschließlich gewindeformender Schrauben	33

Black polyamide

Poliammide nero
Poliamida color negro
Polyamide noir
Schwarzes Polyamid

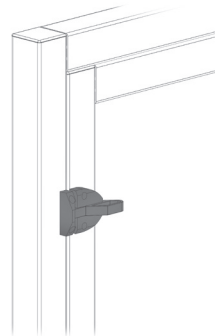

**LOCK WITH KEY**

SERRATURA A CHIAVE
CERRADURA DE LLAVE
SERRURE À CLÉ
SCHLÜSSELSCHLOSS

Cod	Note	g
084.519.001	Complete with key - Completo di chiave - Incluye llave - Doté de clé - Einschließlich Schlüssel	190

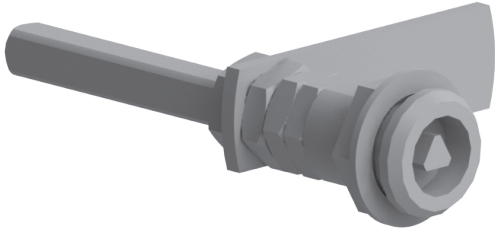
**Galvanised steel**

Acciaio zincato
Acero galvanizado
Acier zingué
Verzinkter Stahl

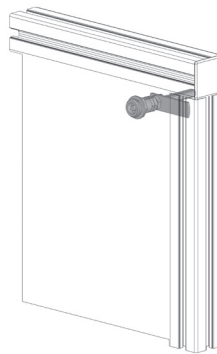
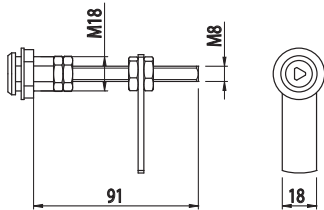
**LOCK WITH KEY**

SERRATURA A CHIAVE
CERRADURA DE LLAVE
SERRURE À CLÉ
SCHLÜSSELSCHLOSS

Cod	Note	g
013.100.030	Key not included - Chiave non inclusa - Clave no incluida - Clé non fournie - Schlüssel nicht inklusiv	46

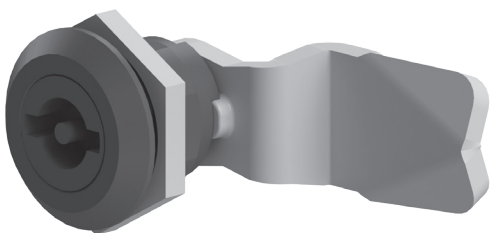
**Galvanised steel**

Acciaio zincato
Acero galvanizado
Acier zingué
Verzinkter Stahl

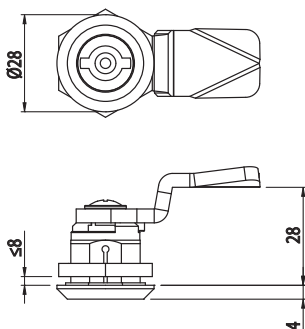

Lavorazione su pannello

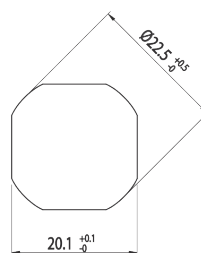

Chiave - Key - Llave - Clé - Schlüssel			
			
Cod	Mat	g	Col
013.100.031	Zamak	0,5	■



LOCK WITH KEY

SERRATURA A CHIAVE
CERRADURA DE LLAVE
SERRURE À CLÉ
SCHLÜSSELSCHLOSS

Cod	Note	g
013.100.032	Key not included - Chiave non inclusa - Clave no incluida - Clé non fournie - Schlüssel nicht inklusiv	81

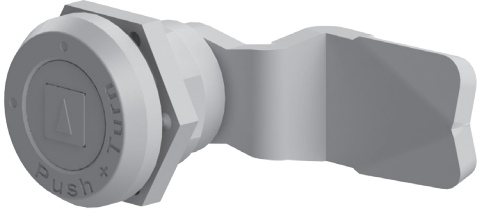

Galvanised steel

Acciaio zincato
Acero galvanizado
Acier zingué
Verzinkter Stahl

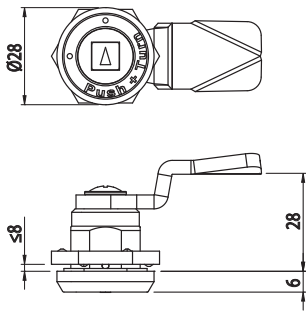

Lavorazione su pannello

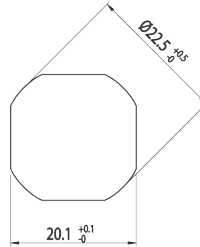

Chiave - Key - Llave - Clé - Schlüssel			
Cod	Mat	g	Col
013.100.033	Zamak	0,5	■

DOOR CLOSURE CLIPS

CLIPS FERMAPORTE
CLIPS DE TOPE DE PUERTAS
CLIPS DE FERMETURE PORTES
TÜRSTOPPERCLIPS

Cod	Note	g
084.519.002	Complete with strike plate - Completo di piastrina di appoggio - Incluye placa de apoyo - Doté de plaquelette d'appui - Einschließlich Tragplatte	39

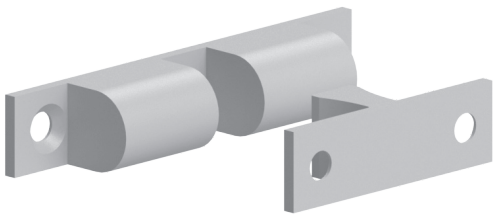

Brass

Ottone
Latón
Laiton
Messing

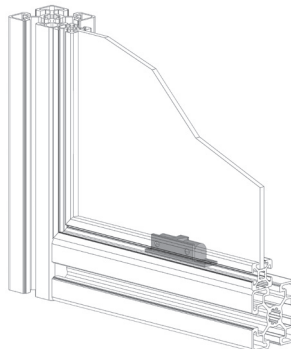
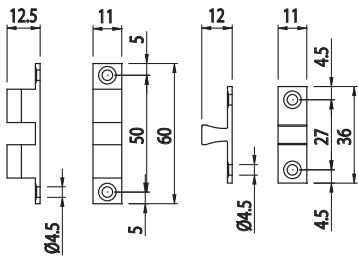

**DOOR CLOSURE CLIPS**

CLIPS FERMAPORTE
CLIPS DE TOPE DE PUERTAS
CLIPS DE FERMETURE PORTES
TÜRSTOPPERCLIPS

Cod	Note	g
084.519.008	With base plate - Con piastra di appoggio - Con placa base - Avec plaque d'appui - Mit Stützplatte	55

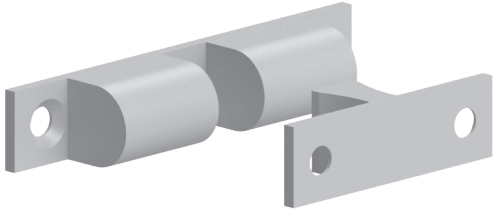

Brass
Ottone
Latón
Laiton
Messing

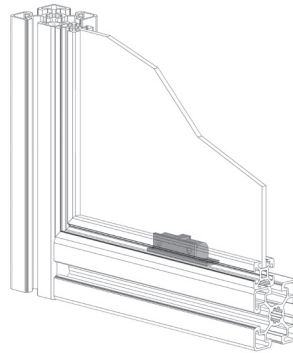
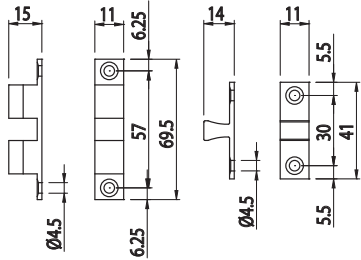
**MAGNET DOOR CLOSER**

FERMAPORTE A CALAMITA
TOPE CON IMÁN
FERMETURE PORTES À AIMANT
MAGNETISCHER TÜRSTOPPER

Cod	Note	g
084.525.001	Complete with strike plate and magnet - Completo di piastrina di appoggio e magnete - Incluye placa de apoyo e imán - Doté de plaquette d'appui et d'aimant - Einschließlich Tragplatte und Magnet	37

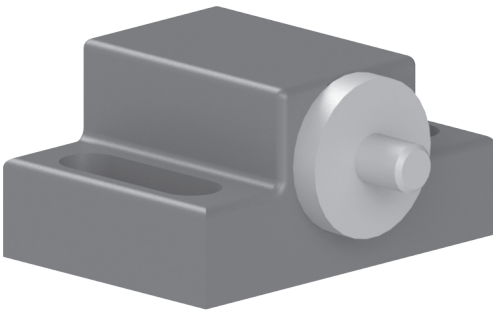

Reinforced polyamide
Poliammide rinforzata
Poliamida reforzada
Polyamide renforcé
Verstärktes Polyamid

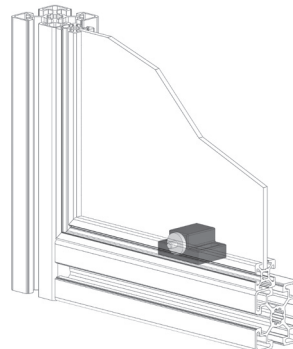
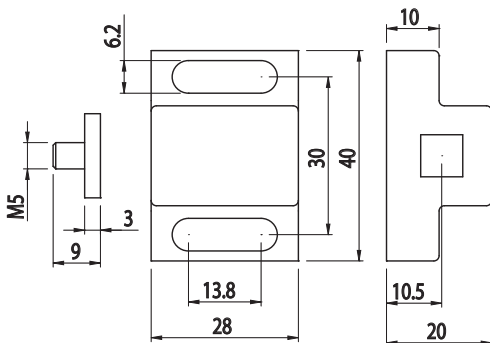



DOOR CLOSER

FERMAPORTE CON SFERA
TOPE DE PUERTA
FERMETURE PORTES
TÜRSTOPPER

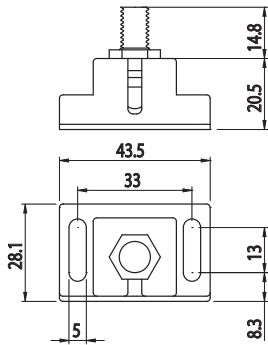
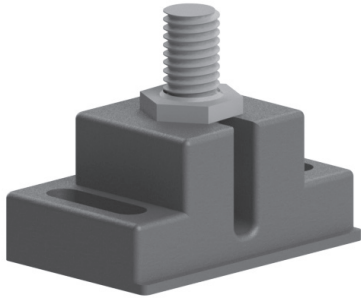

Cod	Note	g
084.519.007	M8 threaded pin included - Perno filettato M8 incluso - Perno roscado M8 incluido - Pivot fileté M8 fourni - Gewindestift M8 enthalten	35

Black polyamide

Poliammide nero
Poliamida color negro
Polyamide noir
Schwarzes Polyamid

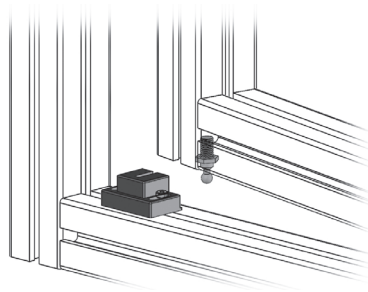

DOOR CLOSER

FERMAPORTE CON SFERA
TOPE DE PUERTA
FERMETURE PORTES
TÜRSTOPPER

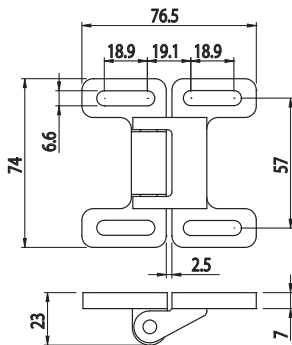
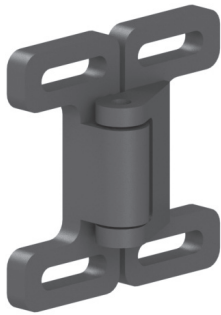

Cod	Note	g
084.519.006	Fastening with M6 screws, not included - Fissaggio con viti M6 non incluse - Fijación con tornillos M6, no incluidos - Montage avec vis M6, non fournies - Montage mit Schrauben M6, nicht enthalten	120

Black polyamide

Poliammide nero
Poliamida color negro
Polyamide noir
Schwarzes Polyamid

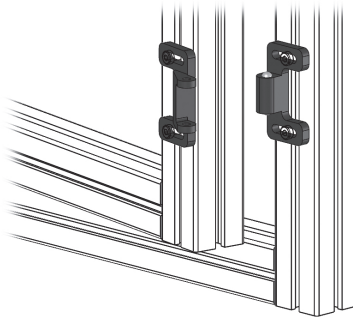

**DOOR CLOSER**

FERMAPORTE
TOPE DE PUERTA
FERMETURE PORTES
TÜRSTOPPER

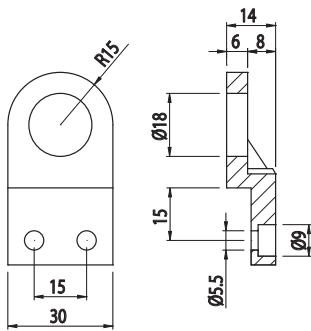

Cod	Note	g
084.522.002	For M18 magnet - Per magnete M18 - Para imán M18 - Pour aimant M18 - Für Magnet M18	11

Grey polyamide

Poliammide grigio
Poliamida color gris
Polyamide gris
Grau Polyamid

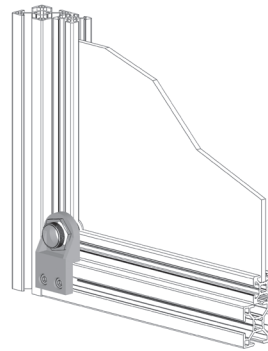
**DOOR CLOSER**

FERMAPORTE
TOPE DE PUERTA
FERMETURE PORTES
TÜRSTOPPER

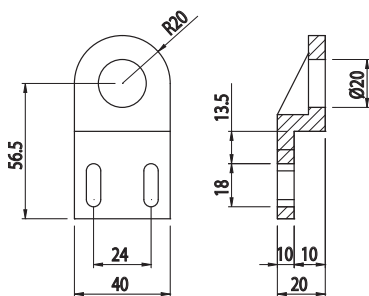

Cod	Note	g
084.522.001	For M18 magnet - Per magnete M18 - Para imán M18 - Pour aimant M18 - Für Magnet M18	27

Grey polyamide

Poliammide grigio
Poliamida color gris
Polyamide gris
Grau Polyamid

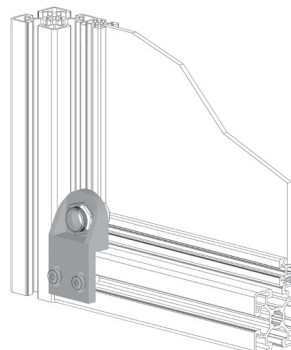



DOOR CLOSER

FERMAPORTE
TOPE DE PUERTA
FERMETURE PORTES
TÜRSTOPPER

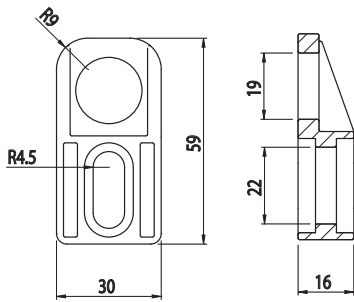

Cod	Note	g
084.522.003	For M18 magnet - Per magnete M18 - Para imán M18 - Pour aimant M18 - Für Magnet M18	12

Black polyamide

Poliammide nero
Poliamida color negro
Polyamide noir
Schwarzes Polyamid

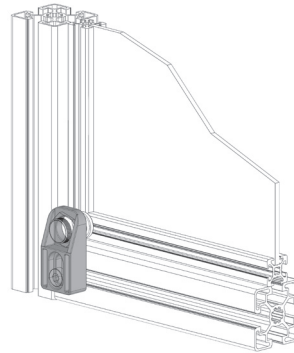

MAGNET

MAGNETE
IMÁN
AIMANT
MAGNET

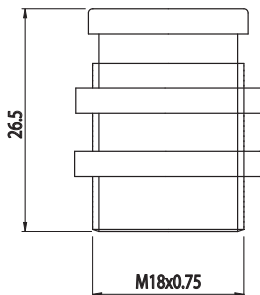
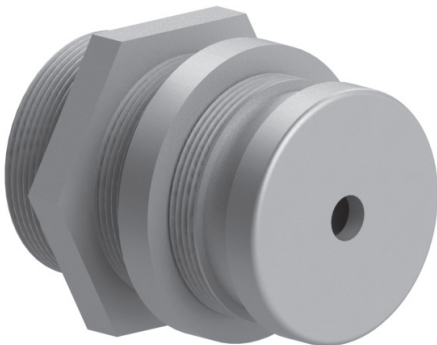

Cod	Note	g
084.523.001	Attractive force 70 N - Forza di attrazione 70 N - Fuerza de atracción 70 N - Force attractive 70 N - Anziehungskraft 70 N	52

Zinc plated steel

Acciaio zincato
Acero galvanizado
Acier zingué
Verzinkter Stahl

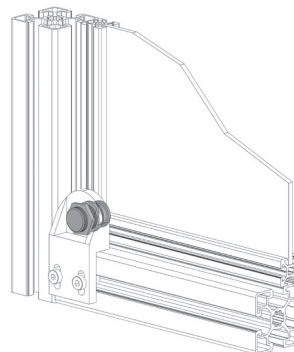

**DOOR CLOSER WITH MAGNET**

FERMAPORTE CON MAGNETE
TOPE DE PUERTA CON IMÁN
FERMETURE PORTES À AIMANT
TÜRSTOPPER MIT MAGNET

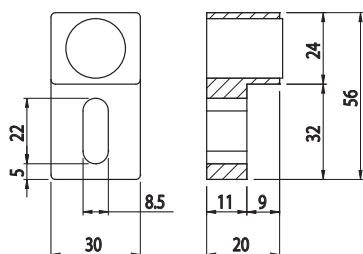
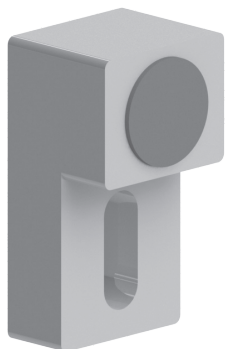

Cod	Note	g
084.524.001	Complete with magnet - Completo di magnete - Incluye imán - Doté d'aimant - Einschließlich Magnet	70

Sandblasted aluminium

Alluminio sabbato
Aluminio arenado
Aluminium sablé
Sandgestrahltes Aluminium

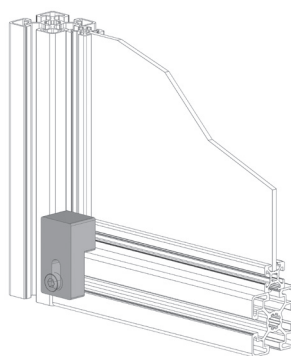
**CLIPS HOOKING**

AGGANCIO A CLIPS
ACOPLAMIENTO CON CLIPS
ACCROCHAGE AVEC CLIPS
CLIP BEFESTIGUNG

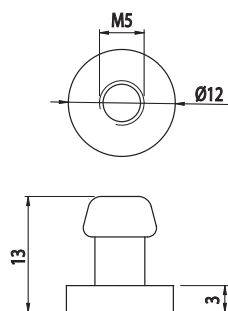

Cod	Note	g
084.523.003	Stop pin - Perno di riscontro - Perno de guía - Goupille de butée - Klemmnuss	5

Galvanised steel

Acciaio zincato
Acero galvanizado
Acier zingué
Verzinkter Stahl

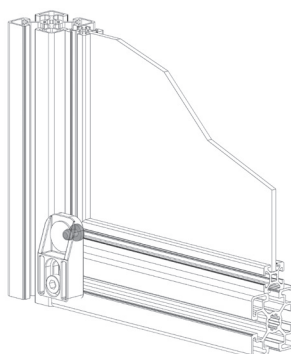



CLIPS HOOKING

AGGANCIO A CLIPS
ACOPLAMIENTO CON CLIPS
ACCROCHAGE AVEC CLIPS
CLIP BEFESTIGUNG

Cod	Note	g
084.523.002	Clips	4

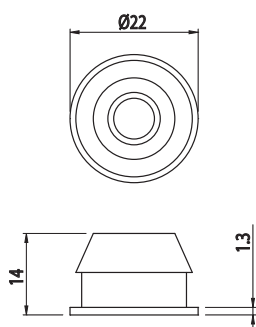
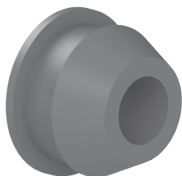

Thermoplastic rubber

Gomma termoplastica
Goma termoplástica
Caoutchouc thermoplastique
Thermoplastischer Gummi

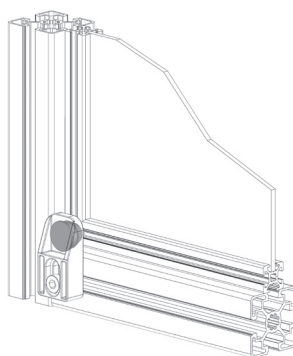

CABLE CLIP

BLOCCHETTO FERMACAVI
BLOQUE OCULTA-CABLES
EMBASE
KABELHALTERBLOCK

Cod	Note	g
084.510.013	Fastening with M5 screws, not included - Fissaggio con viti M5 non incluse - Fijación con tornillos M5, no incluidos - Fixation avec vis M5 non fournies - Befestigung mit Schrauben M5 (nicht im Lieferumfang enthalten)	2

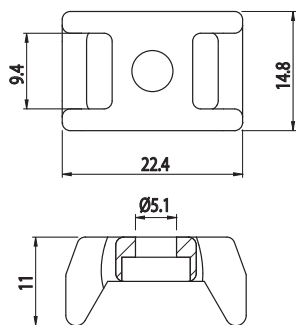

Grey polyamide

Poliammide grigio
Poliamida color gris
Polyamide gris
Grau Polyamid





CLIP CABLE BINDER
 BLOCCHETTO FERMACAVI
 BLOQUE DE FIJACIÓN CABLES
 BLOC FIDE CABLES
 CLIP-KABELBINDER

BH 105 50 BH 105 45 BH 105 40

Cod	Note	g
084.510.018	Clips	10

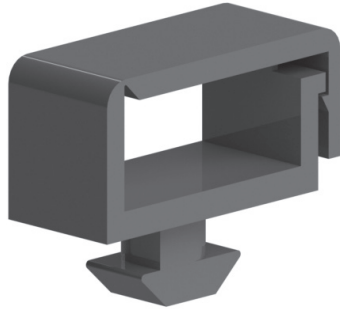

Black polyamide
 Poliammide nero
 Poliamida color negro
 Polyamide noir
 Schwarzes Polyamid

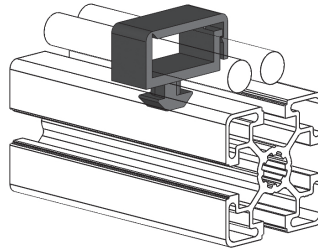
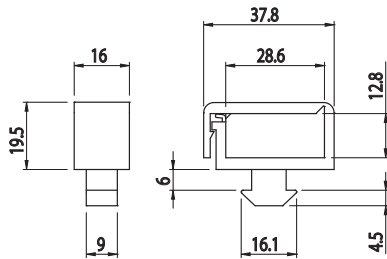

CLIP CABLE BINDER
 BLOCCHETTO FERMACAVI
 BLOQUE DE FIJACIÓN CABLES
 BLOC FIDE CABLES
 CLIP-KABELBINDER

BH 105 50 BH 105 45 BH 105 40

Cod	Note	g
084.510.019	Clips	13

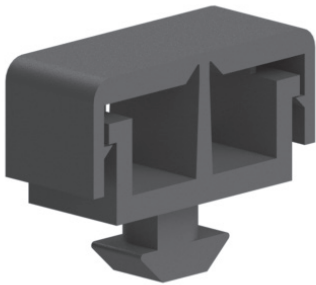

Black polyamide
 Poliammide nero
 Poliamida color negro
 Polyamide noir
 Schwarzes Polyamid

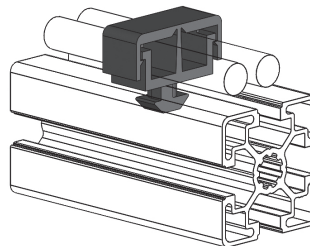
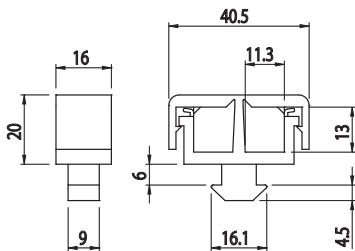



CLIP CABLE BINDER

BLOCCHETTO FERMACAVI
BLOQUE DE FIJACIÓN CABLES
BLOC FIDE CABLES
CLIP-KABELBINDER

BH 105 50 BH 105 45 BH 105 40

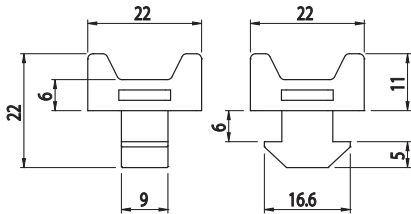

Cod	Note	g
084.510.021	Fasten with plastic tie - Fissaggio con fascetta - Fijar con brida de plastico - Fixation avec collier de serrage en plastique - Befestigung mit Kabelbinder	8

Black polyamide

Poliammide nero
Poliamida color negro
Polyamide noir
Schwarzes Polyamid

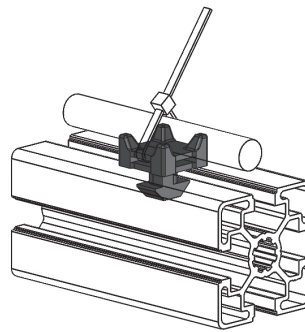

TOOL HANGER

PORTA UTENSILI
MOSQUETÓN DESLIZANTE
MOUSQUETON PORTE OUTILS
WERKZEUGGLEITER

BH 65 20

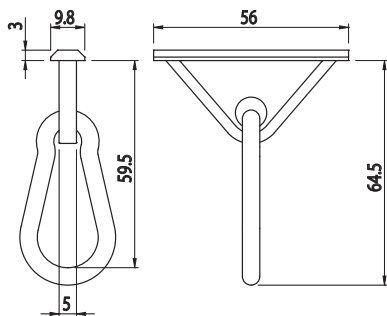

Cod	Note	g
084.535.004	Sliding - Scorrevole - Deslizante - Coulissant - Verschiebbar	32

Black polyamide

Poliammide nero
Poliamida color negro
Polyamide noir
Schwarzes Polyamid

Galvanised steel

Acciaio zincato
Acero galvanizado
Acier zingué
Verzinkter Stahl

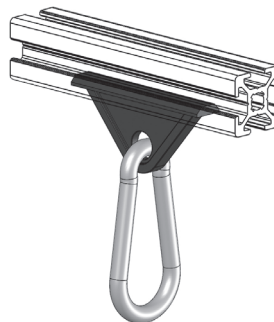

**TOOL HANGER**

PORTA UTENSILI
MOSQUETÓN DESLIZANTE
MOUSQUETON PORTE OUTILS
WERKZEUGGLEITER



Cod	Note	g
084.535.005	Sliding - Scorrevole - Deslizante - Coulissant - Verschiebbar	43

**Black polyamide**

Poliammide nero
Poliamida color negro
Polyamide noir
Schwarzes Polyamid

Galvanised steel

Acciaio zincato
Acero galvanizado
Acier zingué
Verzinkter Stahl

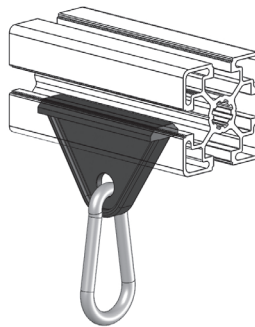
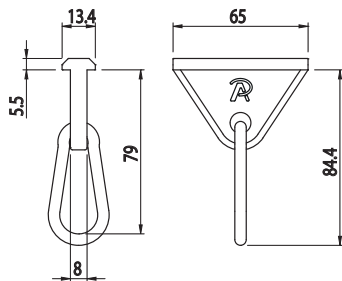
**TOOL HANGER**

PORTA UTENSILI
MOSQUETÓN DESLIZANTE
MOUSQUETON PORTE OUTILS
WERKZEUGGLEITER



Cod	Note	g
084.535.006	Sliding - Scorrevole - Deslizante - Coulissant - Verschiebbar	43

**Black polyamide**

Poliammide nero
Poliamida color negro
Polyamide noir
Schwarzes Polyamid

Galvanised steel

Acciaio zincato
Acero galvanizado
Acier zingué
Verzinkter Stahl

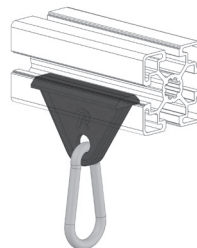
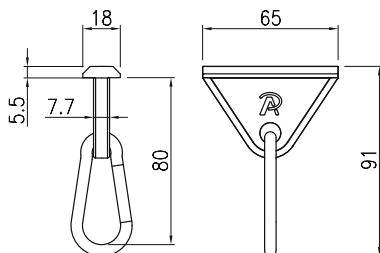

**GAS SPRING**

MOLLA A GAS
MUELLE DE GAS
RESSORT À GAZ
GASFEDER

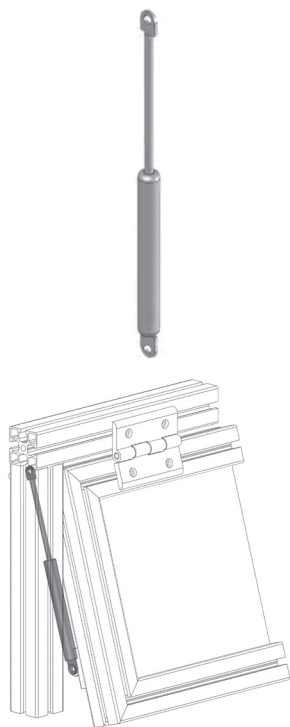

Cod	N	A	B	g
084.527.001	50	110	263	96
084.527.002	100	110	263	96
084.527.003	150	110	263	96
084.527.004	200	110	263	95
084.527.005	250	110	263	95
084.527.006	300	110	263	97
084.527.007	100	115	305	109
084.527.008	100	142	365	190
084.527.009	200	142	365	190
084.527.010	250	142	365	194
084.527.011	300	142	365	194
084.527.012	350	142	365	194
084.527.013	250	200	483	237
084.527.014	350	200	483	237

Other models available on request

A richiesta sono fornibili altri modelli

Bajo solicitud pueden suministrarse otros modelos

Autres modèles disponibles sur demande

Auf Anfrage können weitere Modelle geliefert werden

CALCOLO PER IL MONTAGGIO DI UNA MOLLA A GAS

GAS SPRING INSTALLATION CALCULATION / CÁLCULO PARA EL MONTAJE DE UN MUELLE DE GAS
CALCUL POUR LE MONTAGE D'UN RESSORT À GAZ / BERECHNUNG FÜR DIE MONTAGE EINER GASDRUCKFEDER

Definizione della forza di estensione F1 (N) a 20° C

Defining the extension force F1 (N) at 20° C
Definición de la fuerza de extensión F1 (N) a 20 °C
Définition de la force d'extension F1 (N) à 20°C
Definition der Dehnungskraft F1 (N) bei 20° C

$$F1 = \frac{G \times D}{b \times n} \times 13 \text{ (N)}$$

G = Peso del portellone in Kg

Weight of door in kg / Peso de la puerta en kg / Poids du battant en kg / Gewicht der Klappe in kg

L = Distanza fra il baricentro ed il punto di rotazione in mm

L = Distance between the centre of gravity and point of rotation in mm / Distancia entre el centro de gravedad y el punto de rotación en mm / Distance entre le barycentre et le point de rotation en mm / Abstand zwischen Schwerpunkt und Drehpunkt in mm

b = Braccio di leva utile della molla a gas in mm, portellone aperto

b = Effective lever arm of gas spring in mm with door open / Brazo de palanca útil del muelle de gas en mm, con la puerta abierta / Bras de levier utile du ressort à gaz en mm, battant ouvert / Nutzhebelarm der Gasdruckfeder in mm, geöffnete Klappe

13 = Coefficiente di conversione kg - N + riserva di sicurezza

13 = kg to N conversion factor + safety margin / Coeficiente de conversión kg - N + reserva de seguridad
Coefficient de conversion kg - N + marge de sécurité / Umrechnungsfaktor kg - N + Sicherheitsmarge

P = Fissaggio del portellone ca.2/3 L

P = Connection to door at approx. 2/3 of L / Fijación de la puerta en 2/3 L aprox. / Fixation du battant environ 2/3 L / Befestigung der Klappe ca.2/3 L

n = Numero delle molle a gas (Standard: n = 2)

n = Number of gas springs (2 x standard) / Número de muelles de gas (estándar: n = 2) / Nombre de ressorts à gaz (Standard : n = 2) / Anzahl der Gasdruckfedern (Standard: n = 2)

D = Braccio di leva utile della forza di gravità in mm, portellone aperto

D = Effective lever arm of force of gravity in mm with door open / Brazo de palanca útil de la fuerza de gravedad en mm, con la puerta abierta / Bras de levier utile de la force de gravité en mm, battant ouvert / Nutzhebelarm der Schwerkraft in mm, geöffnete Klappe

Esempio

Example / Ejemplo / Exemple / Beispiel

G = 30 kg, D = 400 mm, b = 200 mm, n = 2

$$F1 = \frac{30 \times 400}{200 \times 2} \times 13 = 390 \text{ N}$$

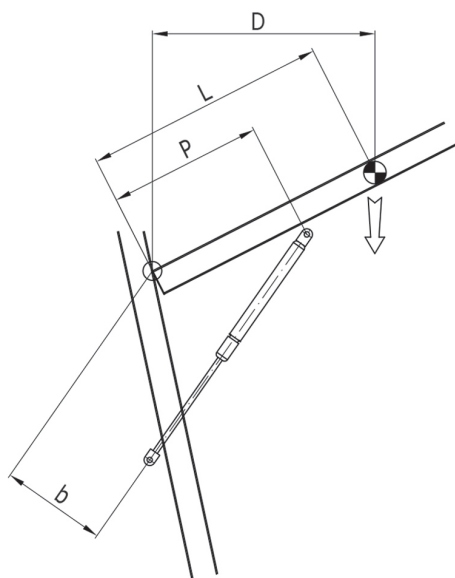
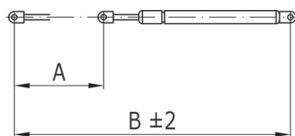

**GAS SPRING SUPPORT**

SUPPORTO PER MOLLA A GAS
SOPORTE PARA MUELLE DE GAS
SUPPORT POUR RESSORT À GAZ
HALTERUNG FÜR GASFEDER

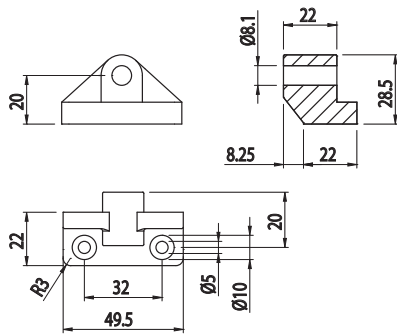
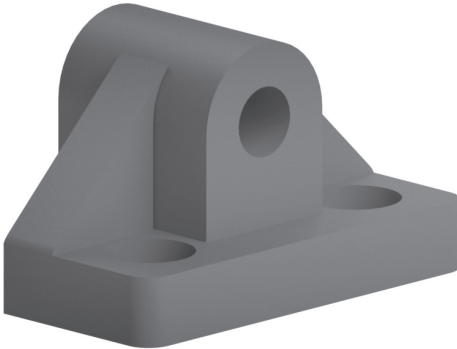

Cod	Note	g
084.528.001	Use with 084.528.002 - Usare con 084.528.002 - Utilizar con 084.528.002 - Utiliser avec 084.528.002 - Verwenden mit 084.528.002	21

Grey polyamide

Poliamide grigio
Poliamida color gris
Polyamide gris
Grau Polyamid

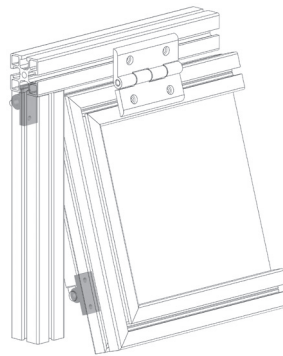
**SUPPORT PIN**

PERNO SUPPORTO
PERNO SOPORTE
PIVOT SUPPORT
AUFNAHMEBOLZEN

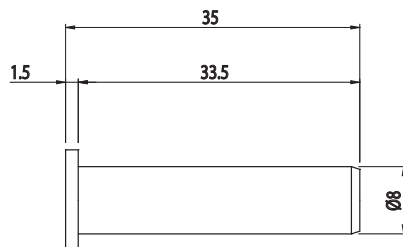
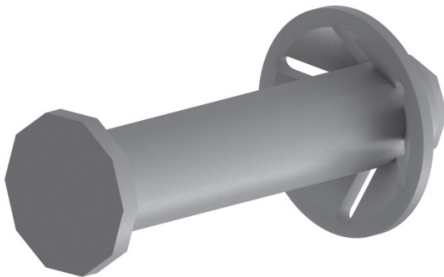

Cod	Note	g
084.528.002	For support 084.528.001 - Per supporto 084.528.001 - Para soporte 084.528.001 - Pour support 084.528.001 - Für Halterung 084.528.001	14

Galvanised steel

Acciaio zincato
Acero galvanizado
Acier zingué
Verzinkter Stahl

Washer included

Rondella inclusa
Arandela incluida
Rondelle fournie
Unterlegscheibe im Lieferumfang enthalten

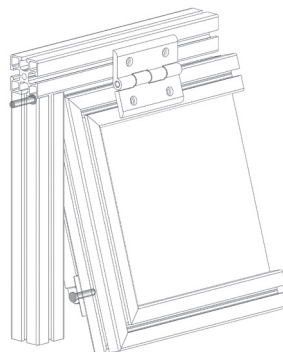



GAS SPRING SUPPORT

SUPPORTO PER MOLLA A GAS
SOPORTE PARA MUELLE DE GAS
SUPPORT POUR RESSORT À GAZ
HALTERUNG FÜR GASFEDER

Cod	Note	g
084.528.003	With Ø6 mm pin. - Con perno Ø6 - Con perno Ø6. - Avec axe Ø 6 - Mit Bolzen Ø6.	18

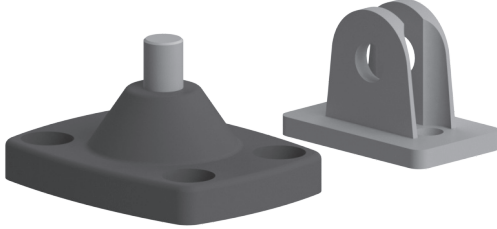

Grey polyamide and galvanised steel

Poliamide grigio e acciaio zincato
Poliamida color gris y acero galvanizado
Polyamide gris et acier zingué
Graues Polyamid und verzinkter Stahl

For small gas springs

Per piccole molle a gas
Para pequeñas muelles de gas
Pour petites ressorts à gaz
Für kleine Gasfedern

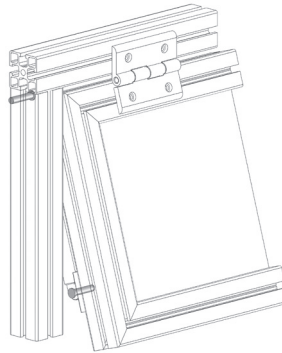
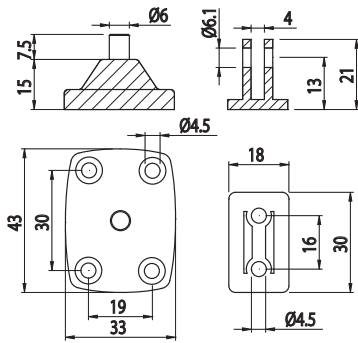

GAS SPRING SUPPORT

SUPPORTO PER MOLLA A GAS
SOPORTE PARA MUELLE DE GAS
SUPPORT POUR RESSORT À GAZ
HALTERUNG FÜR GASFEDER

Cod	Note	g
084.528.004	With Ø8 mm pin - Con perno Ø8 - Con perno Ø8 - Avec axe Ø 8 - Mit Bolzen Ø8	63

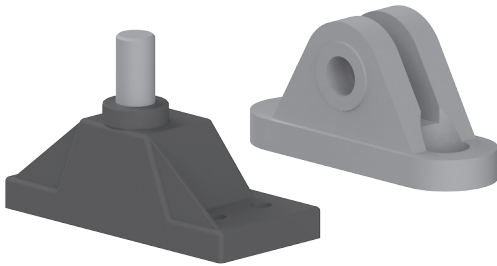

Grey polyamide and galvanised steel

Poliamide grigio e acciaio zincato
Poliamida color gris y acero galvanizado
Polyamide gris et acier zingué
Graues Polyamid und verzinkter Stahl

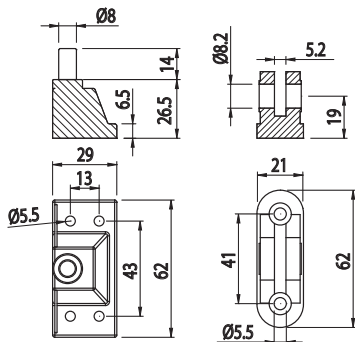

**SAFETY SWITCH**

INTERRUTTORE DI SICUREZZA
 INTERRUPTOR DE SEGURIDAD
 INTERRUPTEUR DE SÉCURITÉ
 SICHERHEITSSCHALTER



Cod	Note	g
084.601.001	Limit switch, 1 contact, NC - Finecorsa a 1 contatto NC - Final de carrera de 1 contacto NC - Fin de course à 1 contact NF - Endschalter mit 1 Kontakt NC	160

SAFETY SWITCH

INTERRUTTORE DI SICUREZZA
 INTERRUPTOR DE SEGURIDAD
 INTERRUPTEUR DE SÉCURITÉ
 SICHERHEITSSCHALTER



Cod	Note	g
084.601.002	Limit switch, 2 contacts, 1NC + 1NO - Finecorsa a 2 contatti 1NC + 1NA - Final de carrera de 2 contactos, 1 NC + 1 NA - Fin de course à 2 contacts 1 NF + 1 NO - Endschalter mit 2 Kontakten 1 NC + 1 NO	184



SAFETY MICROSWITCH

MICRO DI SICUREZZA
 MICROINTERRUPTOR DE SEGURIDAD
 MICRO-CONTACTEUR DE SÉCURITÉ
 SICHERHEITSMIKROSCHALTER



Cod	Note	g
084.601.003	Limit switch, 3 contacts, 2NC + 1NO - Finecorsa a 3 contatti 2NC + 1NA - Final de carrera de 3 contactos, 2 NC + 1 NA - Fin de course à 3 contacts 2 NF + 1 NO - Endschalter mit 3 Kontakten 2 NC + 1 NO	143

SAFETY MICROSWITCH

MICRO DI SICUREZZA
 MICROINTERRUPTOR DE SEGURIDAD
 MICRO-CONTACTEUR DE SÉCURITÉ
 SICHERHEITSMIKROSCHALTER

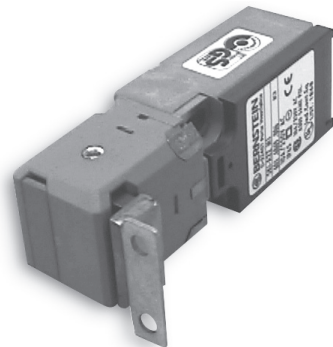

Cod	Note	g
084.602.001	Safety switch with 2 NC contacts - Interruttore di sicurezza a 2 contatti NC - Interruptor de seguridad de 2 contactos NC - Interrupteur de sécurité à 2 contacts NF - Sicherheitsschalter mit 2 Kontakten NC	131

**SAFETY ROTARY MICROSWITCH**

MICRO ROTATIVO DI SICUREZZA
 MICROINTERRUPTOR ROTATIVO DE SEGURIDAD
 MICRO-CONTACTEUR ROTATIF DE SÉCURITÉ
 SICHERHEITSMIKRODREHSCHALTER



Cod	Note	g
084.603.001	Limit switch for hinge axis with 2 contacts, 1NC+1NO - Finecorsa per assi cerniera con 2 contatti 1NC+1NA - Final de carrera para ejes bisagra con 2 contactos, 1 NC+1 NA - Fin de course pour axes charnière à 2 contacts 1 NF+1 NO - Endschalter für Scharnierachsen mit 2 Kontakten 1 NC+1 NO	96

PIN FOR SAFETY ROTARY MICROSWITCH

PERNO PER MICRO ROTATIVO
 PERNO PARA MICROINTERRUPTOR ROTATIVO
 PIVOT POUR MICRO-CONTACTEUR ROTATIF
 BOLZEN FÜR MIKRODREHSCHALTER



Cod	Note	g
084.531.001	For hinges 084.500.001 - 2 - 3 - 4 - 5 - 6 - Per cerniere 084.500.001 - 2 - 3 - 4 - 5 - 6 - Para bisagras 084.500.001 - 2 - 3 - 4 - 5 - 6 - Pour charnières 084.500.001 - 2 - 3 - 4 - 5 - 6 - Für Scharniere 084.500.001 - 2 - 3 - 4 - 5 - 6	91

Galvanised steel

Acciaio zincato
 Acero galvanizado
 Acier zingué
 Verzinkter Stahl

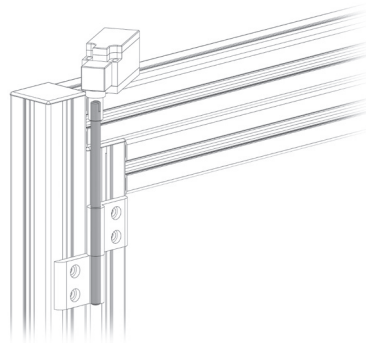
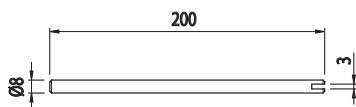



PIN FOR SAFETY ROTARY MICROSWITCH

PERNO PER MICRO ROTATIVO
PERNO PARA MICROINTERRUPTOR ROTATIVO
PIVOT POUR MICRO-CONTACTEUR ROTATIF
BOLZEN FÜR MIKRODREHSCHALTER

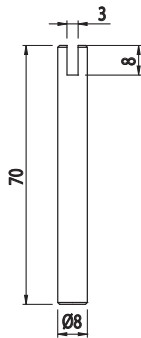

Cod	Note	g
084.533.002	Compatible with hinges 084.503.002 - 003 - Adatto alle cerniere 084.503.002 - 003 - Apto para las bisagras 084.503.002 - 003 - Adapté aux charnières 084.503.002 - 003 - Geeignet für Scharniere 084.503.002 - 003	27

Galvanised steel

Acciaio zincato
Acero galvanizado
Acier zingué
Verzinkter Stahl

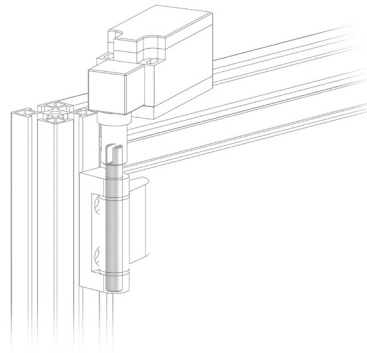

PIN FOR SAFETY ROTARY MICROSWITCH

PERNO PER MICRO ROTATIVO
PERNO PARA MICROINTERRUPTOR ROTATIVO
PIVOT POUR MICRO-CONTACTEUR ROTATIF
BOLZEN FÜR MIKRODREHSCHALTER

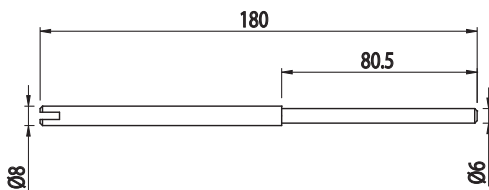

Cod	Note	g
084.608.001	Compatible with hinge 084.503.001 - Adatto alla cerniera 084.503.001 - Apto para la bisagra 084.503.001 - Adapté aux charnières 084.503.001 - Geeignet für Scharnier 084.503.001	65

Stainless steel

Acciaio inox
Acero inoxidable
Acier inox
Rostfreier Stahl

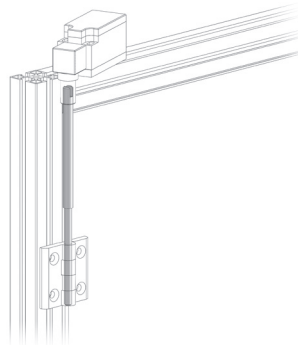

**PLATE FOR MICROSWITCH**

PIASTRINA PER MICRO
PLACA PARA MICROINTERRUPTOR
PLAQUETTE POUR MICRO-CONTACTEUR
PLATTE FÜR MIKROSCHALTER

Cod	Note	g
084.604.001	Plate, th. 6 mm - Piastrina sp. 6 mm - Placa gr. 6 mm - Plaquette ép. 6 mm - Platte Dicke 6 mm	24

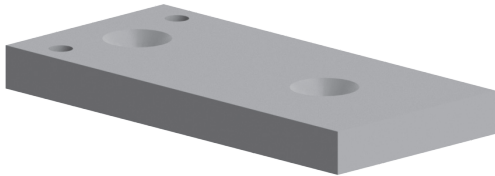
**Aluminium**

Alluminio
Aluminio
Aluminium
Aluminium

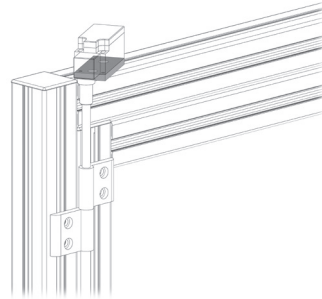
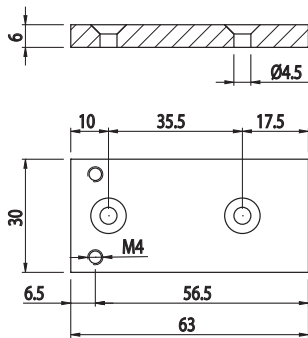
**PLATE FOR MICROSWITCH**

PIASTRINA PER MICRO
PLACA PARA MICROINTERRUPTOR
PLAQUETTE POUR MICRO-CONTACTEUR
PLATTE FÜR MIKROSCHALTER

Cod	Note	g
084.604.002	Plate, th. 10 mm - Piastrina sp. 10 mm - Placa gr. 10 mm - Plaquette ép. 10 mm - Platte Dicke 10 mm	52

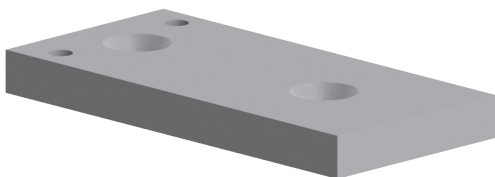
**Aluminium**

Alluminio
Aluminio
Aluminium
Aluminium

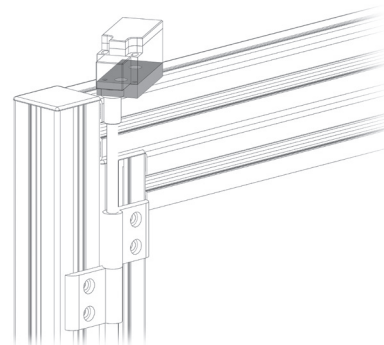
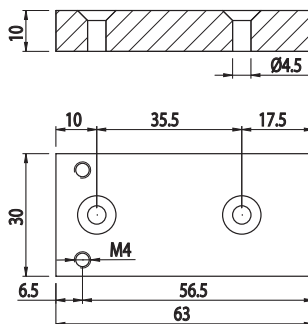



PLATE FOR MICROSWITCH

PIASTRINA PER MICRO
PLACA PARA MICROINTERRUPTOR
PLAQUETTE POUR MICRO-CONTACTEUR
PLATTE FÜR MIKROSCHALTER



Cod	Note	g
084.604.003	For external fastening - Per fissaggio esterno - Para fijación externa - Pour fixation externe - Für äußere Befestigung	91

Stainless steel

Acciaio inox
Acero inoxidable
Acier inox
Rostfreier Stahl

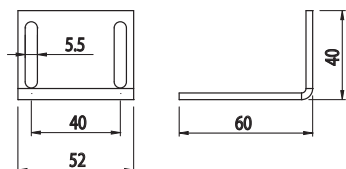

**LED PROFILE**

PROFILO LED
PERFIL LED
PROFILÉ LED
LED-PROFIL

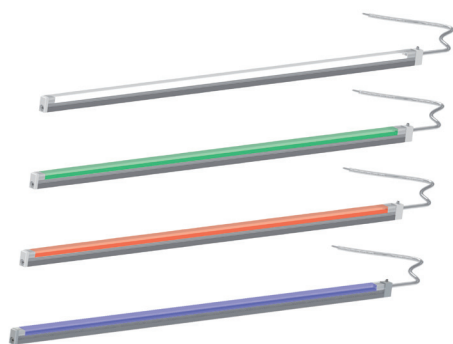
PATENTBH
8
30

Cod	V DC	W	Col (K)	L	g
700.015.4000.0250	24	3.75	□ 4000	250	65
700.015.4000.0500	24	7.5	□ 4000	480	120
700.015.4000.1000	24	15	□ 4000	980	230
700.015.4000.1990	24	30	□ 4000	1990	450
700.015.4000.2990	24	45	□ 4000	2990	680
700.015.4000.0250G	24	3.75	■	250	65
700.015.4000.0250R	24	3.75	■	250	65
700.015.4000.0250B	24	3,75	■	250	65
700.015.4000.0500G	24	7,5	■	480	120
700.015.4000.0500R	24	7,5	■	480	120
700.015.4000.0500B	24	7,5	■	480	120

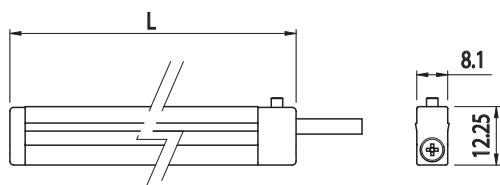
**LED PROFILE**

PROFILO LED
PERFIL LED
PROFILÉ LED
LED-PROFIL

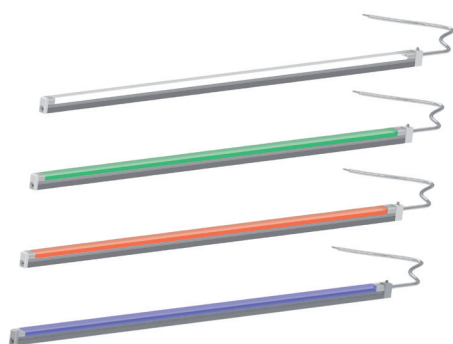
NEW**PATENT**BH
10
50BH
10
45

Cod	V DC	W	Col (K)	L	g
700.013.4000.0250	24	3,75	□ 4000	250	65
700.013.4000.0500	24	7,5	□ 4000	480	120
700.013.4000.1000	24	15	□ 4000	980	230
700.013.4000.1990	24	30	□ 4000	1990	450
700.013.4000.2990	24	45	□ 4000	2990	680
700.013.4000.0250G	24	3.75	■	250	65
700.013.4000.0250R	24	3.75	■	250	65
700.013.4000.0250B	24	3,75	■	250	65
700.013.4000.0500G	24	7,5	■	480	120
700.013.4000.0500R	24	7,5	■	480	120
700.013.4000.0500B	24	7,5	■	480	120

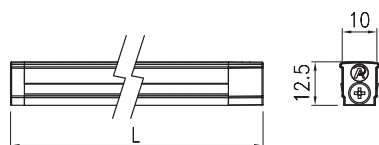



LED SIGNAL L.500MM

LED SEGNALAZIONE L.500MM
LED SEÑAL L.500MM
LED SIGNALISATION L.500MM
LED ANZEIGE L.500 MM

NEW

Cod	V	W	L	g
800.019.449	24	22,5	575,5	2000

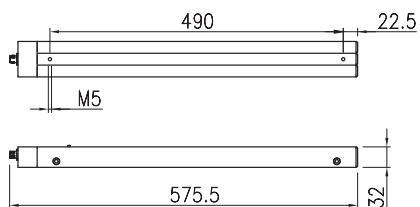
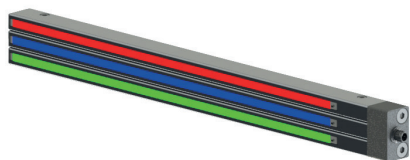

APPLICATION EXAMPLE

ESEMPIO APPLICATIVO / EJEMPLO APLICATIVO
EXEMPLE D'APPLICATION / ANWENDUNGSBEISPIEL

Authorized access
Accesso autorizzato
Acceso autorizado
Accès autorisé
Autorisierten Zugriff



Unauthorized access
Accesso non autorizzato
Acceso no autorizado
Accès non autorisé
Unbefugten Zugriff



Fully operational
Plenamente operativo / plenamente operativo
Plenement opérationnel/ Voll funktionsfähig



Non-operating
Non operativo / Inoperativo
Non opérationnel / Nicht betriebsbereit



Under maintenance
In manutenzione / En mantenimiento
En maintenance / Im Wartungsmodus

**POWER PACK**

ALIMENTATORE
ALIMENTADOR
ALIMENTATEUR
NETZTEIL

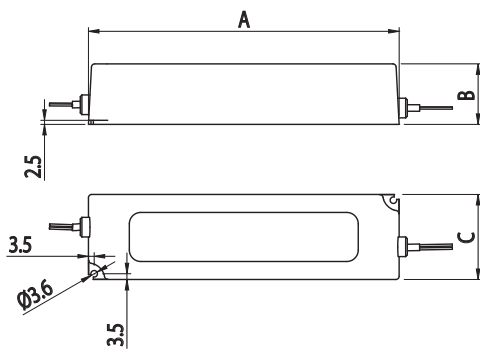

Cod	V	W	VAC	A	B	C	g	LED
700.024.020	24	20,20	90-264	118	26	35	0,22	700.013.4000.0250
								700.013.4000.0500
								700.013.4000.1000
								700.015.4000.0250
								700.015.4000.0500
700.024.060	24	60	90-264	162,5	32	42,50	0,40	700.015.4000.1990
								700.015.4000.2990
								700.015.4000.1990
								700.015.4000.2990

**MOUNTING INSTRUCTIONS**

ISTRUZIONI DI MONTAGGIO / INSTRUCCIONES DE INSTALACION
INSTRUCTIONS DE MONTAGE / MONTAGEANLEITUNGEN

Insert the lighting device inside the slot

Inserire l'apparecchio illuminante all'interno della cava / Insertar el LED en la ranura
Insérer le LED dans la rainure / Die LED Leiste in die Nut einsetzen

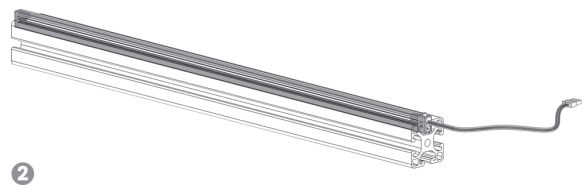
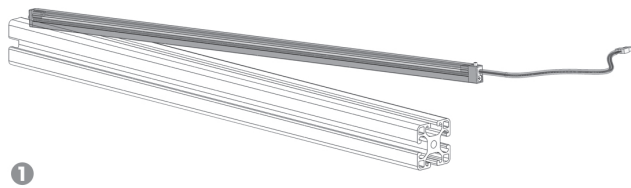
**Connect to a proper power supply**

Collegare ad un opportuno alimentatore / Conectar a una alimentacion apropiada
Connecter à une alimentation appropriée / Den angemessenen Trafo

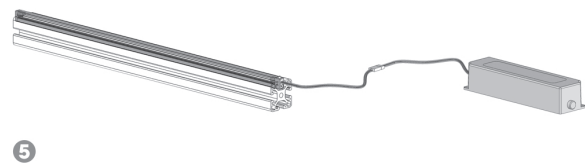



OPTICAL AND LIGHTING TECHNICAL INFORMATION

CARATTERISTICHE OTTICHE E ILLUMINOTECNICHE / CARACTERÍSTICAS ÓPTICAS Y LUMINOTECNICAS / CARACTÉRISTIQUES OPTIQUES ET ET DONNÉES D'ÉCLAIRAGE / OPTISCHE UND BELEUCHTUNGSTECHNISCHE MERKMALE

79 lm/W (1200 lm/m)

Luminous efficacy
Efficienza luminosa
Eficacia luminosa
Efficacité lumineuse
Lichtausbeute

120 led/m

Number of LEDs
Numero di led
Nombre de led
Número de LEDs
Anzahl an LEDs

CRI > 80

Colour Rendering Index
Indice di resa cromatica
Índice de reproducción cromática
Indice de rendu chromatique
Farbwiedergabeindex

L70(6K) > 248000 h

Service life
Durata di vita
Vida útil
Cycle de vie
Lebensdauer

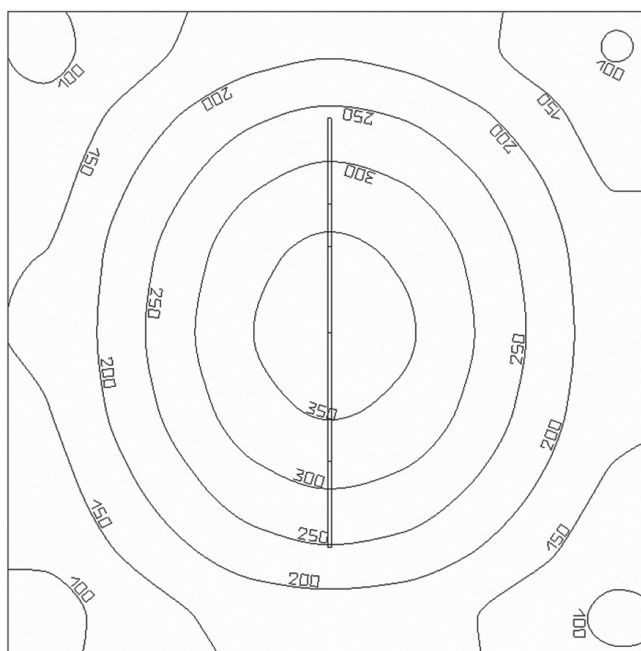

Photometry referred to a piece L=500
Fotometria riferita a uno spezzone L=500

ELECTRICAL SPECIFICATIONS

CARATTERISTICHE ELETTRICHE / CARACTERÍSTICAS ELÉCTRICAS / CARACTÉRISTIQUES ÉLECTRIQUES / ELEKTRISCHE EIGENSCHAFTEN

IP 55

Ingress Protection rating
Grado di protezione
Grado de protección
Indice de protection
Schutzart

III

Protection class
Classe di isolamento
Clase de aislamiento
Classe d'isolation
Schutzklasse

MECHANICAL CHARACTERISTICS

CARATTERISTICHE MECCANICHE / CARACTERÍSTICAS MECÁNICAS / CARACTÉRISTIQUES MÉCANIQUES / MECHANISCHE EIGENSCHAFTEN

6060 T6

Extruded aluminium body, alloy
Corpo in alluminio estruso, lega
Cuerpo de aluminio extruido, aleación
Corps en aluminium extrudé, alliage
Körper aus stranggepresstem Aluminium, Legierung

Extruded and sanitised PMMA

Covering
Copertura
Cubierta
Couverture
Abdeckung



FLAT SURFACE LIGHTING DIAGRAMS

GRAFICI DI ILLUMINAMENTO SU UNA SUPERFICIE PIANA / DIAGRAMAS DE ILUMINACIÓN SOBRE UNA SUPERFICIE PLANA
GRAPHIQUES D'ÉCLAIRAGE SUR UNE SURFACE PLATE / BELEUCHTUNGSDIAGRAMM AUF EINER EBENEN FLÄCHE

1 m long LED lighting device set at the centre of a 1.5 m x 1.5 m square surface

Lampada LED di lunghezza 1m posizionata al centro di un quadrato 1.5m x 1.5m
Luz LED de 1 m de longitud colocada en el centro de un cuadrado de 1,5 m x 1,5 m
Lampe à LED de 1 m de longueur positionnée au centre d'un carré de 1,5 m x 1,5 m
1 m lange, in der Mitte eines 1,5 m x 1,5 m großen Quadrats aufgestellte LED-Leiste

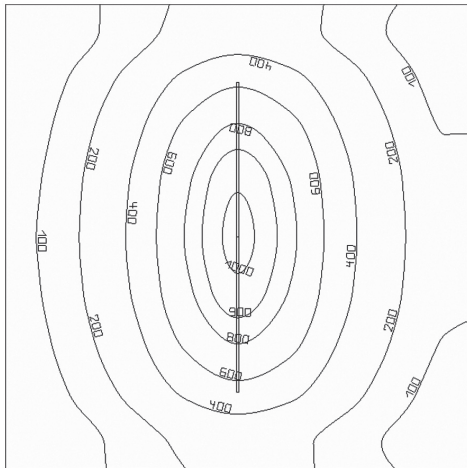

1500x1500x500 - 1000

0.50m

Distance from the illuminated surface

Distanza dal piano illuminato
Distancia desde el plano iluminado
Distance de la surface éclairée
Abstand von der beleuchteten Fläche

Em = 337 lx

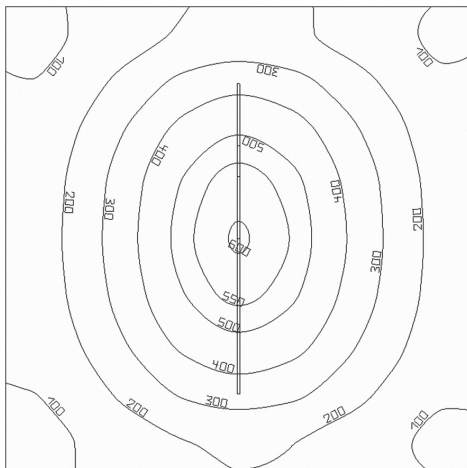

1500x1500x750 - 1000

0.75m

Distance from the illuminated surface

Distanza dal piano illuminato
Distancia desde el plano iluminado
Distance de la surface éclairée
Abstand von der beleuchteten Fläche

Em = 272 lx

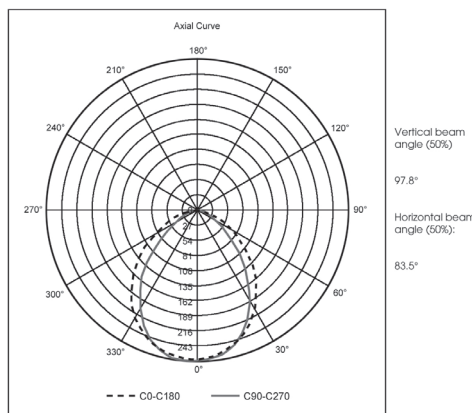

1500x1500x1000 - 1000

1m

Distance from the illuminated surface

Distanza dal piano illuminato
Distancia desde el plano iluminado
Distance de la surface éclairée
Abstand von der beleuchteten Fläche

Em = 214 lx



DRILLING TEMPLATE

MASCHERA FORATURA
PLANTILLA DE TALADRADO
GABARIT DE PERÇAGE
BOHRMASKE

BH
8
30

Cod	Note	g
084.818.013	Complete with screws - Completo di viti - Incluye tornillos - Doté de vis - Einschließlich Schrauben	70

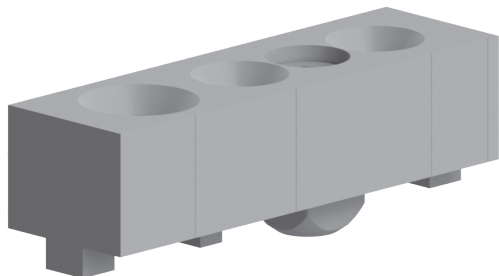

Aluminium

Alluminio
Aluminio
Aluminium
Aluminium

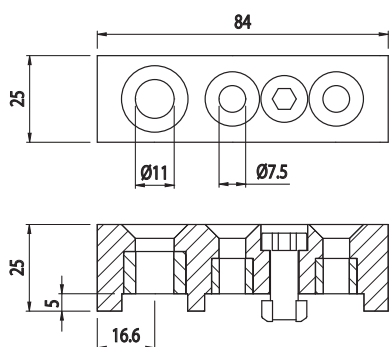

DRILLING TEMPLATE

MASCHERA FORATURA
PLANTILLA DE TALADRADO
GABARIT DE PERÇAGE
BOHRMASKE

BH
10
40

BH
10
50

Cod	Note	g
084.818.011	Complete with screws - Completo di viti - Incluye tornillos - Doté de vis - Einschließlich Schrauben	85

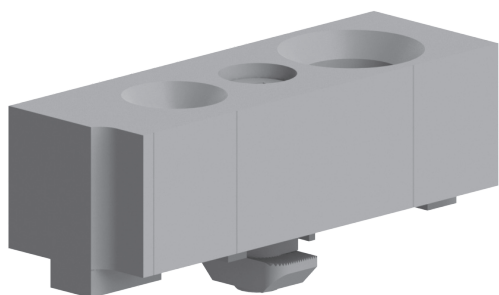

Aluminium

Alluminio
Aluminio
Aluminium
Aluminium

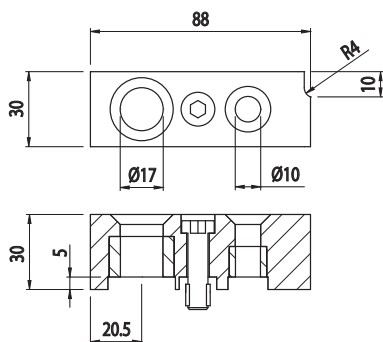

**DRILLING TEMPLATE**

MASCHERA FORATURA
PLANTILLA DE TALADRADO
GABARIT DE PERÇAGE
BOHRMASKE

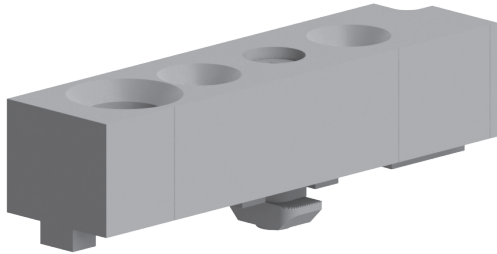
Cod	Note	g
084.818.012	Complete with screws - Completo di viti - Incluye tornillos - Doté de vis - Einschließlich Schrauben	85

Aluminium

Alluminio
Aluminio
Aluminium
Aluminium

**Ø5.5 MM BIT**

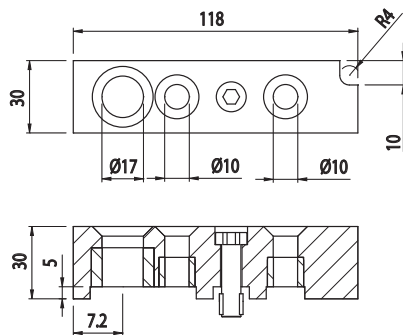
PUNTA Ø5,5
BROCA Ø5,5
FORET Ø 5,5
BOHREINSATZ Ø5,5



Cod	Note	g
084.818.005	Suitable for 6 mm slot profiles - Adatta a profili cava 6 - Apta para perfiles con ranura de 6 mm - Adaptée aux profilés rainure 6 - Geeignet für Profile mit Nut 6	20

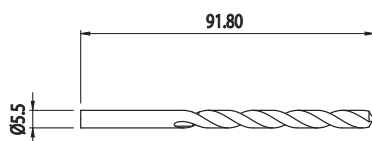



Ø7.5 MM BIT

PUNTA Ø7,5
BROCA Ø7,5
FORET Ø 7,5
BOHREINSATZ Ø7,5

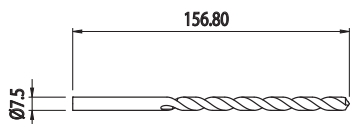

Cod	Note	g
084.818.006	Suitable for 8 mm slot profiles - Adatta a profili cava 8 - Apta para perfiles con ranura de 8 mm - Adaptée aux profilés rainure 8 - Geeignet für Profile mit Nut 8	53

Ø7 MM BIT

PUNTA Ø7
BROCA Ø7
FORET Ø 7
BOHREINSATZ Ø7

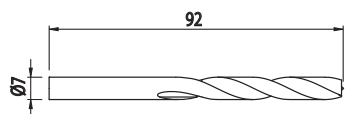

Cod	Note	g
084.818.007	Suitable for M5 bushings - Adatta alle boccole M5 - Apta para casquillos M5 - Adaptée aux douilles M5 - Geeignet für Buchsen M5	50

**Ø9 MM BIT**

PUNTA Ø9
 BROCA Ø9
 FORET Ø 9
 BOHREINSATZ Ø9

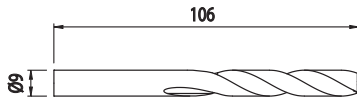

Cod	Note	g
084.818.008	Suitable for M6 bushings - Adatta alle boccole M6 - Apta para casquillos M6 - Adaptée aux douilles M6 - Geeignet für Buchsen M6	75

Ø11 MM BIT

PUNTA Ø11
 BROCA Ø11
 FORET Ø 11
 BOHREINSATZ Ø11

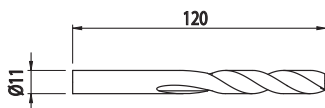

Cod	Note	g
084.818.009	Suitable for M8 bushings - Adatta alle boccole M8 - Apta para casquillos M8 - Adaptée aux douilles M8 - Geeignet für Buchsen M8	95



COUNTERBORE BIT

PUNTA PER LAMATURE
BROCA PARA AVELLANADO
FRAISE À LAMER
BOHREINSATZ FÜR SENKUNGEN

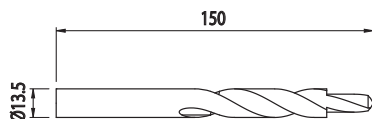

Cod	Note	g
084.818.003	For Ø9 - Ø13.5 mm counterbore - Per lamature Ø9 - Ø13,5 - Para avellanados Ø9 - Ø13,5 - Pour lamages Ø 9 - Ø 13,5 - Für Senkungen Ø9 - Ø13,5	120

SET OF ALLEN KEYS

SET DI CHIAVI ESAGONALI
SET DE LLAVES HEXAGONALES
JEU DE CLÉS ALLEN
SECHSKANTSCHLÜSSELSET

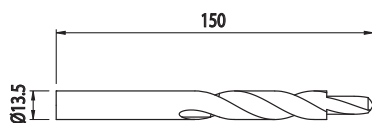

Cod	Note	g
084.818.010	Set of 2.5 - 6 mm wrenches - Set di chiavi 2,5 - 6 - Set de llaves 2,5-6 - Jeu de clés 2,5 - 6 - Schlüsselset 2,5 - 6	700

**HIGH-STRENGTH ADHESIVE**

COLLA AD ALTA RESISTENZA
PEGAMENTO DE ALTA RESISTENCIA
COLLE À HAUTE RÉSTISANCE
HOCHFESTER KLEBSTOFF



Cod	Note	g
084.818.004	High-strength adhesive for steel and aluminium - Colla ad alta resistenza per acciaio e alluminio - Pegamento de alta resistencia para acero y aluminio - Colle à haute résistance pour acier et aluminium - Hochfester Klebstoff für Stahl und Aluminium	70



DOORS WITH SAFETY SWITCH

PORTE CON INTERRUTTORE DI SICUREZZA
PUERTAS CON INTERRUPTOR DE SEGURIDAD PORTES
AVEC INTERRUPTEUR DE SÉCURITÉ TUREN MIT SI-
CHERHEITSSCHALTER

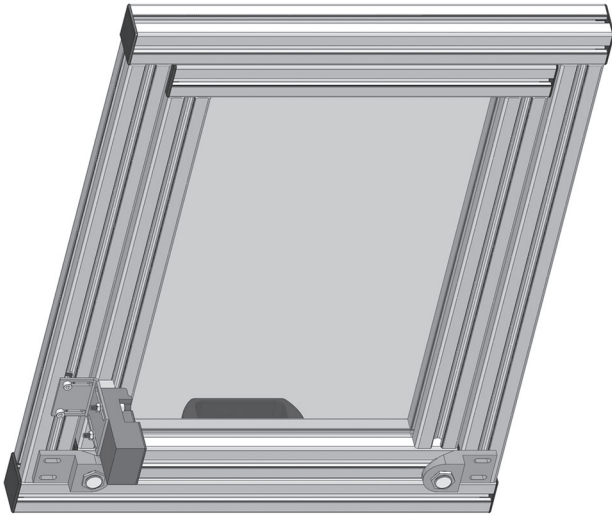

SPORTELO
LxH
L= A-7
H= B-10
P= L-90

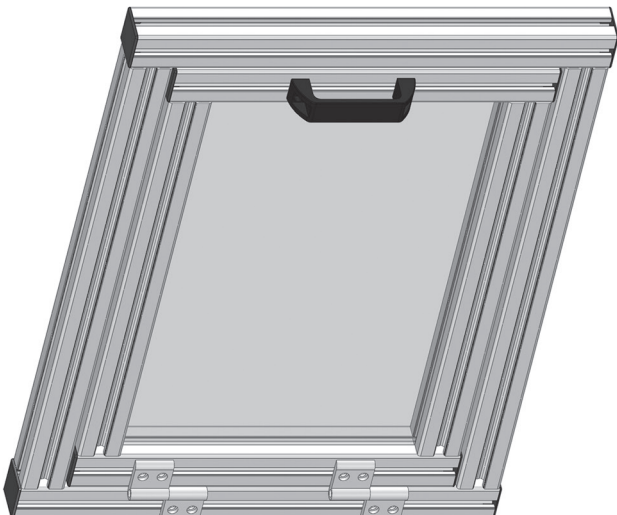
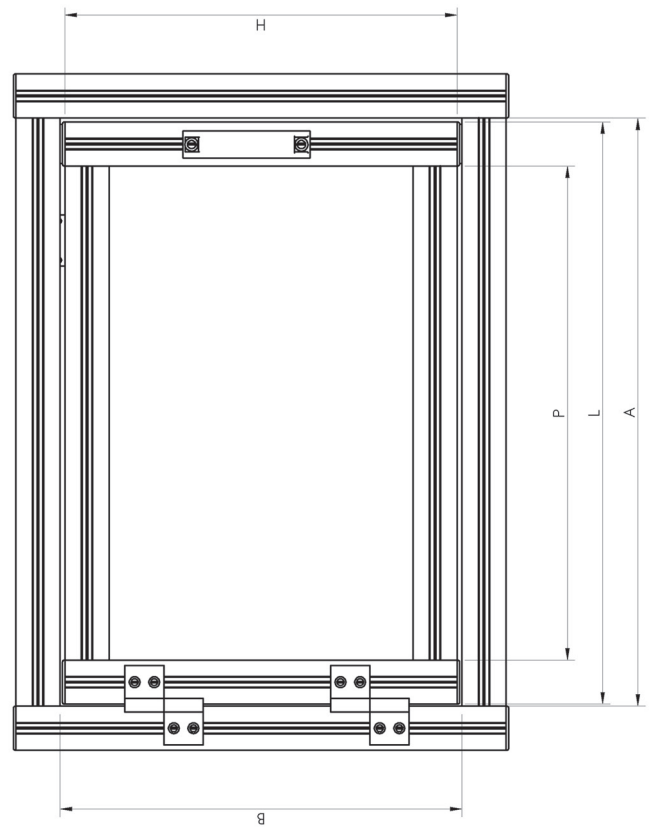



DOORS WITH SAFETY SWITCH

PORTE CON INTERRUPTORE DI SICUREZZA
 PUERTAS CON INTERRUPTOR DE SEGURIDAD PORTES
 AVEC INTERRUPTEUR DE SÉCURITÉ TÜREN MIT SI-
 CHERHEITSSCHALTER

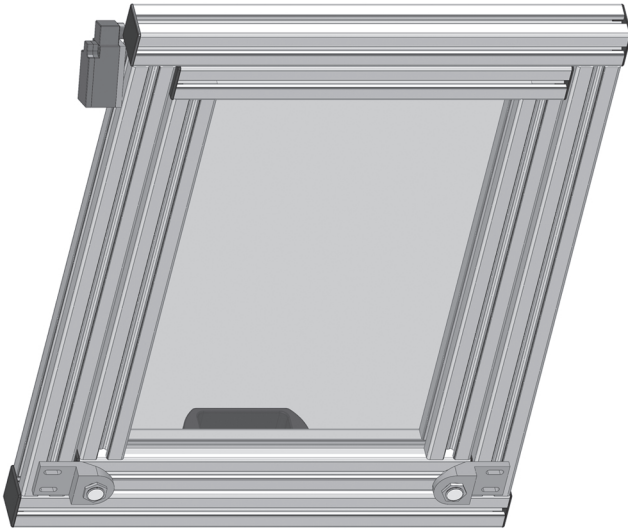

SPORTELO
LxH
L= A-7
H= B-10
P= L-90

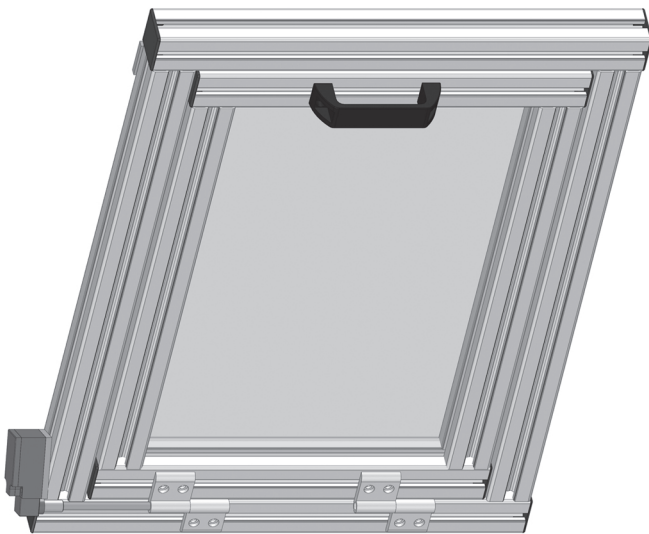
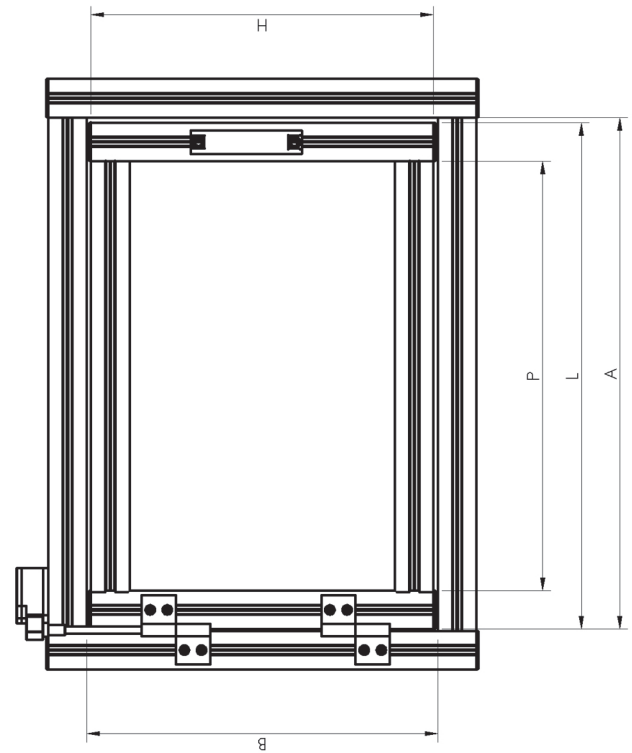



SLIDING DOORS WITH MULTIPURPOSE PROFILE

PORTE SCORREVOLI CON PROFILO MULTIUSO
PUERTAS CORREDIZAS CON PERFIL MULTIUSO PORTES
COULISSANTES AVEC PROFILÉ POL YVALENT SCHIEBETU-
REN MIT MEHRZWECKPROFIL

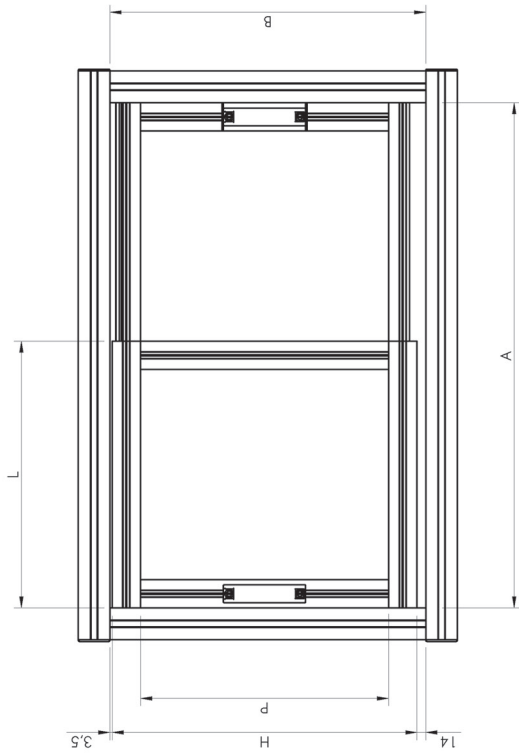

SPORTELLINO
LxH
L= (A/2) + 22,5
H= B-17,5
P= H-90

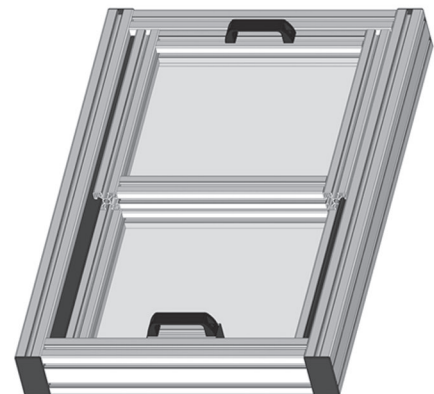
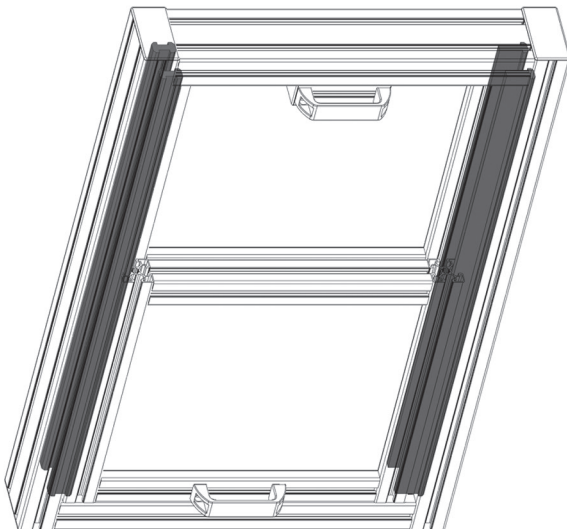
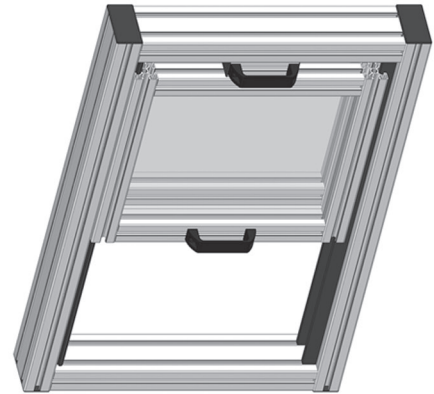
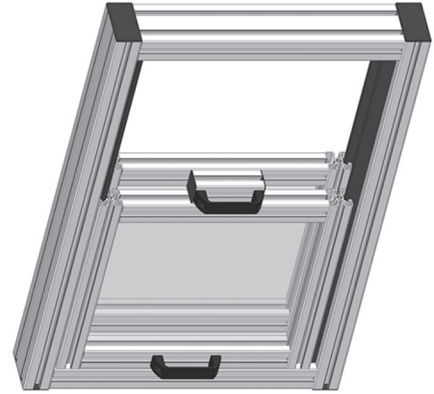



INDEX

INDICE
ÍNDICE
INDEX
INDEX

CODE	PAGE	CODE	PAGE	CODE	PAGE
008VEKA103	181	084.111.004	17	084.201.066G	32
008VEKA111	181	084.112.001	55	084.201.067	41
008VEKA115	181	084.112.002	56	084.201.067G	41
013.100.030	211	084.113.001	31	084.201.068	50
013.100.031	211	084.113.002	31	084.201.068G	50
013.100.032	212	084.113.003	32	084.201.069	55
013.100.033	212	084.201.038	37	084.201.069G	55
013.506.008	201	084.201.038	37	084.201.070	56
013.506.009	200	084.201.038	38	084.201.070G	56
013.506.010A	200	084.201.038	38	084.201.071	39
013.506.010A	201	084.201.038	39	084.201.071G	39
013.506.010G	200	084.201.038G	37	084.201.074	44
013.506.010G	201	084.201.038G	37	084.201.074G	44
030LEX	179	084.201.038G	38	084.201.075	17
031LEX	179	084.201.038G	38	084.201.075G	17
032LEX	179	084.201.038G	39	084.201.079	60
034LEX	179	084.201.039	40	084.201.096	59
035LEX	179	084.201.039	41	084.201.097	59
059.032.029	207	084.201.039G	40	084.201.099	61
062LEX	180	084.201.039G	41	084.202.002	84
084.101.053	60	084.201.040	42	084.202.002N	84
084.101.054	60	084.201.040	42	084.202.005	84
084.101.055	61	084.201.040	43	084.202.005N	84
084.101.056	61	084.201.040	43	084.202.006	85
084.101.065	62	084.201.040	44	084.202.007	86
084.101.078	60	084.201.040G	42	084.202.008	86
084.101.079	60	084.201.040G	42	084.202.009	85
084.101.092	59	084.201.040G	43	084.203.010	66
084.101.093	59	084.201.040G	43	084.203.010N	66
084.101.097	59	084.201.040G	44	084.203.023	65
084.101.098	59	084.201.041	23	084.203.024	65
084.101.099	61	084.201.041	23	084.203.024	177
084.101.100	61	084.201.041	24	084.203.026	66
084.104.003	55	084.201.041	24	084.203.027	66
084.105.004	37	084.201.041G	23	084.206.001	121
084.105.005	42	084.201.041G	23	084.206.001	121
084.105.006	40	084.201.041G	24	084.206.001G	121
084.105.007	40	084.201.041G	24	084.206.001G	121
084.105.008	41	084.201.042	25	084.206.002	122
084.105.009	43	084.201.042	26	084.206.002	122
084.105.010	37	084.201.042G	25	084.206.002G	122
084.105.011	38	084.201.042G	26	084.206.002G	122
084.105.012	39	084.201.052	40	084.206.003	128
084.105.013	44	084.201.052G	40	084.206.003	129
084.105.014	42	084.201.053	60	084.206.003	129
084.105.015	38	084.201.055	49	084.206.003	130
084.105.016	43	084.201.055G	49	084.206.003G	128
084.105.017	44	084.201.056	49	084.206.003G	129
084.105.018	39	084.201.056G	49	084.206.003G	129
084.105.019	41	084.201.057	26	084.206.003G	130
084.105.020	45	084.201.057	27	084.206.005	132
084.107.002	23	084.201.057G	26	084.206.005	132
084.107.003	25	084.201.057G	27	084.206.005	133
084.107.004	26	084.201.059	61	084.206.005	133
084.107.005	25	084.201.061	17	084.206.006	134
084.107.006	23	084.201.061G	17	084.206.006	134
084.107.007	27	084.201.062	18	084.206.007	118
084.107.008	24	084.201.062G	18	084.206.007G	118
084.107.009	24	084.201.063	25	084.206.008	119
084.107.010	26	084.201.063G	25	084.206.008	119
084.109.001	49	084.201.064	31	084.206.008G	119
084.109.002	49	084.201.064G	31	084.206.008G	119
084.109.003	50	084.201.065	31	084.206.009	126
084.111.001	17	084.201.065G	31	084.206.009	126
084.111.002	18	084.201.066	32	084.206.010	136

CODE	PAGE	CODE	PAGE	CODE	PAGE
084.206.010	136	084.302.061	73	084.305.040	126
084.206.011	131	084.302.062	74	084.305.040T	126
084.206.011	131	084.302.063	74	084.305.041	121
084.206.012	137	084.302.064	74	084.305.042	135
084.206.012	137	084.302.065	75	084.305.043	135
084.207.003	154	084.302.066	75	084.305.044	123
084.207.003	154	084.302.067	75	084.305.045	131
084.207.003	156	084.302.069	76	084.305.045T	131
084.207.004	159	084.302.070	76	084.305.047	136
084.301.001	67	084.302.071	76	084.305.047T	136
084.301.002	67	084.302.072	76	084.305.049	137
084.301.003	67	084.302.081	78	084.305.049T	137
084.301.004	67	084.302.082	78	084.305.050	116
084.301.005	67	084.302.083	78	084.305.051	117
084.301.006	67	084.302.084	78	084.305.052	117
084.301.007	67	084.302.095	75	084.305.054	125
084.301.008	67	084.302.096	75	084.305.056	140
084.301.009	67	084.302.097	75	084.305.057	140
084.301.010	67	084.302.098	75	084.305.058	125
084.301.011	67	084.302.099	77	084.305.059	122
084.301.012	67	084.302.100	77	084.305.060	123
084.301.013	67	084.302.101	77	084.306.008	88
084.301.018	71	084.302.102	77	084.306.009	88
084.301.019	71	084.302.103	77	084.306.013	90
084.301.020	71	084.302.115	78	084.306.014	87
084.301.021	71	084.302.116	78	084.306.015	87
084.301.024	69	084.302.117	78	084.306.017	89
084.301.025	68	084.302.118	78	084.306.018	89
084.301.026	68	084.302.119	77	084.307.024	98
084.301.027	68	084.302.120	77	084.307.025	98
084.301.028	68	084.302.121	77	084.307.030	116
084.301.029	68	084.302.122	77	084.307.031	103
084.301.030	68	084.302.127	79	084.307.032	104
084.301.031	68	084.302.128	79	084.307.036	102
084.301.032	68	084.303.004	82	084.307.037	97
084.301.033	68	084.303.007	82	084.307.039	90
084.301.035	67	084.303.008	83	084.307.040	91
084.301.036	67	084.305.001	121	084.307.041	91
084.301.037	70	084.305.002	122	084.307.042	92
084.301.038	67	084.305.003	128	084.307.043	92
084.301.039	69	084.305.003T	129	084.307.044	93
084.301.040	69	084.305.006	118	084.307.045	93
084.301.041	70	084.305.007	120	084.307.046	94
084.301.042	70	084.305.008	120	084.307.047	94
084.301.043	70	084.305.009	124	084.307.048	95
084.301.044	70	084.305.009T	124	084.307.049	95
084.301.045	71	084.305.010	119	084.307.050	96
084.301.046	72	084.305.016	139	084.307.051	97
084.301.047	72	084.305.021	130	084.307.052	102
084.301.054	67	084.305.022	128	084.307.053	103
084.301.079	69	084.305.024	127	084.308.001	113
084.302.021	73	084.305.024T	127	084.308.002	114
084.302.022	73	084.305.026	129	084.308.003	113
084.302.023	73	084.305.026T	130	084.308.004	114
084.302.024	73	084.305.028	133	084.308.006	115
084.302.025	74	084.305.028T	133	084.308.007	115
084.302.026	74	084.305.030	134	084.310.013	108
084.302.027	74	084.305.032	118	084.310.014	109
084.302.028	74	084.305.033	132	084.310.014G	109
084.302.029	75	084.305.033T	132	084.310.015	109
084.302.036	79	084.305.034	134	084.310.015G	109
084.302.043	76	084.305.036	119	084.310.020	105
084.302.044	76	084.305.037	138	084.310.021	105
084.302.045	76	084.305.038	138	084.310.022	106
084.302.046	76	084.305.039	139	084.310.023	106

CODE	PAGE	CODE	PAGE	CODE	PAGE
084.310.023G	106	084.408.001	145	084.506.006PA	207
084.310.024	107	084.408.002	149	084.506.006R	208
084.310.024G	107	084.408.003	145	084.506.007G	204
084.310.027	107	084.409.001	148	084.506.007GR	205
084.310.029	108	084.409.002	156	084.506.007N	203
084.311.011	112	084.409.003	156	084.506.007NR	204
084.311.012	112	084.409.004	154	084.506.008	202
084.311.016	110	084.409.005	154	084.506.009A	208
084.311.019	111	084.409.006	146	084.506.009B	209
084.311.020	111	084.409.007	146	084.506.009PA	209
084.311.021	110	084.409.008	147	084.506.011	201
084.312.003	80	084.409.009	158	084.507.001	168
084.312.004	80	084.409.010	158	084.509.001	168
084.312.005	81	084.409.011	157	084.509.002	169
084.312.006	81	084.409.012	159	084.509.003	169
084.312.007	81	084.409.013	157	084.510.001	170
084.312.014	104	084.409.014	155	084.510.002	170
084.401.001	150	084.409.015	147	084.510.003	170
084.401.002	150	084.409.016	148	084.510.004	170
084.401.003	150	084.409.018	155	084.510.009	171
084.401.004	150	084.410.003	153	084.510.010	171
084.402.001	151	084.410.006	153	084.510.011	171
084.402.002	151	084.500.003	186	084.510.012	171
084.402.003	151	084.500.006	188	084.510.013	218
084.402.004	151	084.500.009	189	084.510.017	172
084.402.005	151	084.500.010	192	084.510.018	219
084.402.006	151	084.500.011	192	084.510.019	219
084.402.008	151	084.500.012	191	084.510.020	172
084.403.001	152	084.500.015	187	084.510.021	220
084.403.002	152	084.500.016	186	084.512.003	176
084.403.003	152	084.500.017	188	084.512.003	176
084.403.004	152	084.500.018	187	084.512.004	176
084.404.001	161	084.500.020	190	084.512.006	176
084.404.002	164	084.500.020.	190	084.512.006G	176
084.404.003	162	084.500.021	191	084.512.010	178
084.404.004	164	084.500.023	189	084.512.030	177
084.404.005	165	084.501.008	195	084.512.030G	177
084.404.006	161	084.501.009	197	084.512.056	176
084.404.007	163	084.501.010	198	084.512.056G	176
084.404.008	162	084.501.011	195	084.514.012	175
084.404.009	165	084.501.013	196	084.514.013	174
084.405.001	141	084.501.014	197	084.514.014	174
084.405.004	141	084.501.015	198	084.514.016	175
084.405.005	141	084.501.016	199	084.517.001	210
084.405.006	143	084.501.017	194	084.518.002	210
084.405.007	141	084.501.019	193	084.519.001	211
084.405.010	141	084.501.020	193	084.519.002	212
084.405.011	141	084.501.021	196	084.519.003	173
084.405.013	141	084.502.003	184	084.519.004	173
084.405.015	141	084.502.005	184	084.519.006	214
084.405.016	141	084.502.006	183	084.519.007	214
084.405.017	141	084.503.001	183	084.519.008	213
084.405.018	141	084.503.002	185	084.522.001	215
084.405.019	141	084.503.003	185	084.522.002	215
084.405.020	141	084.504.001	200	084.522.003	216
084.405.021	143	084.504.002	200	084.523.001	216
084.405.022	143	084.504.003	200	084.523.002	218
084.405.023	141	084.506.003	203	084.523.003	217
084.405.024	143	084.506.005A	202	084.524.001	217
084.405.025	143	084.506.005B	202	084.525.001	213
084.405.026	143	084.506.005N	202	084.527.001	222
084.405.027	141	084.506.006	206	084.527.002	222
084.406.001	144	084.506.006	206	084.527.003	222
084.407.003	166	084.506.006G	206	084.527.004	222
084.407.010	167	084.506.006G	206	084.527.005	222

CODE	PAGE	CODE	PAGE	CODE	PAGE
084.527.006	222	700.013.4000.0250R	231		
084.527.007	222	700.013.4000.0500	231		
084.527.008	222	700.013.4000.0500B	231		
084.527.009	222	700.013.4000.0500G	231		
084.527.010	222	700.013.4000.0500R	231		
084.527.011	222	700.013.4000.1000	231		
084.527.012	222	700.013.4000.1990	231		
084.527.013	222	700.013.4000.2990	231		
084.527.014	222	700.015.4000.0250	231		
084.528.001	223	700.015.4000.0250B	231		
084.528.002	223	700.015.4000.0250G	231		
084.528.003	224	700.015.4000.0250R	231		
084.528.004	224	700.015.4000.0500	231		
084.531.001	227	700.015.4000.0500B	231		
084.533.002	228	700.015.4000.0500G	231		
084.535.004	220	700.015.4000.0500R	231		
084.535.005	221	700.015.4000.1000	231		
084.535.006	221	700.015.4000.1990	231		
084.536.001	142	700.015.4000.2990	231		
084.538.001	179	700.024.020	233		
084.538.002	179	700.024.060	233		
084.601.001	225	800.019.449	232		
084.601.002	225	5004A/3170	176		
084.601.003	226	DILITE3	180		
084.602.001	226	RETE 11x66	182		
084.603.001	227	RETE 11x66 INOX	182		
084.604.001	229	RETE 40X40X4	182		
084.604.002	229	RETE TEC 1003	182		
084.604.003	230	STR3MM	181		
084.608.001	228	STR4MM	181		
084.710.001	100	STR5MM	181		
084.710.002	99				
084.710.003	100				
084.710.004	99				
084.710.006G	101				
084.710.006N	101				
084.710.006ZN	101				
084.710.007G	101				
084.710.007N	101				
084.710.007ZN	101				
084.710.008G	101				
084.710.008N	101				
084.710.008ZN	101				
084.710.009G	101				
084.710.009N	101				
084.710.009ZN	101				
084.818.003	240				
084.818.004	241				
084.818.005	237				
084.818.006	238				
084.818.007	238				
084.818.008	239				
084.818.009	239				
084.818.010	240				
084.818.011	236				
084.818.012	237				
084.818.013	236				
511.011.000B	160				
511.011.000G	160				
511.011.000R	160				
511.011.000V	160				
670.001.000	182				
700.013.4000.0250	231				
700.013.4000.0250B	231				
700.013.4000.0250G	231				





Progetto grafico e impaginazione Sicoservice, Mondovì (CN)
Finito di stampare nel mese di febbraio 2024
presso tipografia San Martino, San Martino in Rio (RE)

BH LINE
ED.16

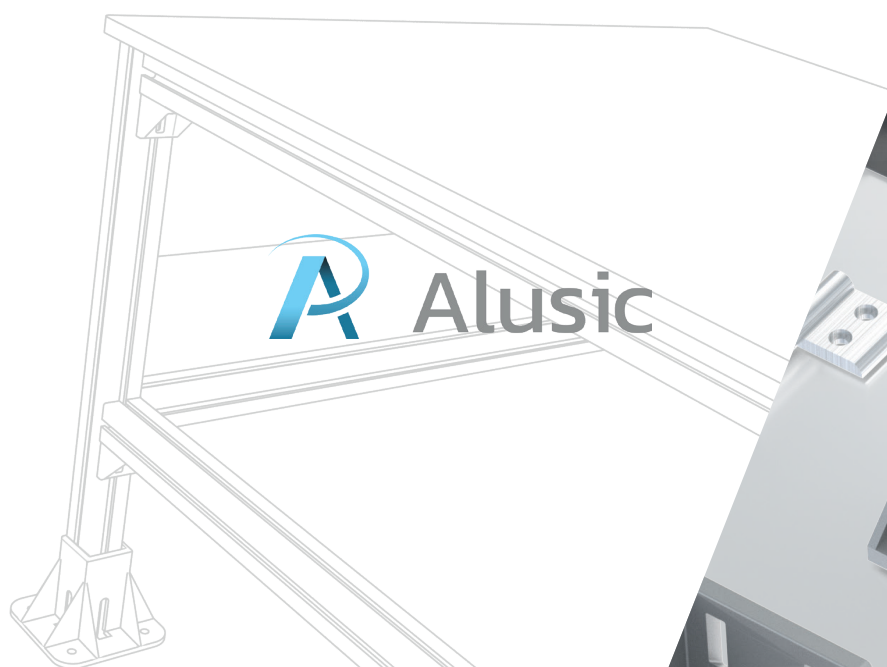

 Alusic

ALUSIC S.R.L.

VIA BOLOGNA, 10/A - 12084 - MONDOVI (CN) - ITALY

TEL.: (+39) 0174.55.29.49 - FAX: (+39) 0174.47.975

SKYPE: sic.com - MAIL: contact@alusic.com

www.alusic.com

copyright - 02/2024

